



Since 1987, the NORCAN Company has been distinguished by its high-quality modular structures formed by aluminium profiles connected by standard M8 screw fixings: a system that is flexible in use, simple to assemble, reliable, strong and economical.

50 models of closed or grooved profiles, and more than 600 accessories fully compatible with one another, provide solutions to the most diverse construction projects in every field.

The expertise of the 15 engineers in our Design Office, our high-technology manufacturing and assembly plants and our very extensive stock enable NORCAN to meet and genuinely exceed all our clients' demands.

Located in Alsace close to Strasbourg, NORCAN is the leading French manufacturer of profiles, and its network of consultants on applications and integration extends throughout Europe.

Our product quality and rigorous organisational procedures have enabled NORCAN to obtain ISO 9001 Version 2000 certification.

NORCAN



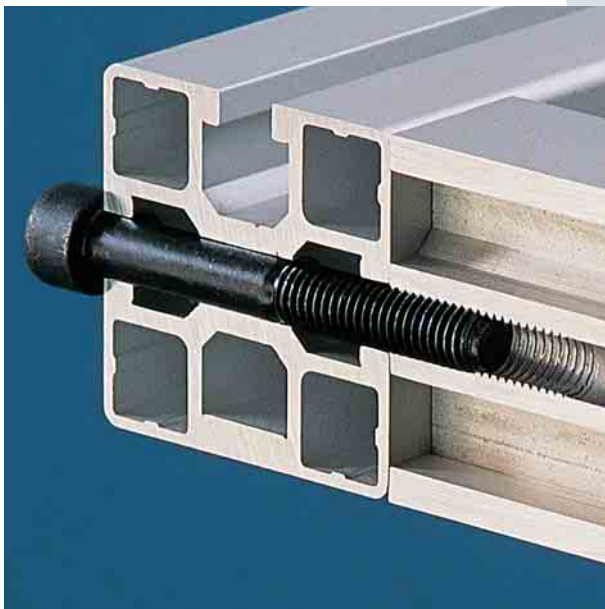
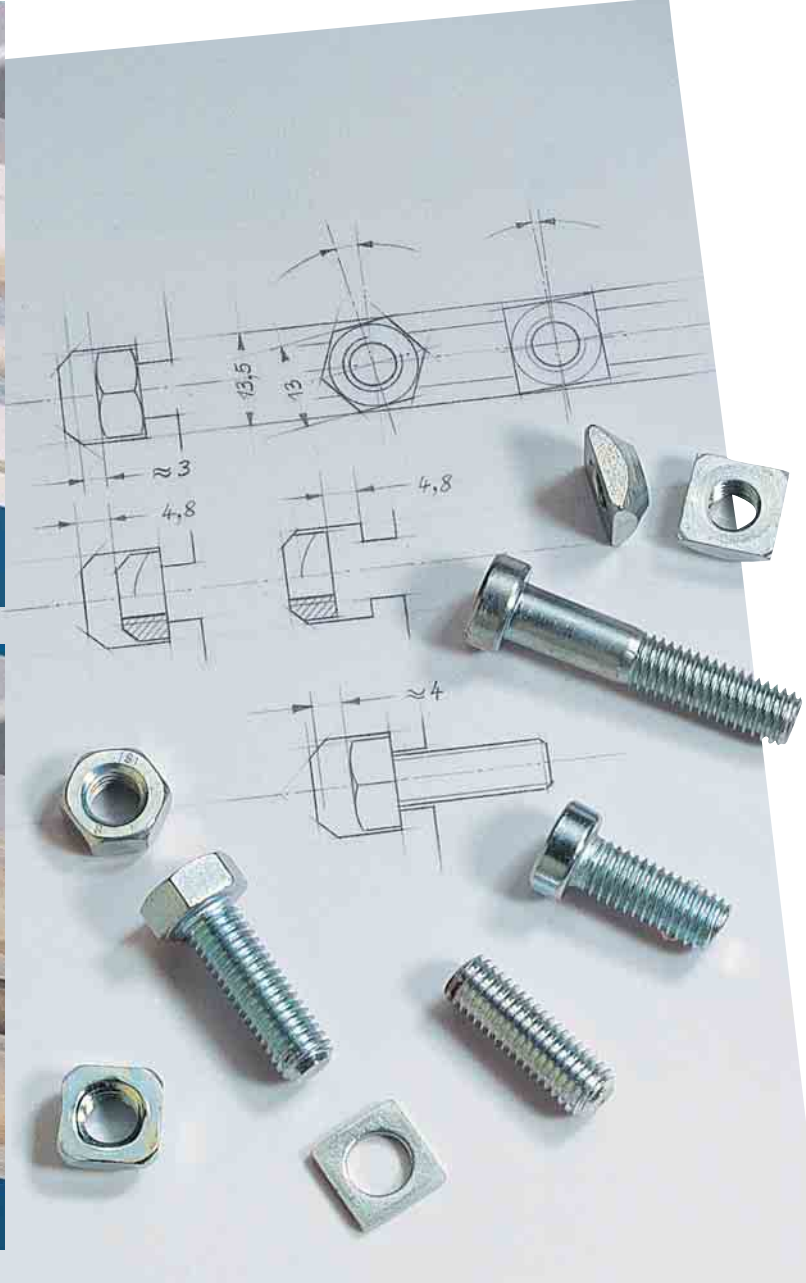

Built around standard M8 screws and nuts

Simply assembly

Rigid by design

Universal, modular construction and accessories

1. The grooves and slots of the NORCAN profiles for screws and nuts have straight parallel sides with minimal width (13,5 mm for 13 mm nuts and screwheads).

Due to this, the forces from the fixing elements are directed to the centre of the profile by the shortest path. The resulting assemblies are extremely rigid and resistant. (fig. 1 and 3).

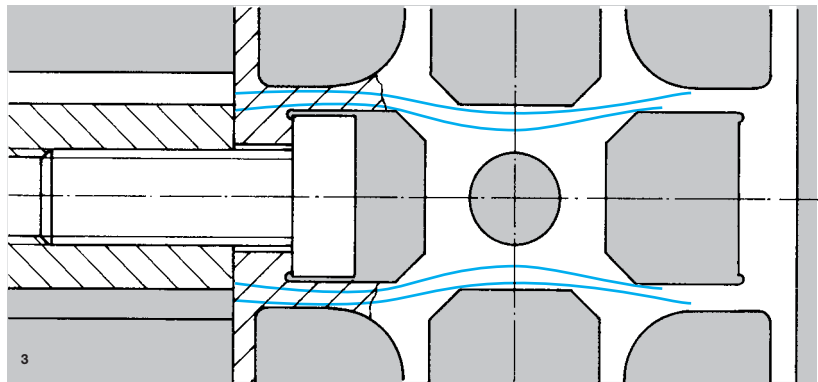
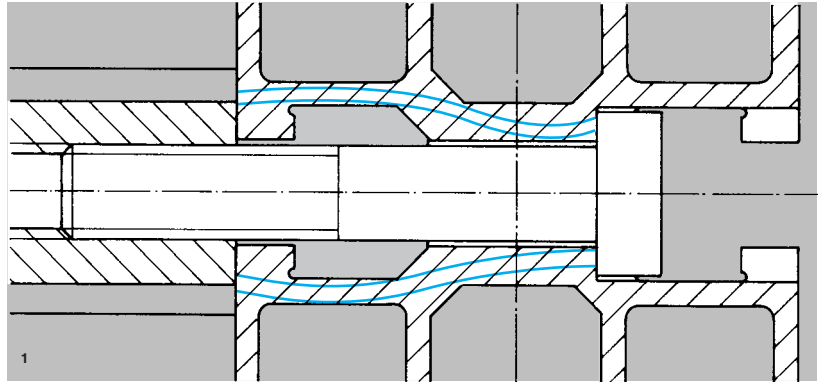

2. The NORCAN profiles have a deep slot allowing a large end play of the screwheads and nuts (figs. 4 and 5).

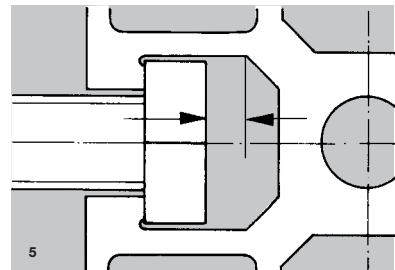
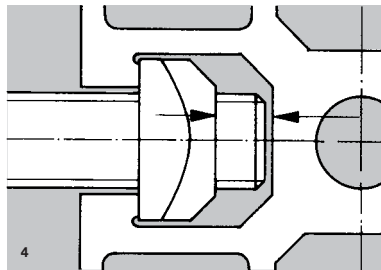

3. The M8 SC nuts with **standard M8 square nut dimensions** but with a chamfer can be tilted in the slot (nuts are also available in M6, M5, M4 and M3).

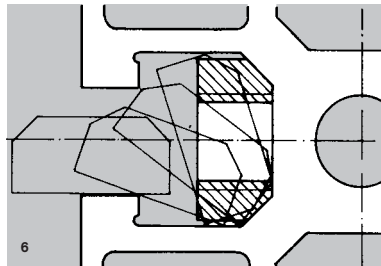

4. The assembly screws are fitted to the profile through countersinks to facilitate assembly and disassembly (fig. 8)

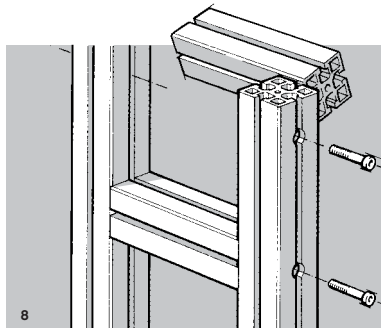

5. The M8 tapings in the profile ends are obtained by deformation with a fluteless tap providing increased mechanical resistance (fig. 9).

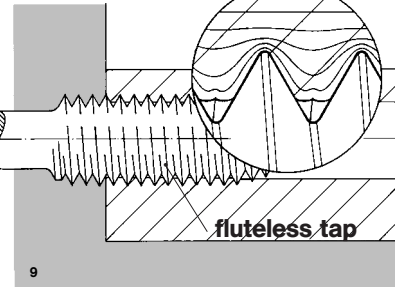

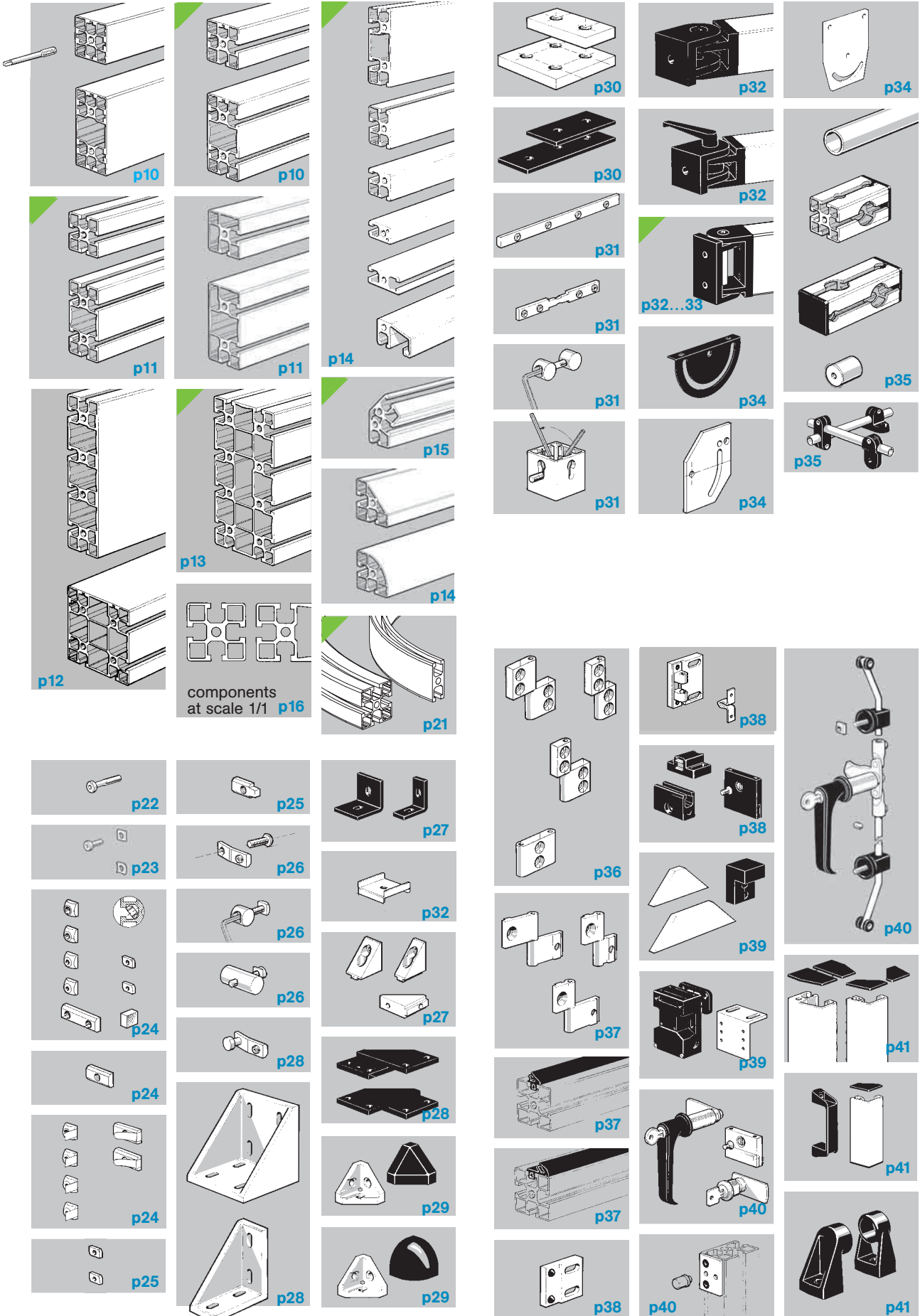

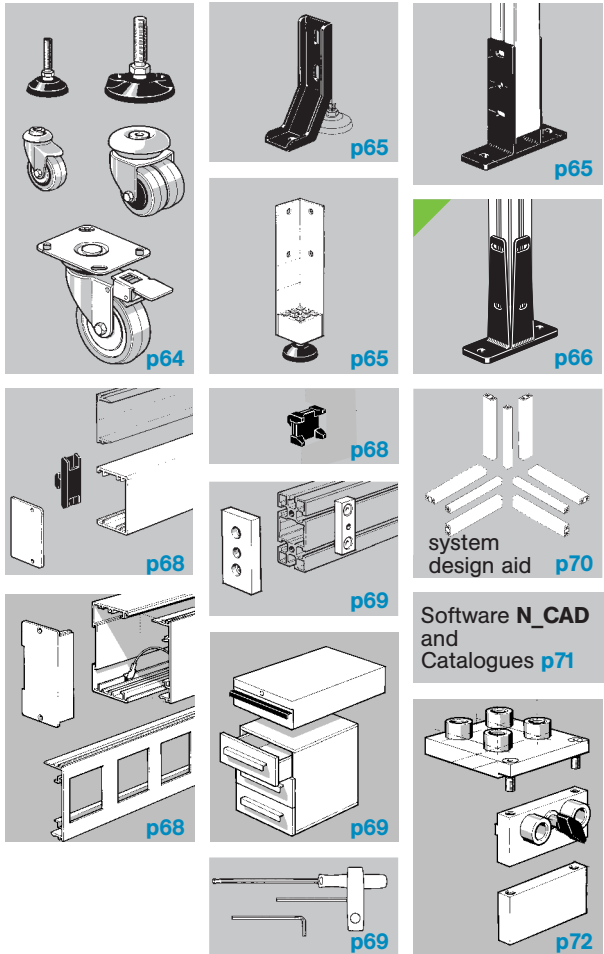
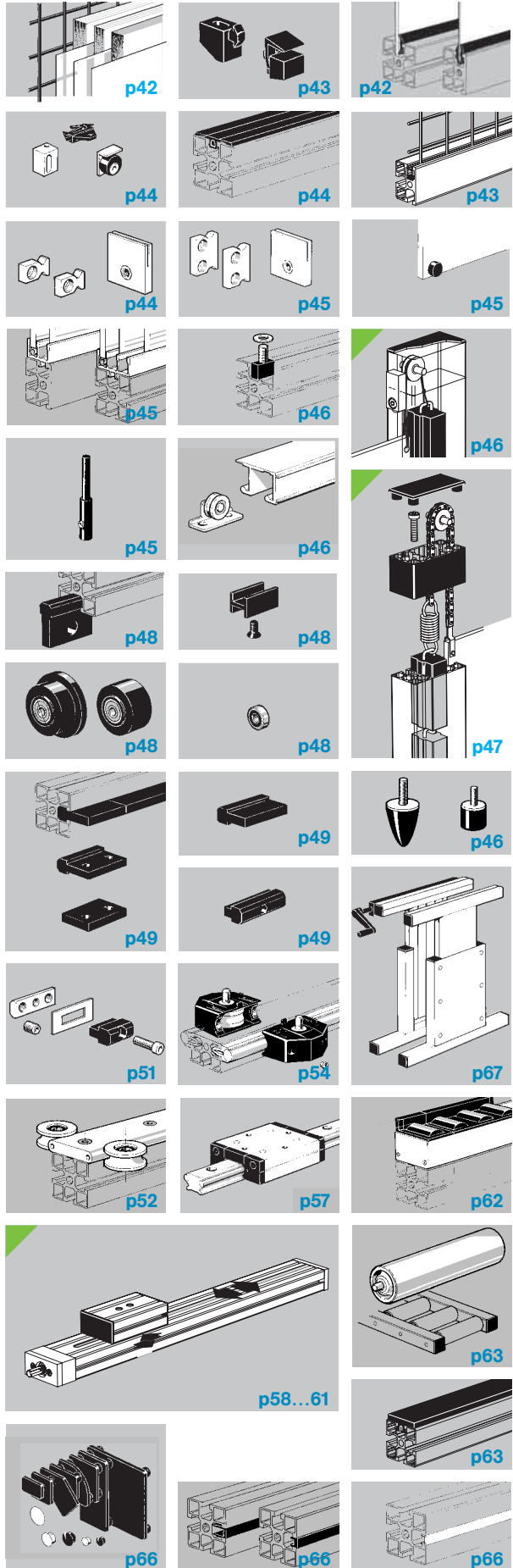

technical chapter

using M8 screws and bolt p73	loads and deflections p74	assembly applications p76
electrical continuity p78	fitting of glass and panels p79	

unities

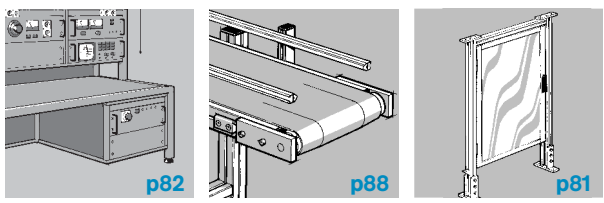

application examples p. 89...111
 system design aid and documents p. 112
 assembly instructions p114
alphabetic index p. 115

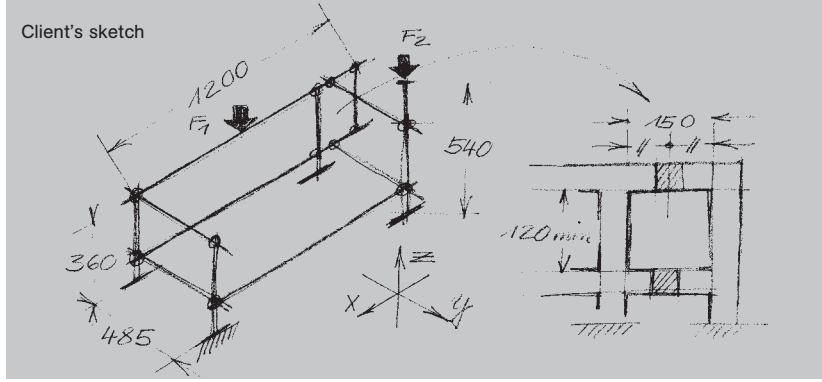

Project definition: Assistance and advice to define the project.

Design:

- Specification of machine frames, housings and other assemblies in NORCAN profiles using a specific software.
- Definition of special structures
- Definition of conveyors and linear guides.

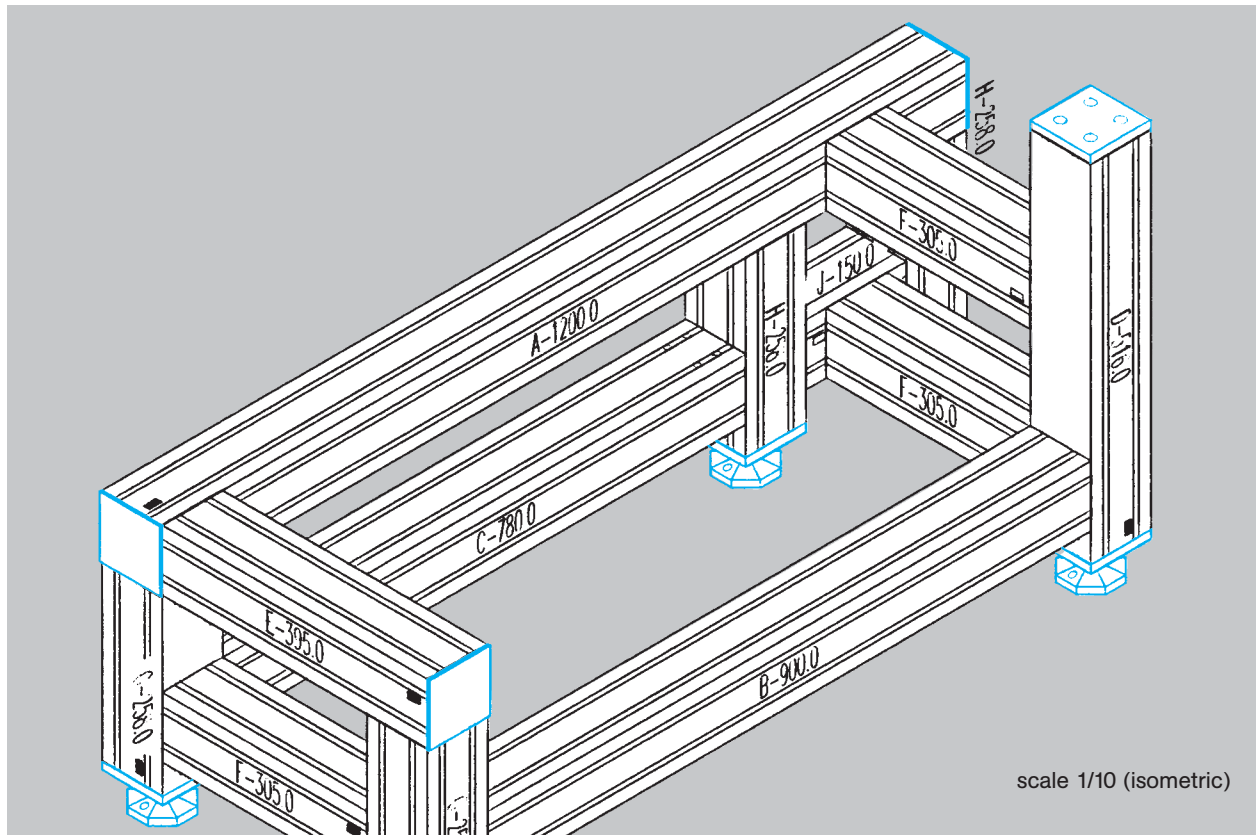

scale 1/10 (isometric)

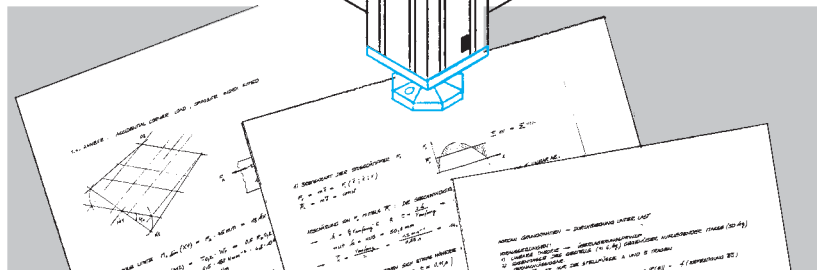

Calculations:

Calculations of deflection and allowable loads by applications of standard mechanical engineering methods.

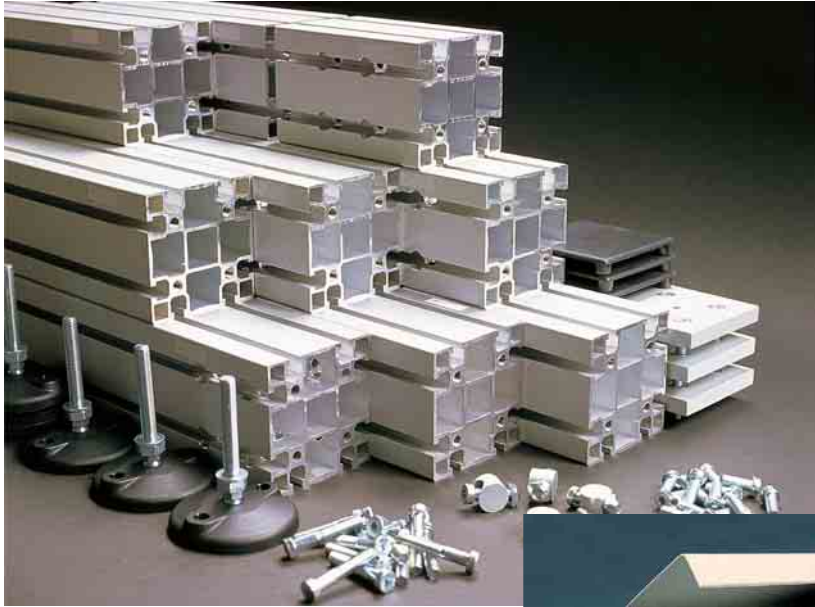
**Machining :**

- Quality cutting to length
- Milling
- Lathe Work
- Drilling and countersinking
- Bending
- Structural gluing of large section profiles.

Profiles machined according to this document or our drawings are individually referenced with labels indicating reference and assembly position allowing significant time saving during assembly.



Shipment of ready-to-assemble elements.

**Assembly :**

In our own workshops or at customer premises, we can carry out :

- Assembly of machine frames and housings
- Assembly and adjustment of conveyors
- Assembly of workstations.

Due the large time saving, we recommend the assembly of complex structures by NORCAN assembly personnel.



Shipment of an assembled structure.

Technical specifications of NORCAN profiles

Material	EN AW - 6060 (Al Mg Si 0,5)
Finish	anodised E 6 10 µm - other finishes on request
Elastic limit	R _p 0,2 = 195...210 Nmm ⁻² (N 0267 ≥ 165 Nmm ⁻²)
Shear stress	R _m = 240...260 Nmm ⁻² (N 0267 ≥ 220 Nmm ⁻²)
Resistance to fatigue (polished sample, alternate bending)	R _f ≈ 70 Nmm ⁻²
Modulus of elasticity	E = 7·10 ⁴ Nmm ⁻² ; G = 2,7·10 ⁴ Nmm ⁻²
Thermal expansion factor	24·10 ⁻⁶ K ⁻¹
Standard length	6 m

Electrical continuity: For structures which require a high degree of electrical continuity we can supply profiles treated with conductive ALODINE finish.

Every NORCAN profile is designed for use with standard M8 screws and bolts, the slot dimensions (width 13.5 mm) are such that every M8 screw or nut (hex and square-head screw, hex and square-head nut) can be slid along the slot while being prevented from rotating

The nuts NORCAN ..SC, ..LSC, ..RSC, ..RLSC can be tilted and inserted in to the slot.

M8 tappings in the profile ends are obtained by deformation, i.e. without chips; the central hole diameter is 7.4 mm. The tool, a **M8 fluteless tap** is available under the reference N 5510.

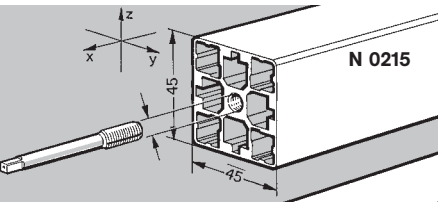
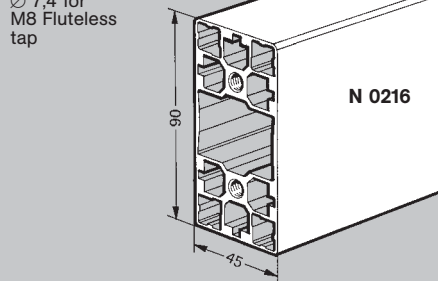
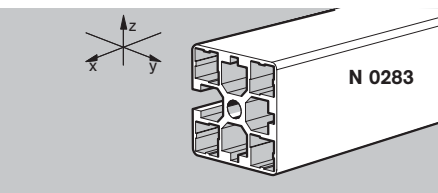
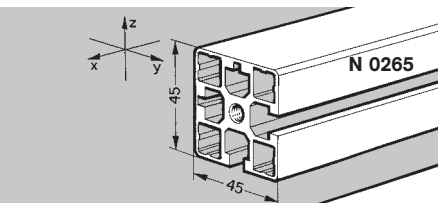
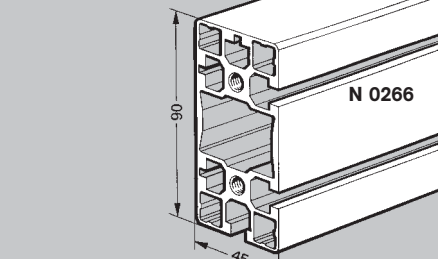
	Weight/linear [kg/m]	Area of cut [mm ²]	Moment of inertia ¹⁾		Polar moment of inertia ¹⁾ [mm ⁴]	¹⁾ Nominal value without machining in the yz plan
			I _y [mm ⁴]	I _z [mm ⁴]		
 <p>N 0215</p>	2,0	724	1,4 · 10 ⁵	1,4 · 10 ⁵	1,7 · 10 ⁵	<p>Profile 45x45 closed - N 0215: these profiles enable the building of modular structures in aluminium without visible slots, a common requirement for laboratory, food industry, pharmaceutical industry and clean-room use. The mechanical quality of the joints together with the high torsional rigidity of these structures is to be noted. Patent N° 91-14 579.</p>
 <p>N 0216</p>	3,4	1256	10 · 10 ⁵	2,6 · 10 ⁵	5,3 · 10 ⁵	<p>Profile 45x90 closed - N 0216: 45x90 version of the profile N 0215, above. Patent N° 91-14 579.</p>
 <p>N 0283</p>	1,8	682	1,4 · 10 ⁵	1,3 · 10 ⁵		<p>Profile 45x45 3 sides closed - N 0283: for structures and guarding.</p>
 <p>N 0265</p>	1,9	692	1,3 · 10 ⁵	1,3 · 10 ⁵	0,8 · 10 ⁵	<p>Profile 45x45 half closed - N 0265: for use in machine frames and housings with panels without visible slots.</p>
 <p>N 0266</p>	3,2	1176	9,8 · 10 ⁵	2,4 · 10 ⁵	3,1 · 10 ⁵	<p>Profile 45x90 half closed - N 0266: 45x90 version of the profile N 0265 above.</p>

	Weight/ linear [kg/m]	Area of cut [mm ²]	Moment of inertia ¹⁾		Polar moment of inertia ¹⁾ [mm ⁴]	¹⁾ Nominal value without machining in the yz plan
			I _y [mm ⁴]	I _z [mm ⁴]		
<p>N 0275</p>	1,4	522	1,0 · 10 ⁵	1,0 · 10 ⁵	0,6 · 10 ⁵	<p>Profile 45x45 half closed light - N 0275 : half closed profiles for guarding and light structures. Important! Only the slotted sides of the profiles are used for assembly – see p. 73...75.</p>
<p>N 0276</p>	2,4	900	7,5 · 10 ⁵	1,9 · 10 ⁵	1,8 · 10 ⁵	<p>Profile 45x90 half closed light - N 0276 : 45x90 version of the profile N 0275 above.</p>
<p>N 0284</p>	1,8	656	1,2 · 10 ⁵	1,4 · 10 ⁵		<p>Profile 45x45 2 opposed sides closed - N 0284 : for structures and guarding.</p>
<p>N 0285</p>	1,7	631	1,2 · 10 ⁵	1,3 · 10 ⁵		<p>Profile 45x45 1 side closed - N 0285 : for structures and guarding.</p>
<p>N 0286</p>	2,9	1084	9,2 · 10 ⁵	2,3 · 10 ⁵		<p>Profile 45x90 1 side closed - N 0286 : 45x90 version of the profile N0285 above.</p>
<p>N 0165</p>	1,7	611	1,1 · 10 ⁵	1,1 · 10 ⁵	0,25 · 10 ⁵	<p>Profile 45x45 - N 0165 : profiles for use on machine frames, tables, supports and large housings where 4 profile slots are necessary.</p>
<p>N 0166</p>	2,7	990	8,3 · 10 ⁵	2,1 · 10 ⁵	1,3 · 10 ⁵	<p>Profile 45x45 - N 0166 : 45 x 90 version of the profile N0165 above.</p>

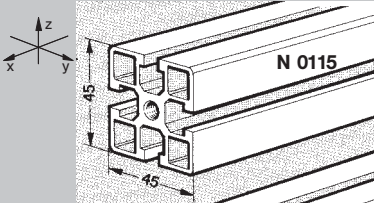
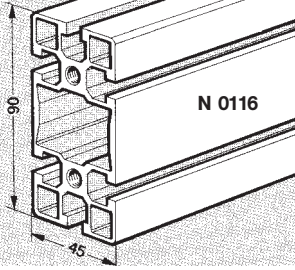
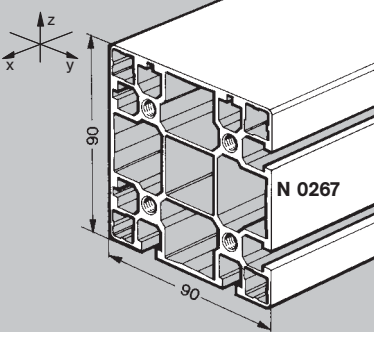
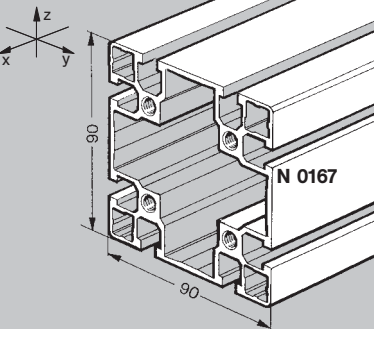
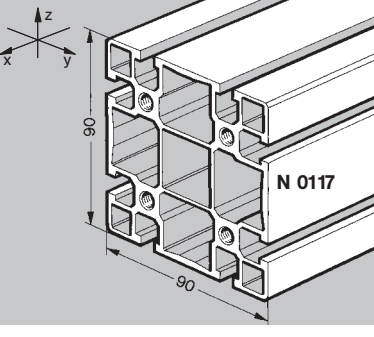
	Weight/ linear [kg/m]	Area of cut [mm ²]	Moment of inertia ¹⁾		Polar moment of inertia ¹⁾ [mm ⁴]	¹⁾ Nominal value without machining in the yz plan
			I _y [mm ⁴]	I _z [mm ⁴]		
 <p>N 0115</p>	1,9	698	1,3 · 10 ⁵	1,3 · 10 ⁵	0,3 · 10 ⁵	Profile 45x45 heavy - N 0115 : heavier version of the N 0165 profile.
 <p>N 0116</p>	3,3	1217	9,8 · 10 ⁵	2,6 · 10 ⁵	1,7 · 10 ⁵	Profile 45x90 heavy - N 0116 : heavier version of the N 0166 profile.
 <p>N 0267</p>	5,5	2027	16 · 10 ⁵	16 · 10 ⁵	12 · 10 ⁵	Profile 90x90 half closed - N 0267
 <p>N 0167</p>	4,2	1548	14 · 10 ⁵	14 · 10 ⁵		Profile 90x90 - N 0167
 <p>N 0117</p>	5,9	2154	18 · 10 ⁵	18 · 10 ⁵	8,5 · 10 ⁵	Profile 90x90 heavy - N 0117 : heavier version of the N 0167 profile.

	Weight/ linear [kg/m]	Area of cut [mm ²] ¹⁾	Moment of inertia ¹⁾		Polar moment of inertia ¹⁾ [mm ⁴]	1) Nominal value without machining in the yz plan
			I _y [mm ⁴]	I _z [mm ⁴]		

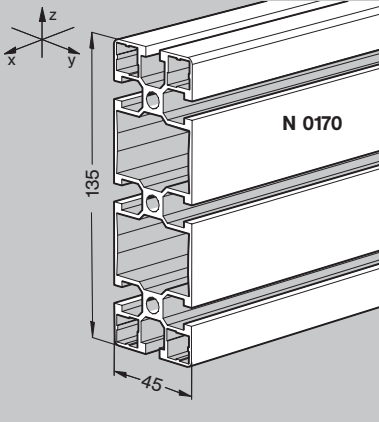

N 0170	3,7	1388	26 · 10 ⁵	3,1 · 10 ⁵		Profile 45 x 135 - N 0170
---------------	-----	------	----------------------	-----------------------	--	----------------------------------

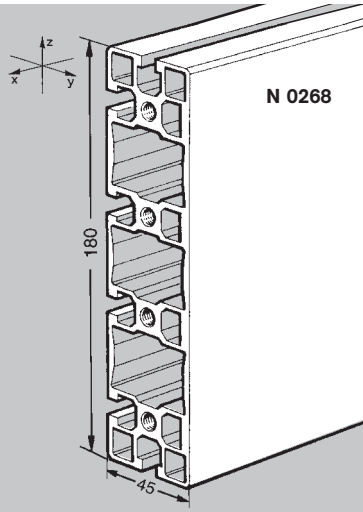

N 0268	6,5	2408	73 · 10 ⁵	5,5 · 10 ⁵	7,7 · 10 ⁵	Profile 45 x 180 1 side closed heavy - N 0268
---------------	-----	------	----------------------	-----------------------	-----------------------	--

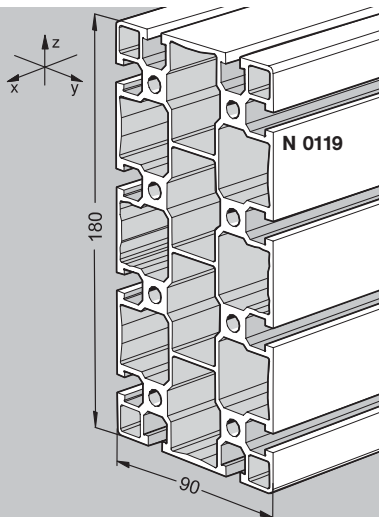

N 0119	10,6	3937	124 · 10 ⁵	33 · 10 ⁵		Profile 90 x 180 heavy - N 0119 : large section profile to meet high load and stiffness specifications.
---------------	------	------	-----------------------	----------------------	--	--

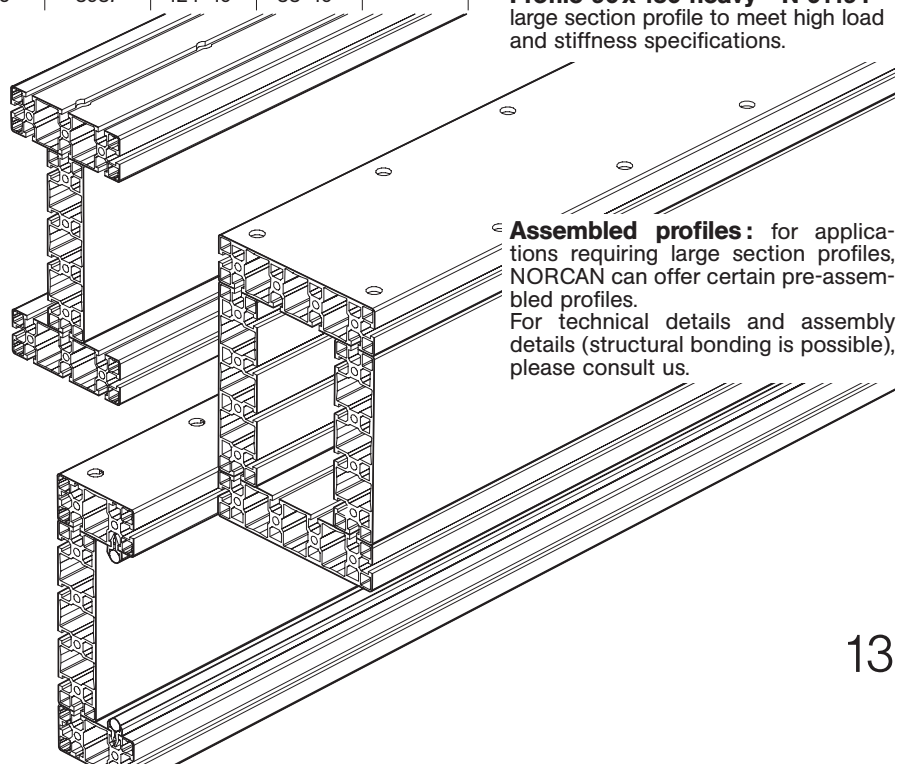

€ **Assembled profiles:** for applications requiring large section profiles, NORCAN can offer certain pre-assembled profiles. For technical details and assembly details (structural bonding is possible), please consult us.

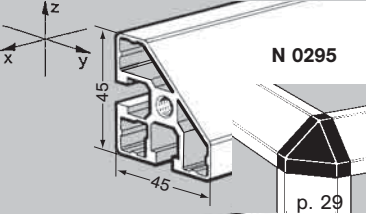
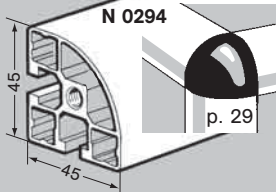
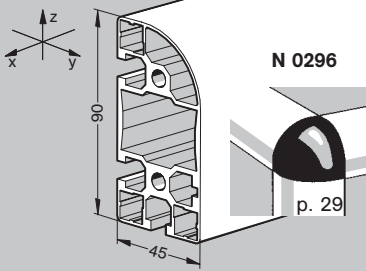
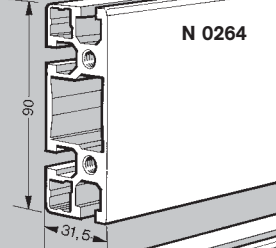
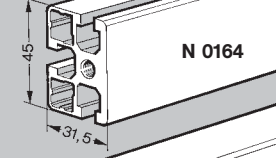
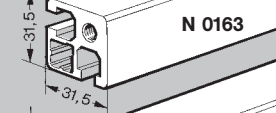
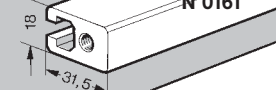
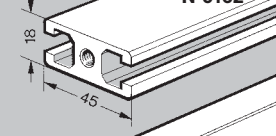
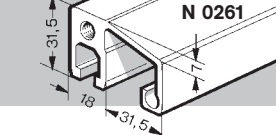
	Weight/ linear [kg/m]	Area of cut [mm ²] ¹⁾	Moment of inertia ¹⁾		Polar moment of inertia ¹⁾ [mm ⁴]	¹⁾ Nominal value without machining in the yz plan
			I _y [mm ⁴]	I _z [mm ⁴]		
 <p>N 0295</p>	1,2	459	6,9 · 10 ⁴	6,9 · 10 ⁴		Profile 45x45 triangle - N 0295 : for guarding, office and workshop furniture. Assembly see p. 29.
 <p>N 0294</p>	1,5	502	9,3 · 10 ⁴	9,3 · 10 ⁴		Profile 45x45 1/4 round - N 0294 : for guarding, office and workshop furniture. Assembly see p. 29.
 <p>N 0296</p>	2,9	1071	75 · 10 ⁴	22 · 10 ⁴		Profile 45x90 1/4 round - N 0296 : 45x90 version of the profile N 0294 above.
 <p>N 0264</p>	2,3	855	66 · 10 ⁴	10 · 10 ⁴		Profile 31,5x 90 - N 0264 New housing profiles: for use for protection housings, small frames and laboratory equipment. Used with closed and half closed profiles, it is possible to make attractive structures without visible slots.
 <p>N 0164</p>	1,3	490	8,2 · 10 ⁴	5,3 · 10 ⁴	2,1 · 10 ⁴	Profile 31,5x 45 - N 0164
 <p>N 0163</p>	1,1	409	4,0 · 10 ⁴	4,0 · 10 ⁴	1,3 · 10 ⁴	Profile 31,5x 31,5 - N 0163
 <p>N 0161</p>	0,9	327	2,7 · 10 ⁴	1,2 · 10 ⁴	1,2 · 10 ⁴	Profile 18x 31,5 - N 0161
 <p>N 0162</p>	1,0	379	5,3 · 10 ⁴	1,7 · 10 ⁴	0,9 · 10 ⁴	Profile 18x 45 - N 0162
 <p>N 0261</p>	1,2	439	4,1 · 10 ⁴	11 · 10 ⁴		Profile 18x 31,5 with handle - N 0261 : avoids the need for additional handles and improves rigidity and ergonomic properties of doors. End plates see p. 41.

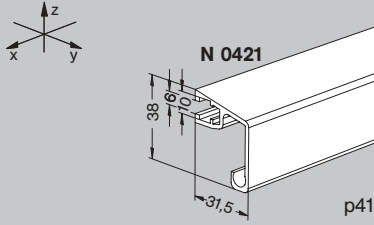
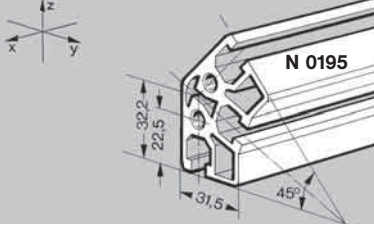
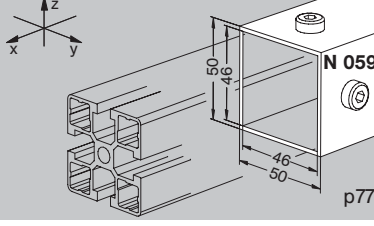
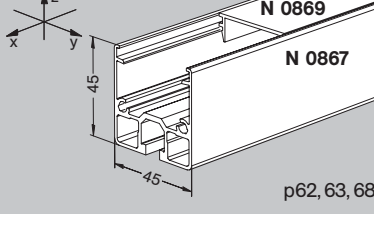
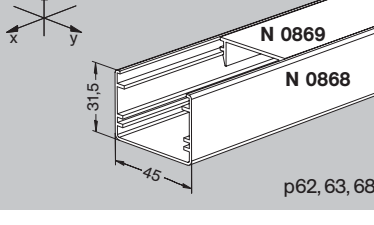
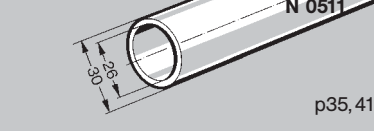
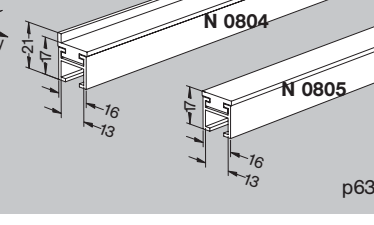
	Weight/ linear [kg/m]	Area of cut [mm ²] ¹⁾	Moment of inertia ¹⁾		Polar moment of inertia ¹⁾ [mm ⁴]	¹⁾ Nominal value without machining in the yz plan
			I _y [mm ⁴]	I _z [mm ⁴]		
 <p>N 0421 p41</p>	0,5	205	2,2 · 10 ⁴	2,7 · 10 ⁴		Profile for handle - N 0421 : for long handles, cut to suit. Ideal for stiffening panels of 5 or 8 mm in sliding doors see p. 41.
 <p>N 0195 p77</p>	2,0	731	17 · 10 ⁴	8 · 10 ⁴	4,3 · 10 ⁴	Profile 31,5/45° - N 0195 : to assemble all NORCAN profiles at an angle of 135° - see p. 77.
 <p>N 0599 p77</p>	1,0	384	15 · 10 ⁴	15 · 10 ⁴	30 · 10 ⁴	50/46 square tubing - N 0599 : for telescopic mountings with 45 x 45 profiles. The fixing is made with 2 pairs of M8 x 16 screws (N3133) and M8 SC or M8LSC nuts at 90°. Important! Do not position the screws across the axis of the profile – danger of deformation. See p. 77.
 <p>N 0869 N 0867 p62, 63, 68</p>	1,0	381	5,4 · 10 ⁴	11 · 10 ⁴		U section profile 45x45 - N 0867 : to provide a neat solution for routing cables (p.68) and for conveyor rails with roller units (p. 62, 63). Snap in cover for U section profile - N0869
 <p>N 0869 N 0868 p62, 63, 68</p>	0,5	170	1,8 · 10 ⁴	5,9 · 10 ⁴		U section profile 31,5x45 - N 0868 : to provide a neat solution for routing cables (p. 68) and for light conveyor rails with roller units (p. 62, 63).
 <p>N 0511 p35, 41</p>	0,5	175	1,7 · 10 ⁴	1,7 · 10 ⁴	3,5 · 10 ⁴	Tubing ø 30 x 2 - N 0511 : multipurpose fixing and spacing element (p. 35 and 41).
 <p>N 0804 N 0805 p63</p>	0,2	77	0,14 · 10 ⁴	0,3 · 10 ⁴		Lateral guide - N 0805 Slide rail - N 0804 : very light profiles for guides and light supports (p. 63).

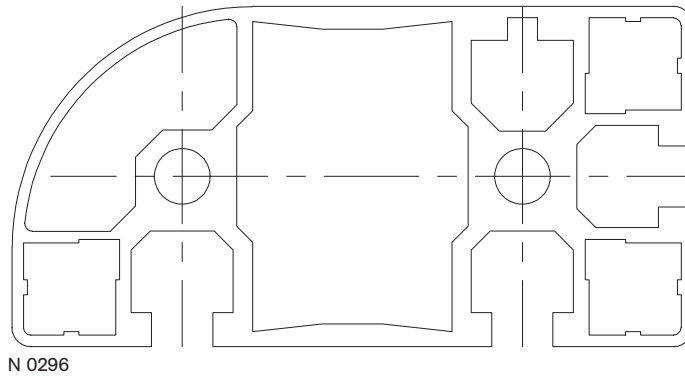
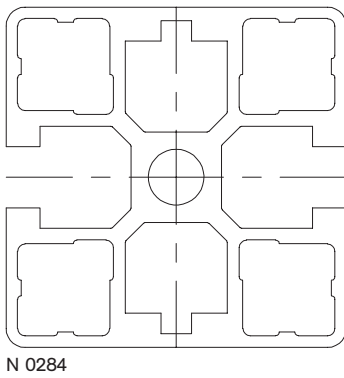
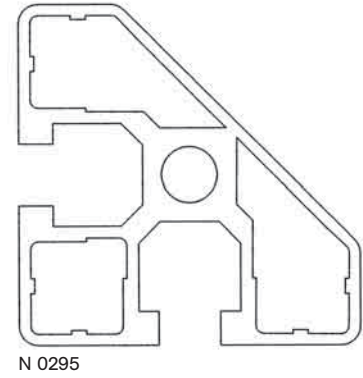
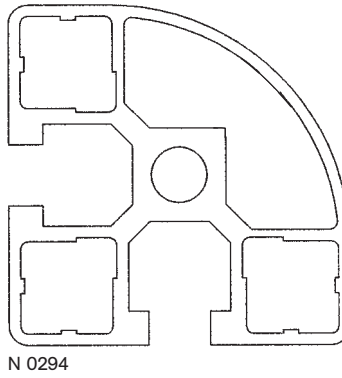
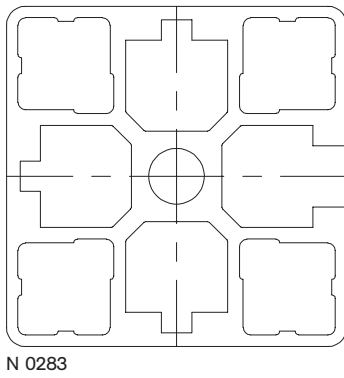
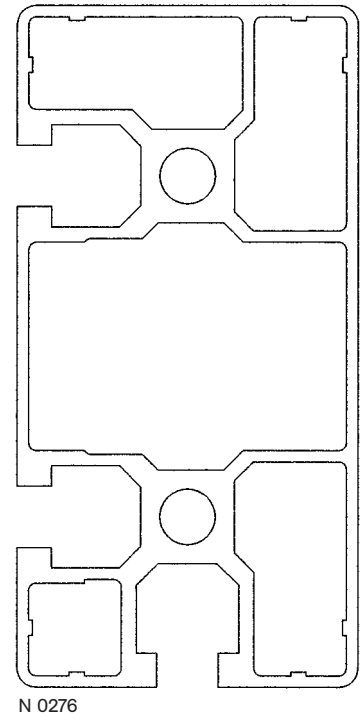
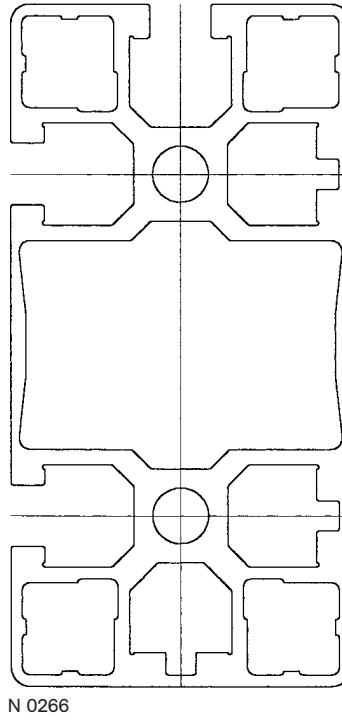
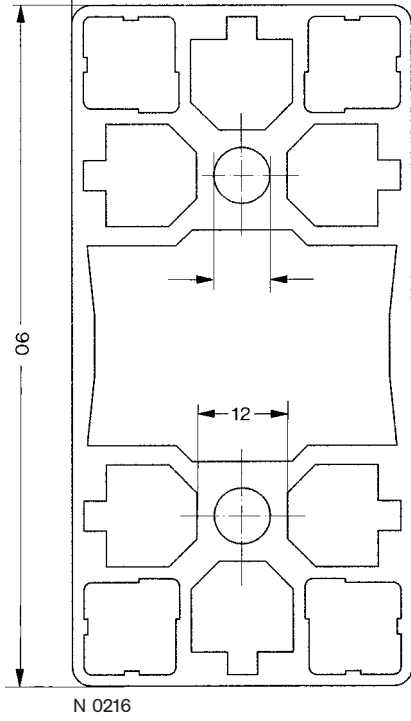
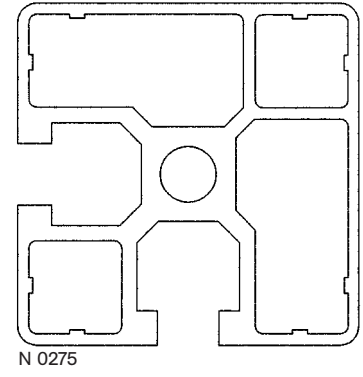
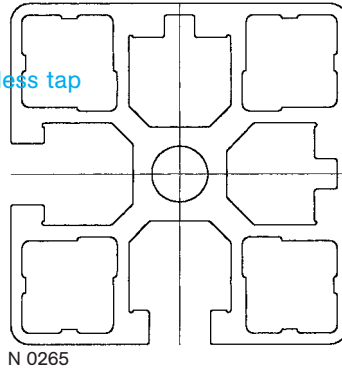
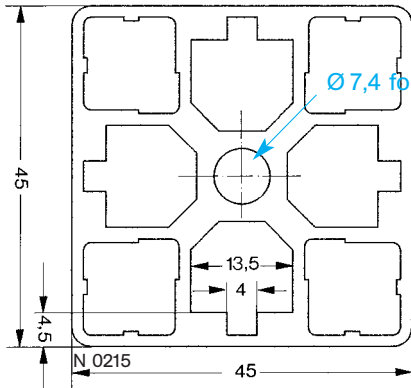

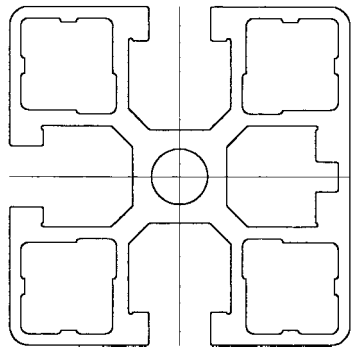

N 0285

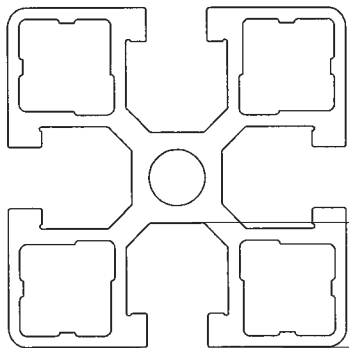

N 0165

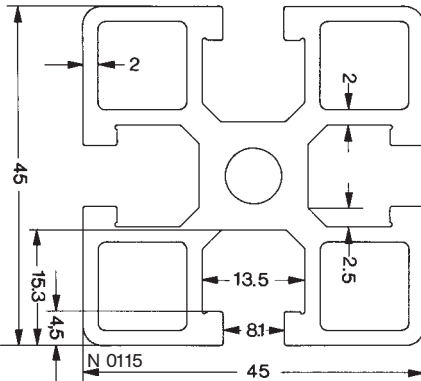

N 0115

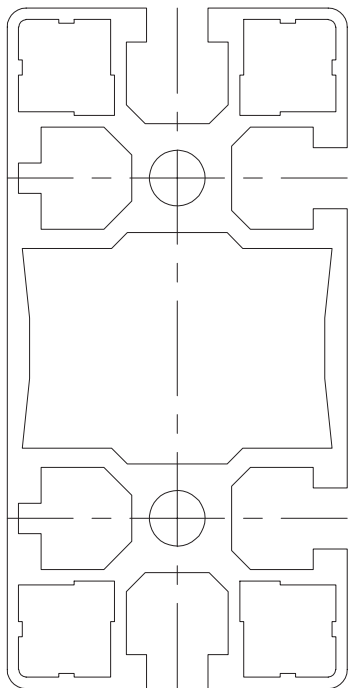

N 0286

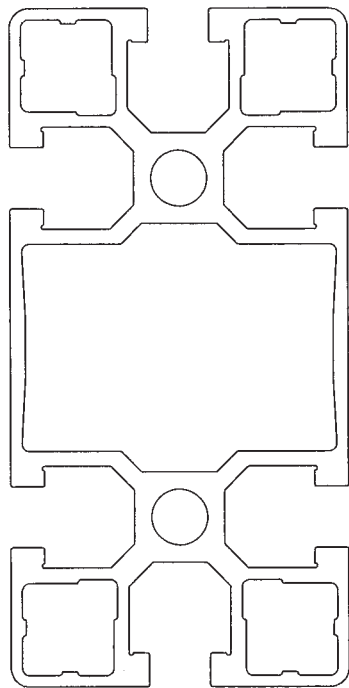

N 0166

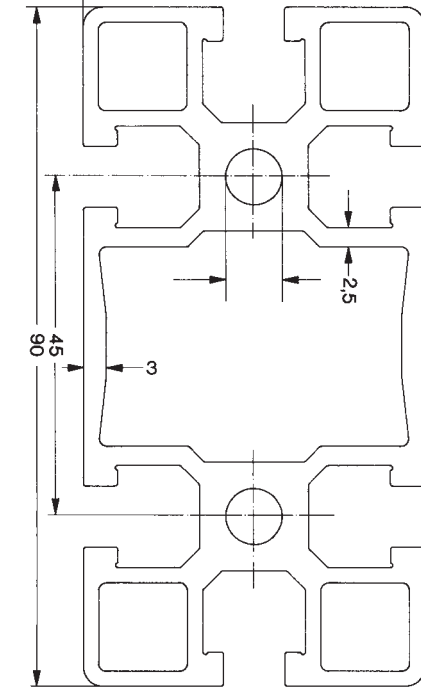

N 0116

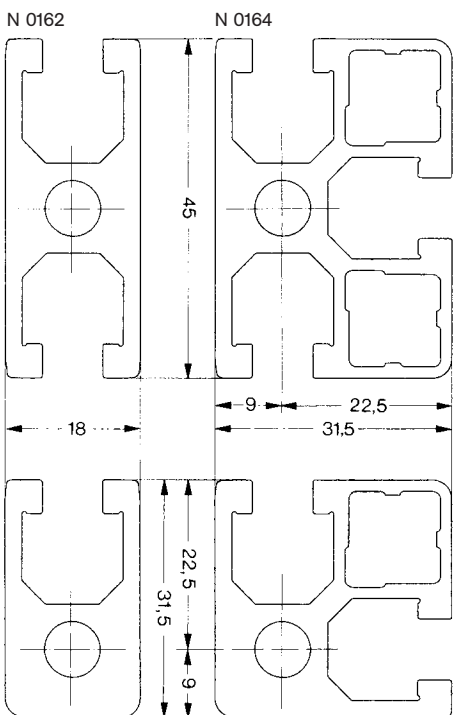

N 0161

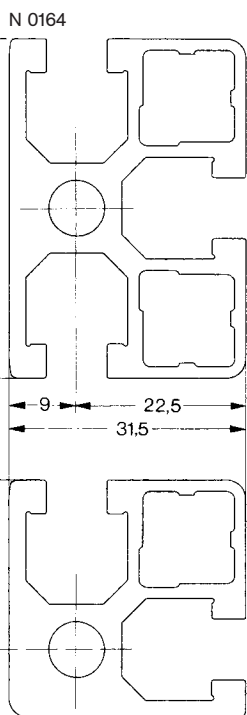

N 0163

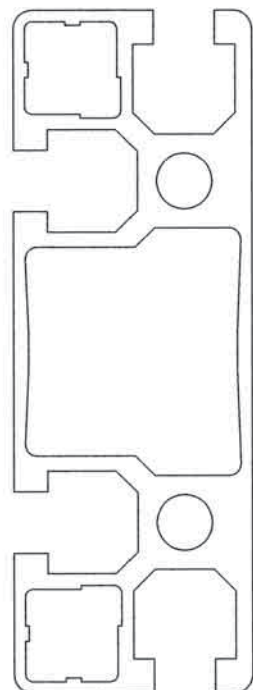

N 0264

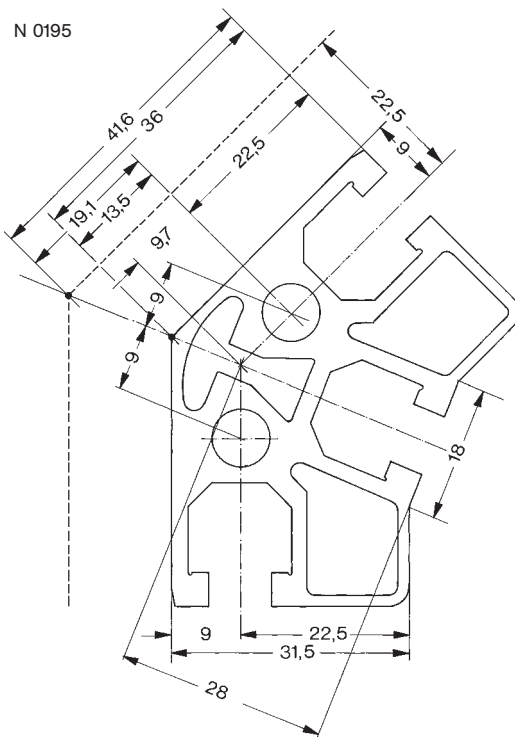

N 0195

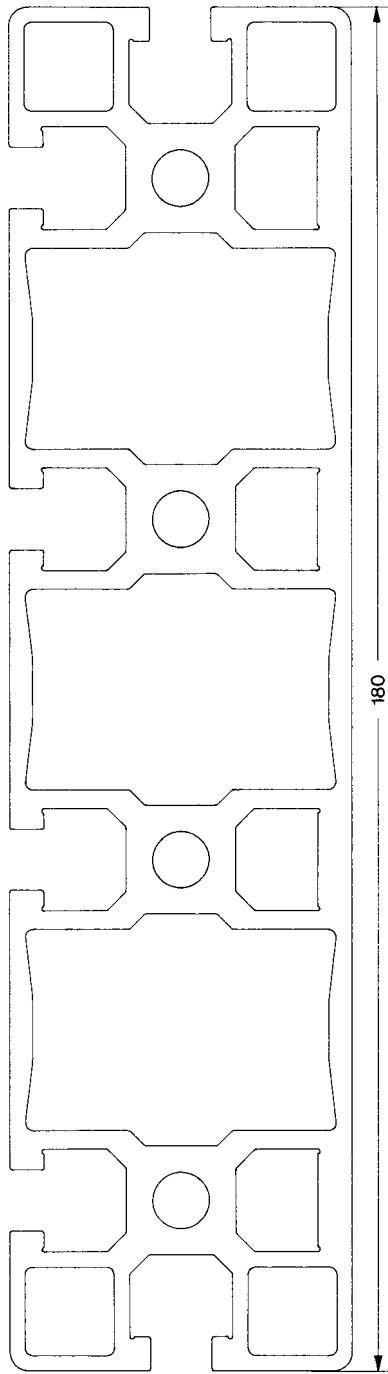

N 0268

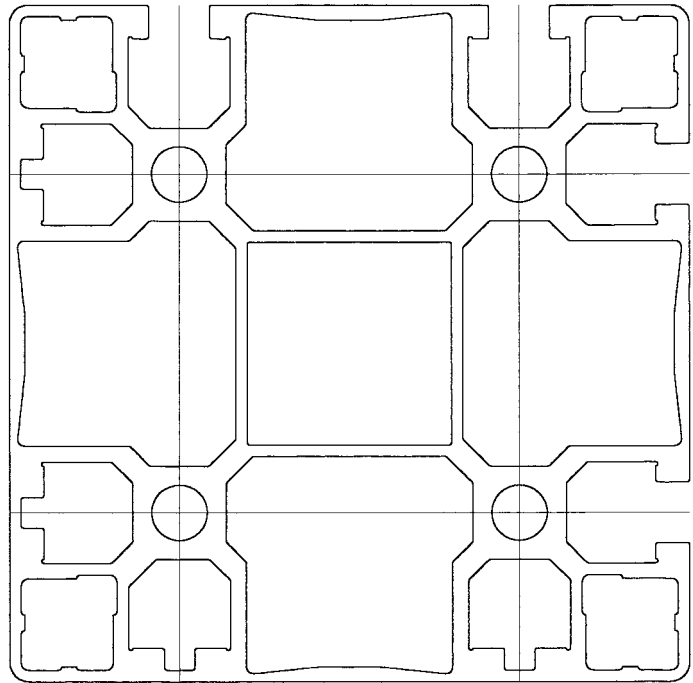

N 0267

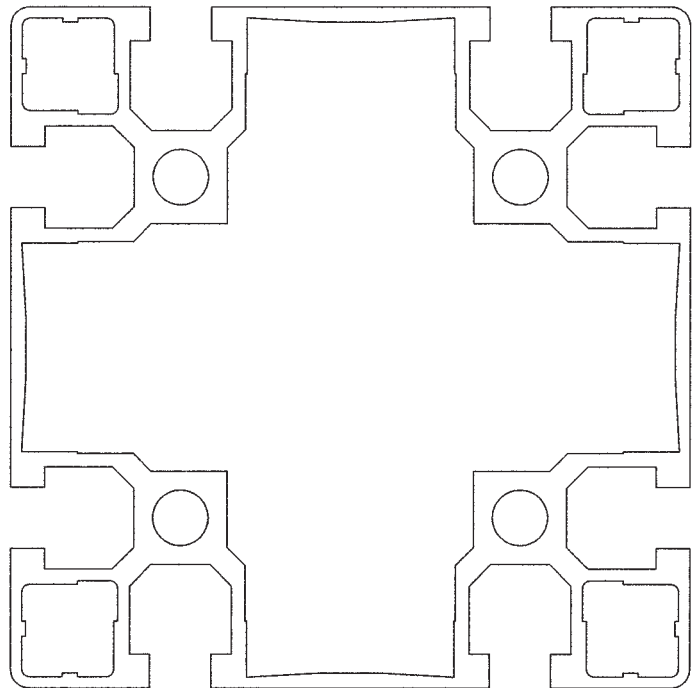

N 0167

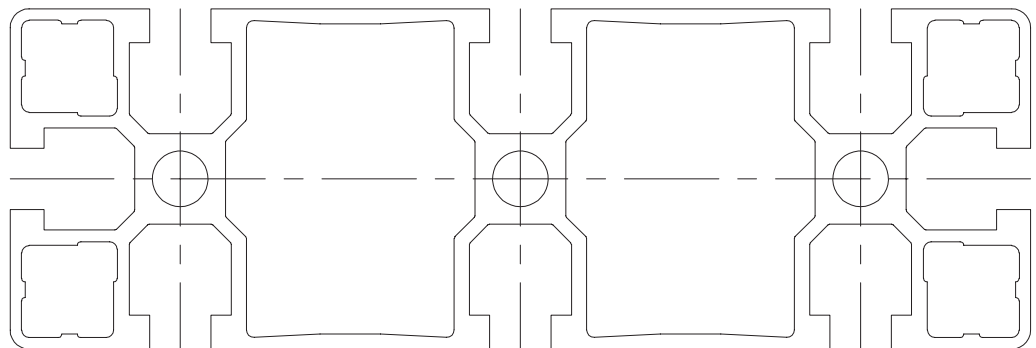

N 0170

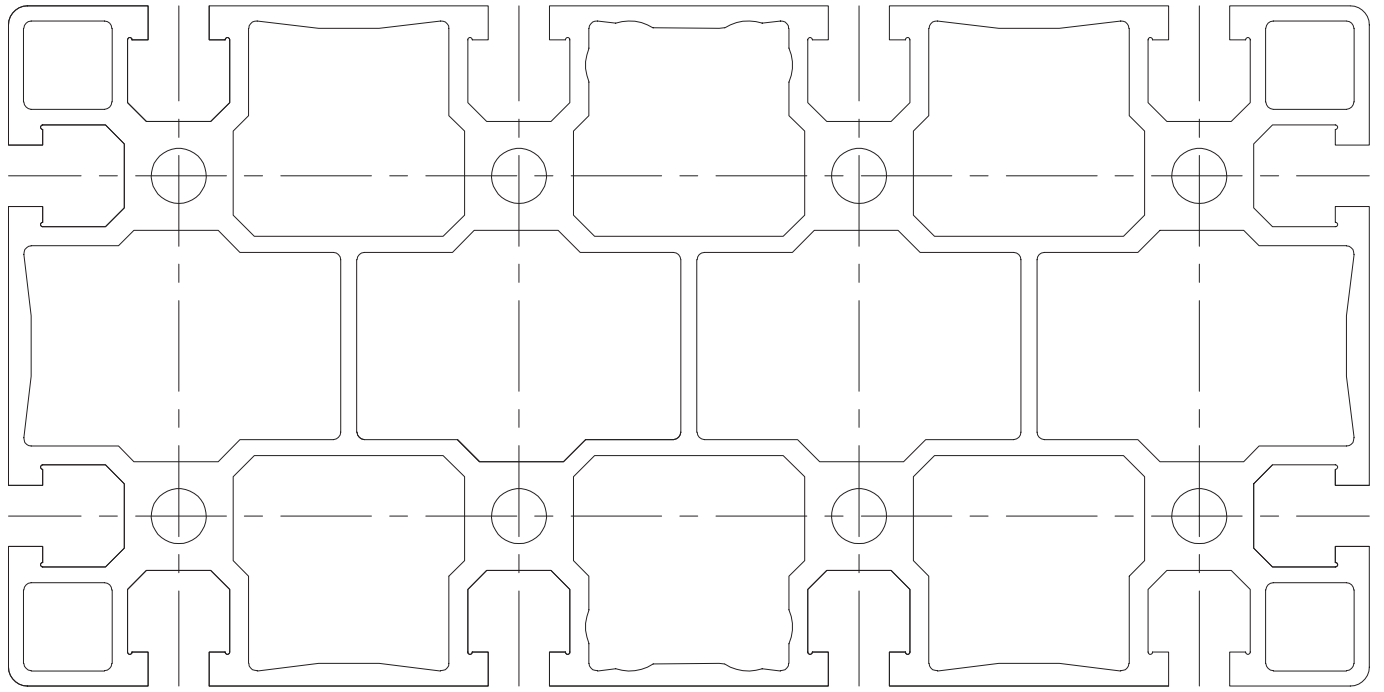

N 0119

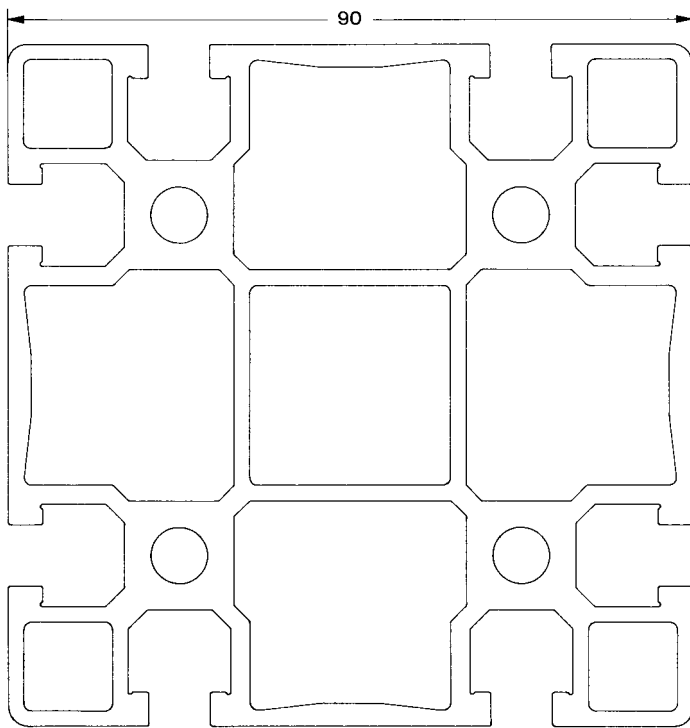

N 0117

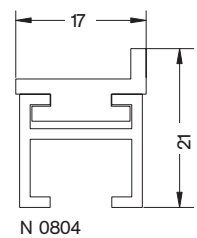
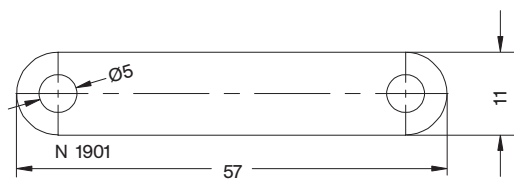
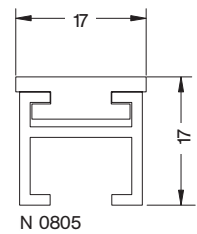
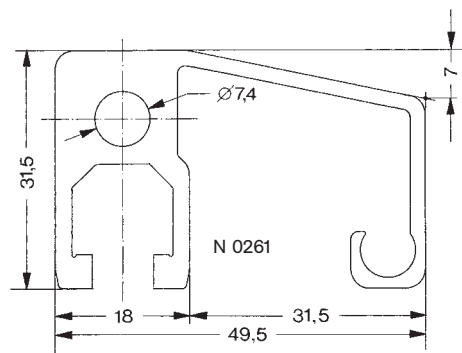
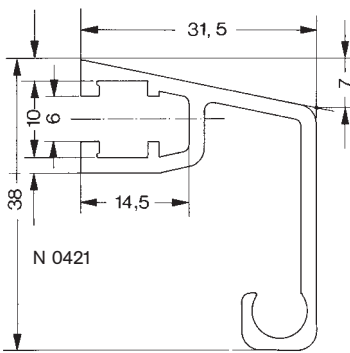
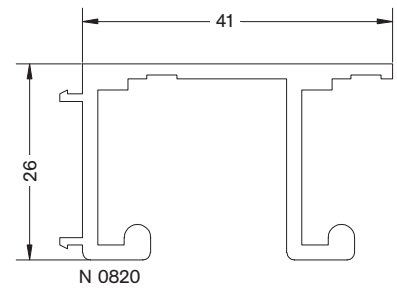
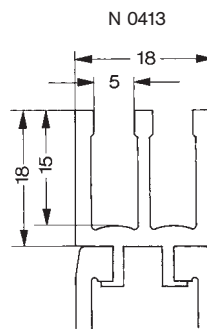
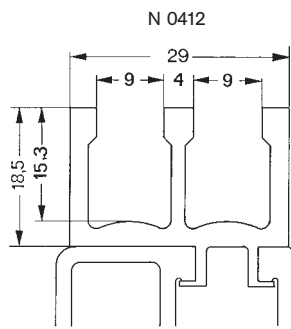
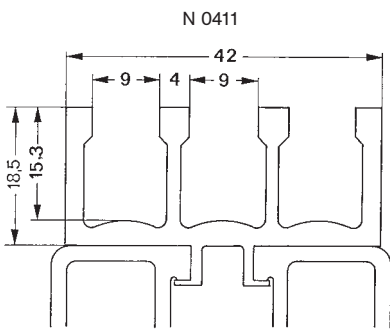
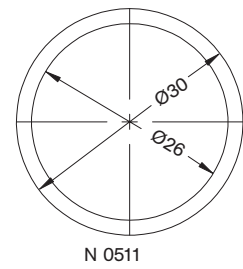
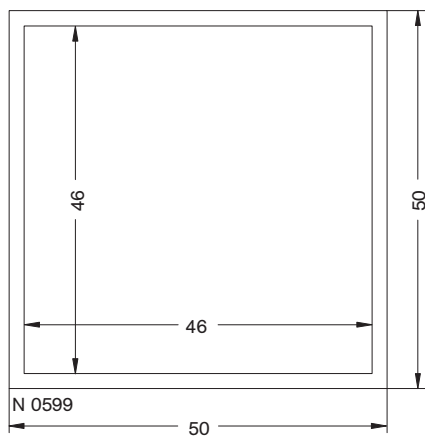
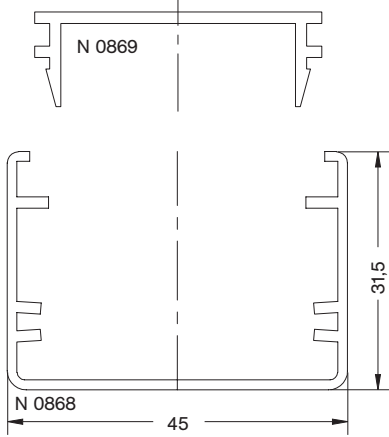
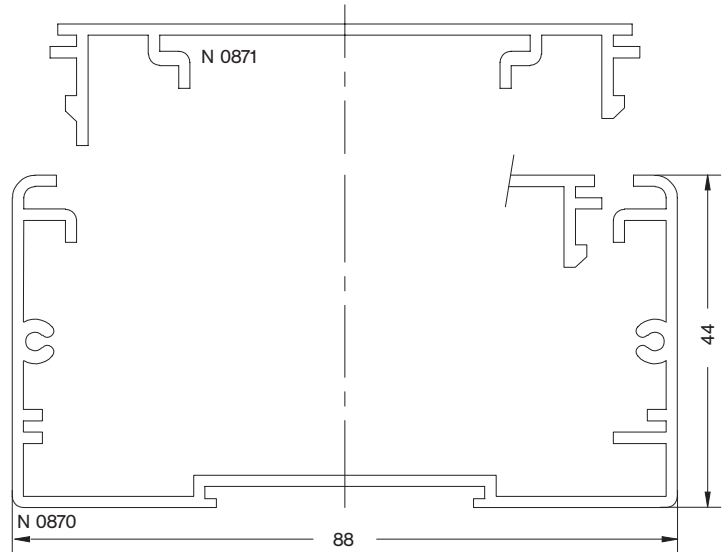
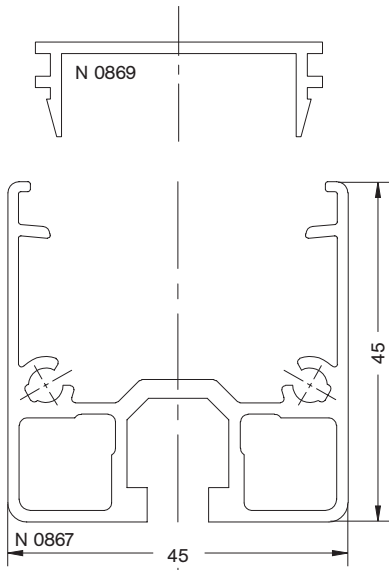

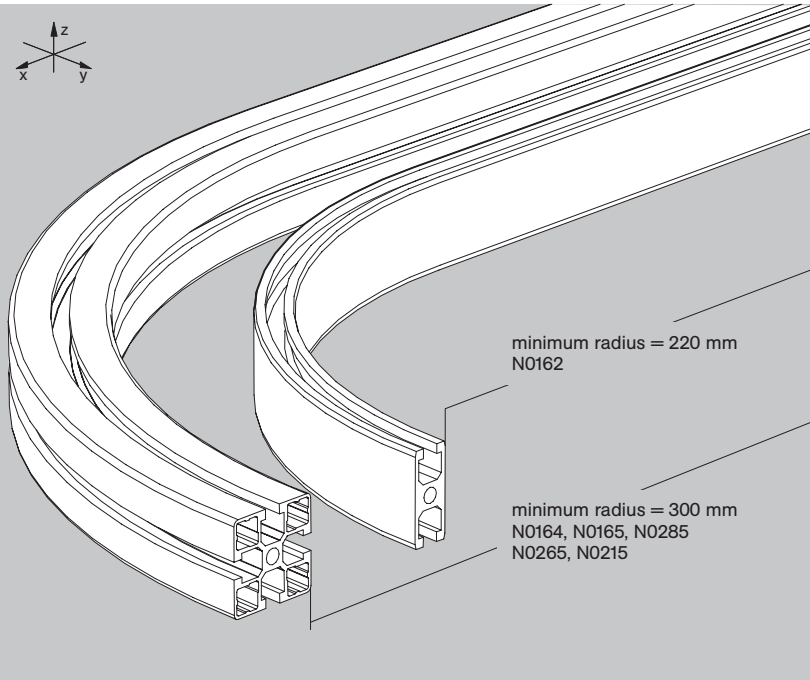

Most NORCAN profiles can be curved. The drawing shows the possibilities for some NORCAN construction profiles.

The profile section is only deformed a small amount and can be anodized, cut and milled afterwards.

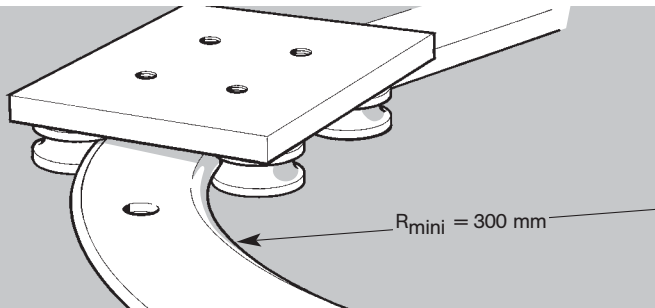

Curved rails for guidances: the rails for the linear guidance system NAP57 may be curved to a minimum radius of 300mm.

The carriages must be individually adjusted to every rail – it is necessary to contact our technical department before using these rails.



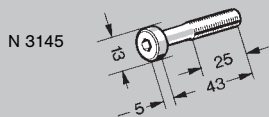

Low-Head Screw M8 x 43 - N 3145

Grade 8.8 zinc coated - 5 mm key

M8 x 45 stainless steel - N 3545

Low-Head Screw M8 x 43 Nyloc - N 3195

Tightening torque, maximum load, deflection under load, pages 73 to 75.

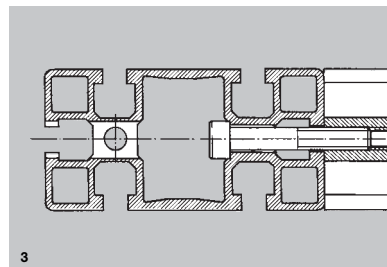
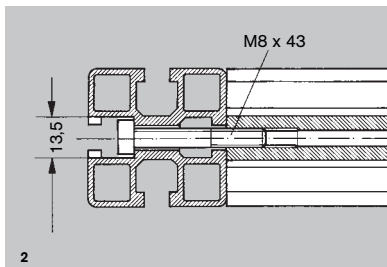
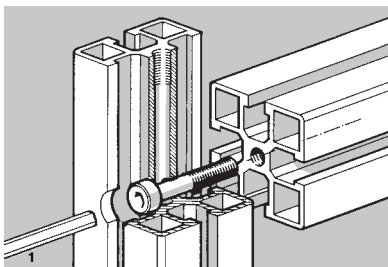

Standard assembly for NORCAN profiles

- high static loads
- excellent resistance to dynamic loads
- very good stiffness

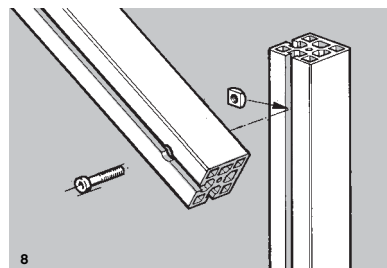
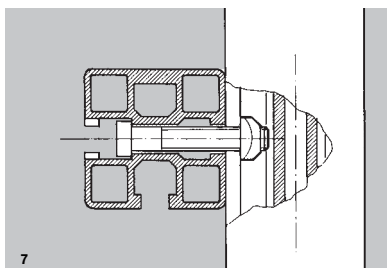
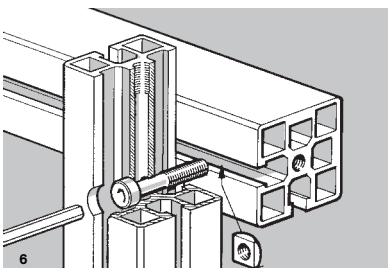
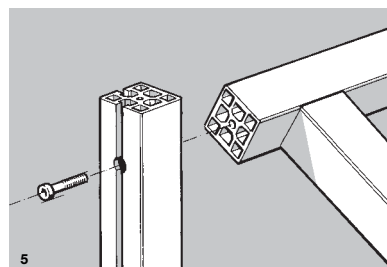
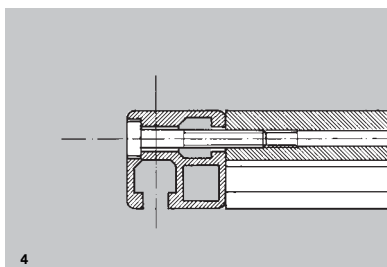

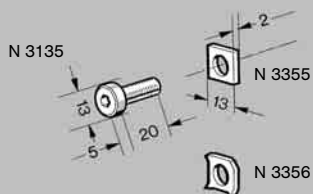

Low-Head Screw M8 x 20 - N 3135

Grade 8.8 zinc coated - 5 mm key

Low-Head Screw M8 x 20 stainless steel - N 3525

Low-Head Screw M8 x 20 Nyloc - N 3185

Square washer - N 3355 zinc plated steel - provides better pressure distribution inside the slot - for hex and socket head screws, can be tilted and inserted inside the slot.

Square washer stainless steel - N 3555

Electrical continuity washer - N 3356

Tightening torque, maximum load, deflection under load, pages 73 to 75.

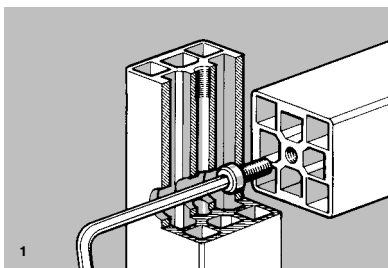

For applications where the standard assembly with the M8 x 43 through-bolt cannot be used.

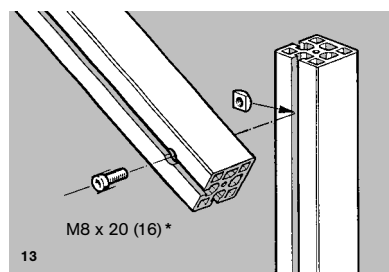
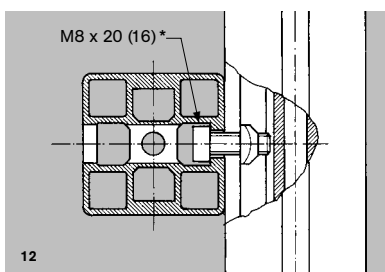
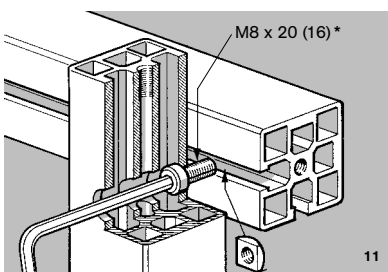
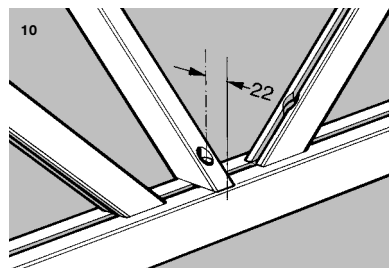
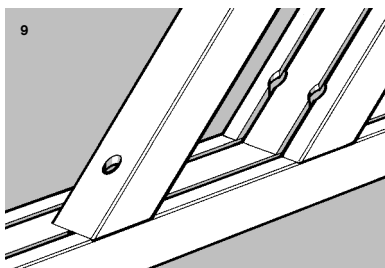
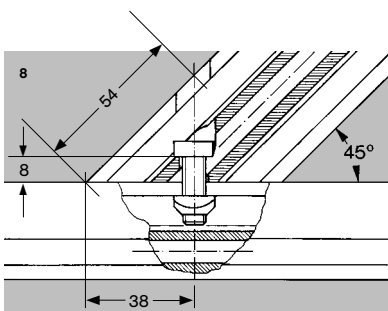
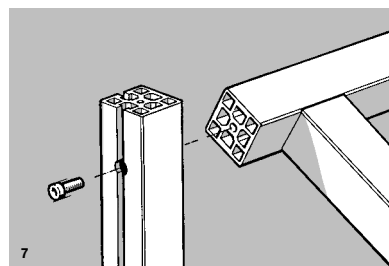
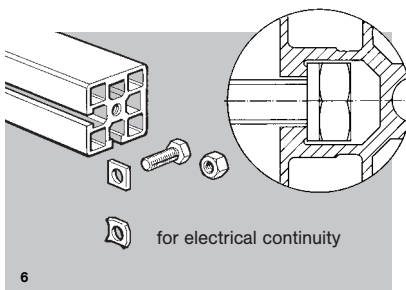
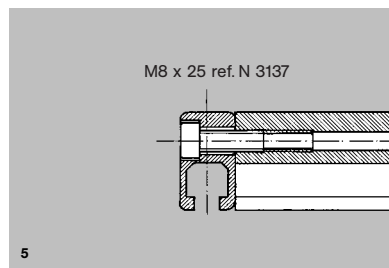
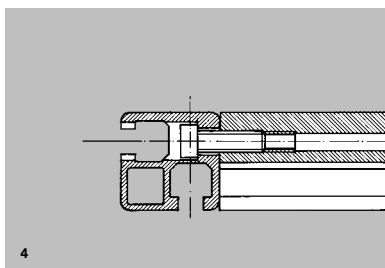
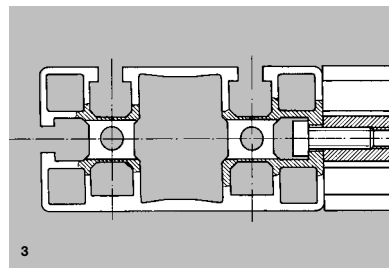
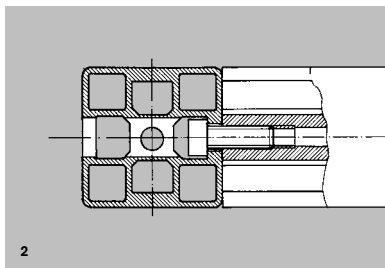

*) Fig. 11, 12, 13: M8x16 screw, when assembling without pressure washer and nut inside a profile slot of heavy profiles.

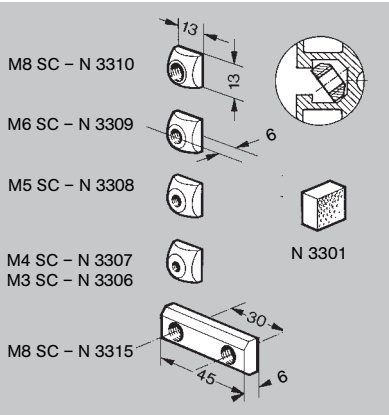

Nut SC zinc plated steel - can be tilted and inserted in the slot, thus permitting the attachment of various elements to existing structures without any need for dismantling. Plastic foam retainers N 3301 help to retain the inserted screw in position in vertical slots. Spring nuts ...RSC and ...RLSC see on bottom of this page.

- M8 SC - N 3310
- M6 SC - N 3309
- M5 SC - N 3308
- M4 SC - N 3307
- M3 SC - N 3306
- M8 SC stainless - N 3510

Plastic foam retainer - N 3301, for fixing the nut inside vertical slots.

Double nut M8 DSC - N 3315 in zinc plated steel - to be tilted in the slot. May be locked by using a M8 grub screw in one thread (figure 3).

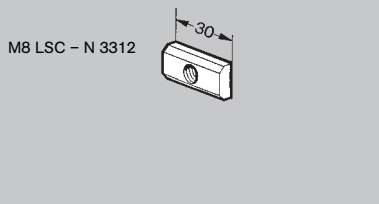
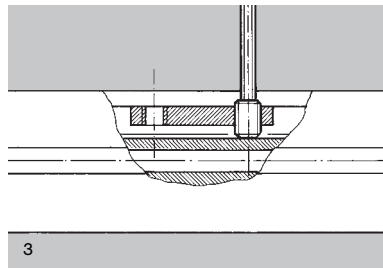
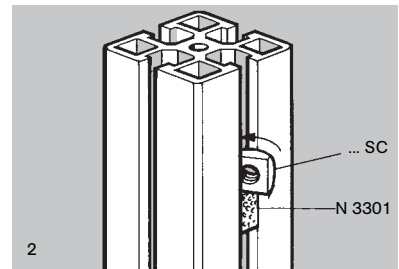
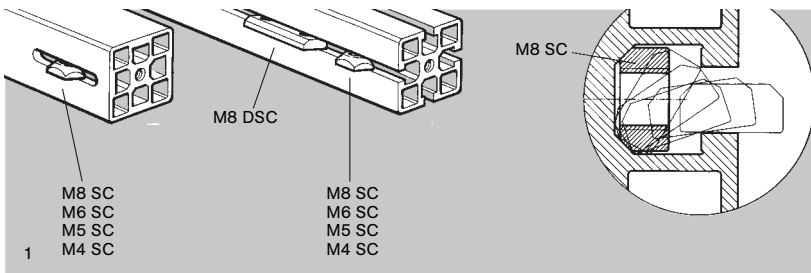

Long nut M8 LSC - N 3312
Long version of the nut M8 SC, preferred for use in adjustable elements.
Material : zinc plated steel.

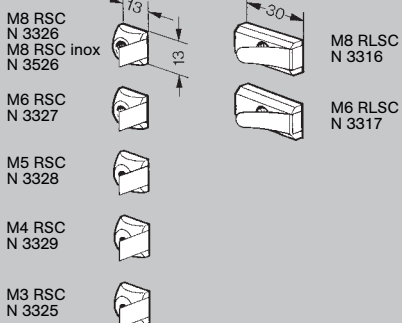
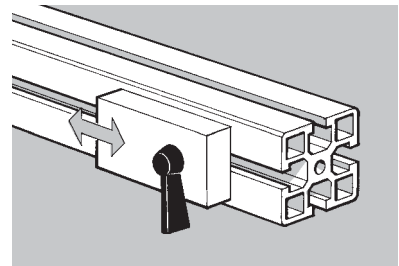

Spring nuts, M8/6/5/4 RSC.
This version of the nut incorporates a spring that maintains its position within the profile slot.

Spring nuts, long M8/6 RLSC
A long version of the SC-nut which incorporates a spring that maintains its position within the profile slot.
Materials : nut zinc plated steel, (N 3526 stainless steel) spring stainless steel.

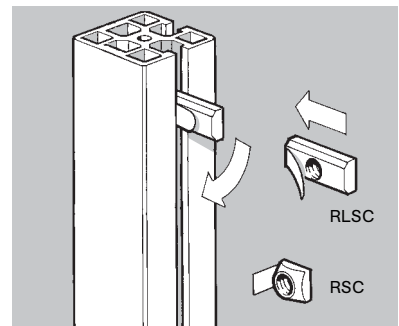

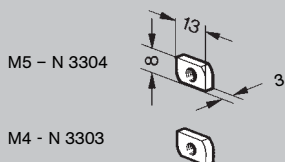

Quarter turn nut - for quick assembly of light parts. For parts with safety requirements please note that these nuts are not self locking in position. In these instances use M5 SC and M4 SC nuts.

M5 - N 3304
M4 - N 3303

Material : zinc plated steel.

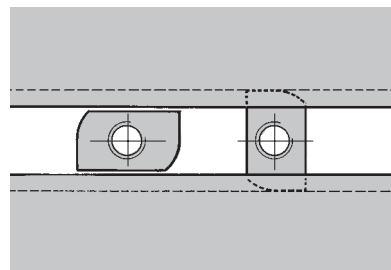

N1149

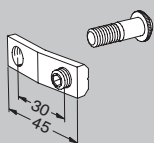

Adjustable coupling T - N 1149 :
For the assembly of all closed and slotted profiles on the slot of a NORCAN profile.

- Can be assembled easily
- For the assembly of profiles which need to be adjustable
- For the assembly of profiles where the use of a central screw is not possible, for instance crucifix mountings.
- Provides electrical continuity.

Assembly : screw the M8 x 25 knurled head screw into the end of the profile A (fig.1). Insert coupling into the slot of profile B (fig 2). Slide profile A into position and tighten the grub screw to its maximum (fig. 3).

The adjustable coupling T is compatible with the locking finger N 1132 (p. 26).

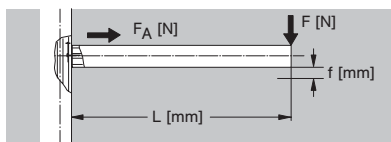
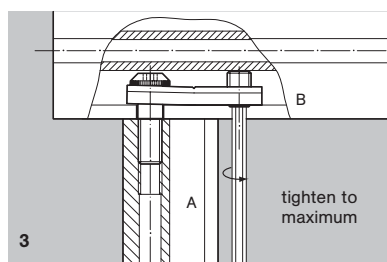
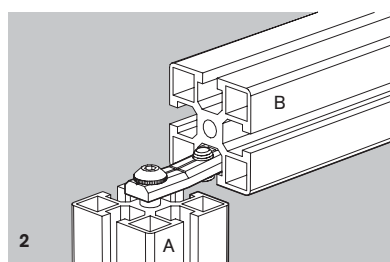
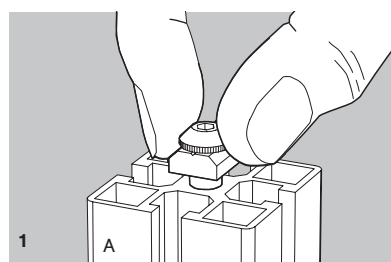
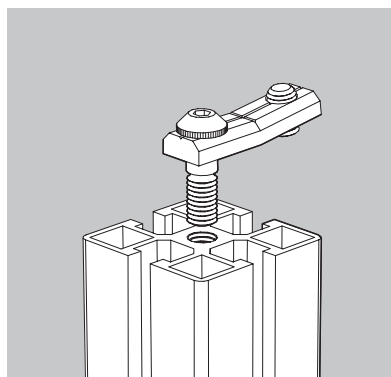

Method T1 : NORCAN 45 x 45mm fixed with 1 adjustable fixing N 1149

$$F_{A \text{ maxi}} = 3600 \text{ N}$$

$$F_{\text{maxi}} \text{ (for } L=0) = 1800 \text{ N}$$

$$(F \cdot L)_{\text{maxi}} = 80 \text{ Nm}$$

$$f \approx 40 \cdot 10^{-12} FL^3 + 80 \cdot 10^{-9} FL^2$$

Ex. $F = 100 \text{ N}$; $L = 1000 \text{ mm} \rightarrow f \approx 12 \text{ mm}$

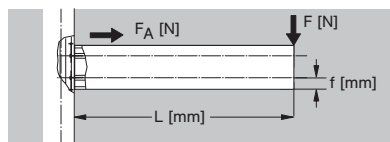

Method T2 : NORCAN 45 x 90mm fixed with 2 adjustable fixings N 1149

$$F_{A \text{ maxi}} = 7200 \text{ N}$$

$$F_{\text{maxi}} \text{ (for } L=0) = 3600 \text{ N}$$

$$(F \cdot L)_{\text{maxi}} = 270 \text{ Nm}$$

$$f \approx 5,5 \cdot 10^{-12} FL^3 + 24 \cdot 10^{-9} FL^2$$

Ex. $F = 100 \text{ N}$; $L = 1000 \text{ mm} \rightarrow f \approx 3 \text{ mm}$

Maximum load on adjustable coupling T - N 1149 : These fixings are not as strong as a M8 x 43 or a M8 x 20 central screw.

When occasionally overloaded to a maximum of 170% of the values FA and (F·L) the adjustable coupling deforms elastically and return into its original position once the tension is released.

N 1132

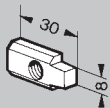

Locking finger - N 1132. Prevents the rotation of profiles assembled with a single central screw when subjected to **high** rotational torque M_r .

Material: zinc plated steel.

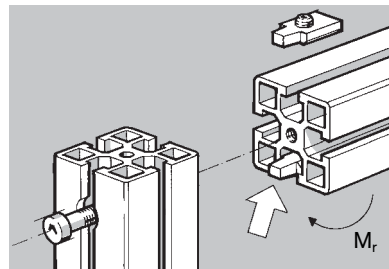

N 1145
N 1144
N 1143

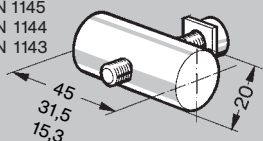

Angled assembly coupling 45 long - N 1145 with M8x30 screw and square washer.
Angled assembly coupling 31,5 long - N 1144 with M8x30 screw and square washer.
Angled assembly coupling 15,3 long - N 1143 with M8x30 screw and square washer.
 To allow assembly from 30...90°

Material: aluminium alloy.

For 45° angle couplings, see page 23 and 77.

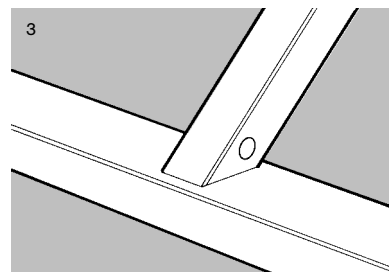
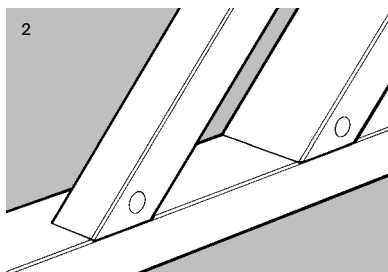
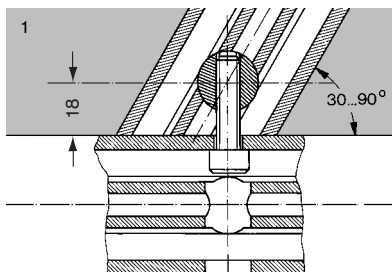

N 1140

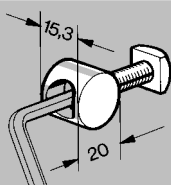

Assembly nut - N 1140 with M8 x 30 screws and M8 SC nut.
 To assemble cross joints, fixed or adjustable, at right angles. Tightening via angled key N 5712, the access opening is closed with plug N 1717.

Material: aluminium alloy

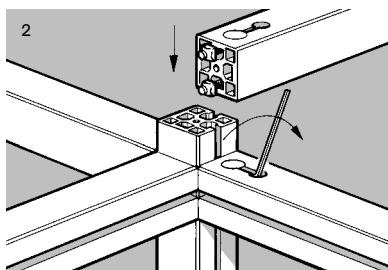
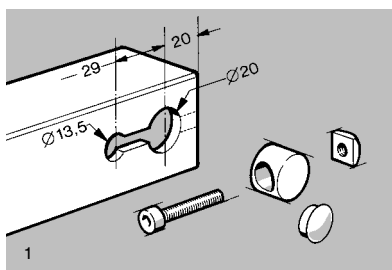

The example shows an assembly possible with M6 x 30 and M6 SC nut.

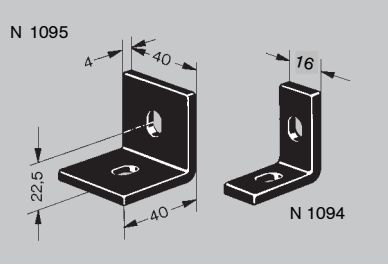

Steel corner triangle 16 x 40 - N 1094
Steel corner triangle 40 x 40 - N 1095
 with 2 M8 x 20 screws 2 washers and 2 M8 SC nuts.
 Material: steel with black epoxy finish.

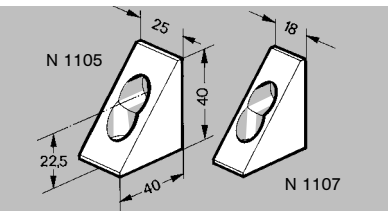
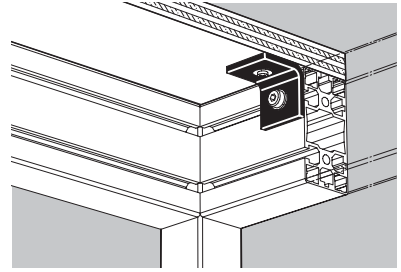

Corner triangle 40 x 25 - N 1105
Corner triangle 40 x 18 - N 1107
 with 2 M8 x 20 screws and 2 M8 SC nuts.
 - facilitate the assembly of easily adjustable elements
 - increase the rigidity of existing structures (see assembly B... page 54 and 55)
 - for the assembly of various panels and elements
 - interconnect profiles where the central screw arrangement cannot be used.
 Material: anodised aluminium alloy.

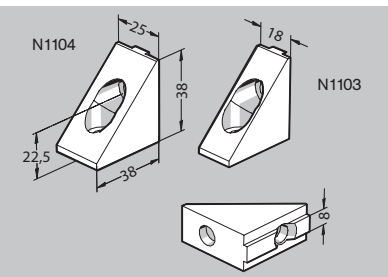
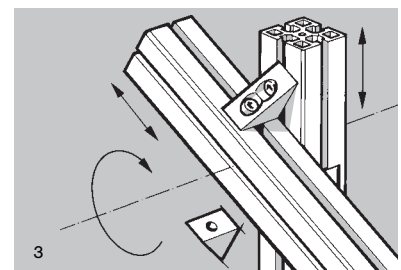
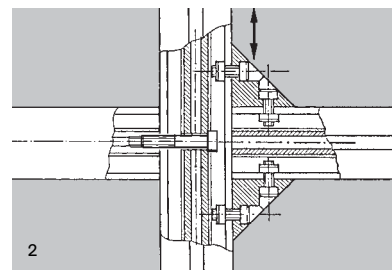
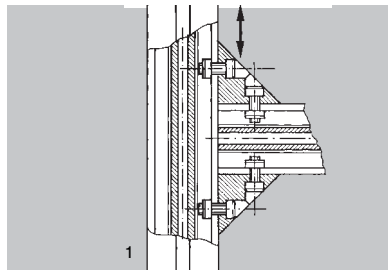

Heeled corner triangle 40 x 25 - N 1104
Heeled corner triangle 40 x 18 - N 1103
 - with 2 M8 x 20 screws and 2 M8 SC nuts.
 - for adjustable non-rotating assemblies
 Material: anodised aluminium alloy.

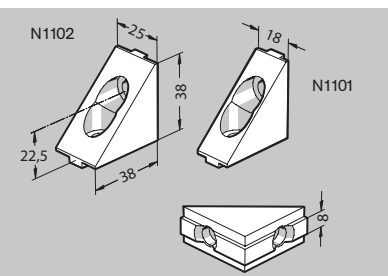
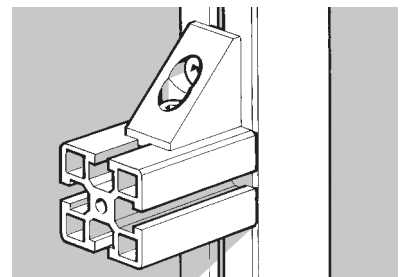

Corner triangle with 2 heels 40x25 - N 1102
Corner triangle with 2 heels 40x18 - N 1101
 with 2 M8x20screws and 2 M8SC nuts
 - for adjustable non-rotating assemblies on two axes and the assembly of orthogonal joints using the profile slots.
 Material : anodised aluminium alloy.

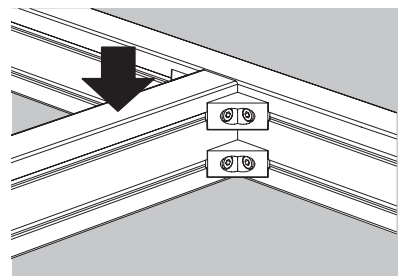

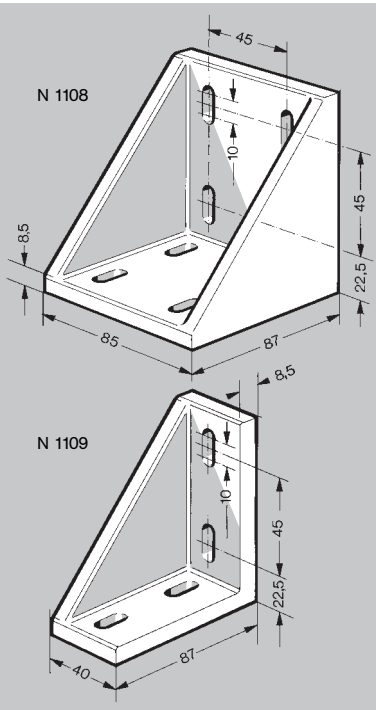

Corner triangle 87 x 85 - N 1108 : with 8 M8 x 25 screws, washers and M8 SC nuts.

Angular tolerance: $\pm 0,3^\circ$
 Material : cast aluminium alloy, peel shot
 Rp 0,2 \cong 220 Nmm⁻²; Rm \cong 260 Nmm⁻²

Corner triangle 87 x 40 - N 1109 : with 4 M8 x 25 screws, washers and M8 SC nuts.

Angular tolerance: $\pm 0,3^\circ$
 Material : cast aluminium alloy, peel shot
 Rp 0,2 \cong 220 Nmm⁻²; Rm \cong 260 Nmm⁻²

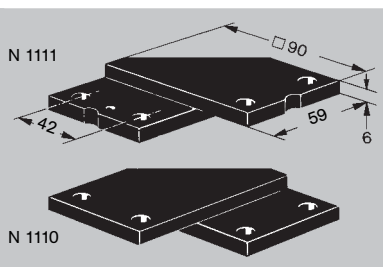

Left-hand assembly plate (marked) - **N 1111** with 4 M8 x 20 screws and 4 M8 SC nuts

Right-hand assembly plate - **N 1110** with 4 M8 x 20 screws and 4 M8 SC nuts.

These assembly plates are for right angle adjustable joints.

Material : black anodised aluminium alloy.

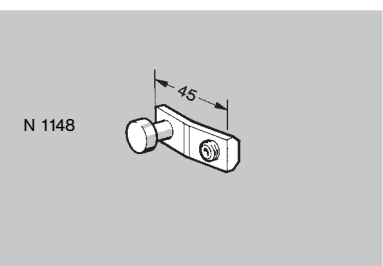
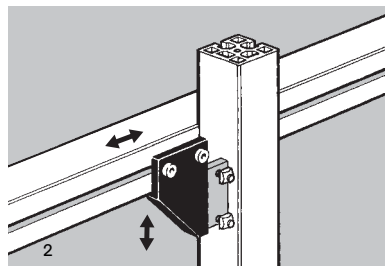
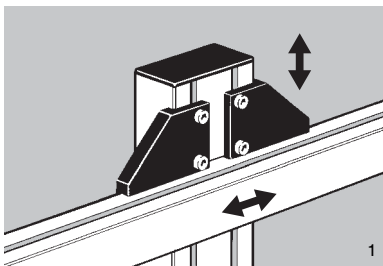

Adjustable coupling X - N 1148

With grub screw M8 x 12
 Ideal for two axis adjustment under light load.

Material : zinc plated steel.

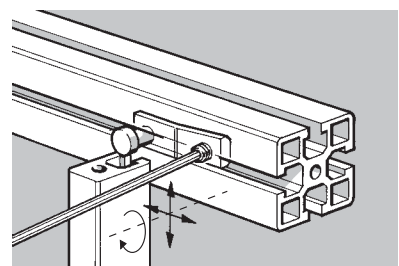

N 1123

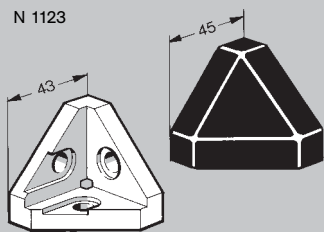

3-way block with black triangular cap - N1123

3-way block with grey triangular cap - N1139 : with 3 M8x20 screws, for the assembly of 45 x 45 triangular profiles N 0295.

Material: cast aluminium alloy, PA fibreglass.

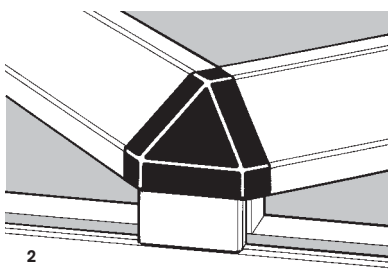
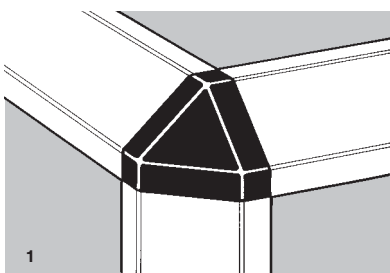

N 1122

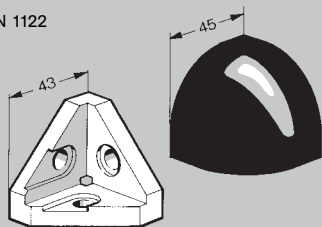

3-way-block with black 1/4 round cap - N1122

3-way-block with grey 1/4 round cap - N1138 : with 3 M8 x 20 screws for the assembly of 45x45 1/4 round profiles N 0294.

Material: cast aluminium alloy, PA fibreglass.

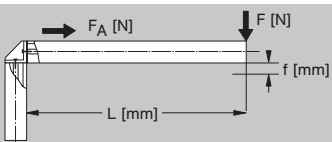
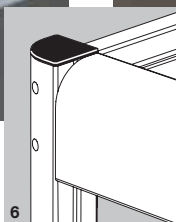
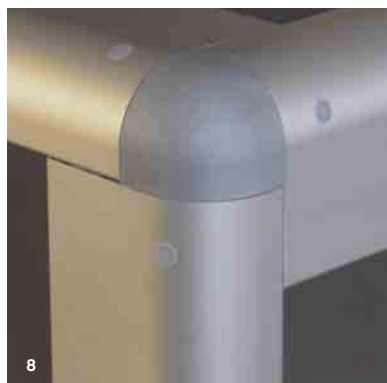
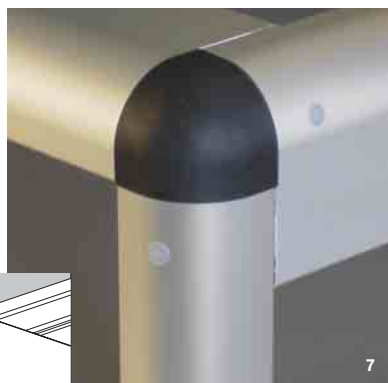
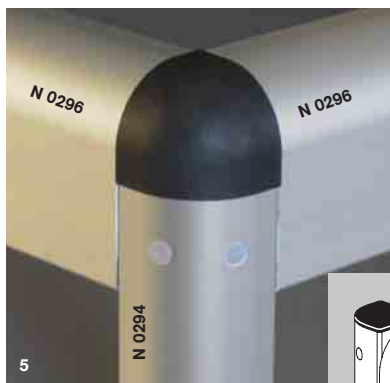
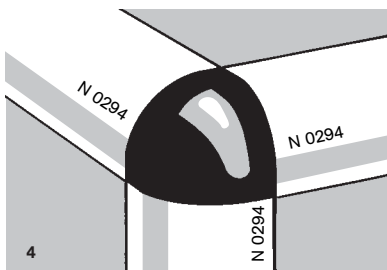

$F_{A \text{ max}} = 1800 \text{ N}$
 $F_{\text{max}} (\text{pour } L=0) = 1800 \text{ N}$
 $(F \cdot L)_{\text{max}} = 40 \text{ Nm}$
 $f \approx 40 \cdot 10^{-12} FL^3 + 2 \cdot 10^{-7} FL^2$
 Ex. $F = 10 \text{ N}$; $L = 1000 \text{ mm} \rightarrow f \approx 2,5 \text{ mm}$

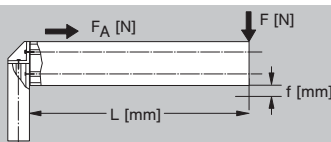

$F_{A \text{ max}} = 6000 \text{ N}$
 $F_{\text{max}} (\text{pour } L=0) = 3600 \text{ N}$
 $(F \cdot L)_{\text{max}} = 135 \text{ Nm}$
 $f \approx 40 \cdot 10^{-12} FL^3 + 2 \cdot 10^{-8} FL^2$
 Ex. $F = 100 \text{ N}$; $L = 1000 \text{ mm} \rightarrow f \approx 5 \text{ mm}$



Maximum loads on 3-way blocks : naturally, mountings with 3-way blocks cannot have the same mechanical qualities as mountings with central M8x43 or M8x20 screws (see p. 74). Where large couples exist it is necessary to reinforce the structure (fig.3) or alternatively use solutions like fig.5 and 6.

The results of the tests besides show the elastic limit.

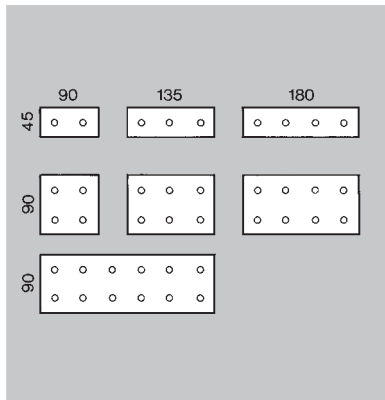
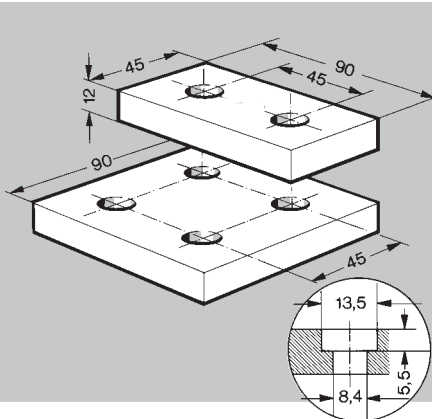

Assembly plates with M8 x 20 screws and M8 SC nuts :

- 45 x 90 x 12 - N 1150
- 45 x 135 x 12 - N 1171
- 45 x 180 x 12 - N 1172
- 90 x 90 x 12 - N 1160
- 90 x 135 x 12 - N 1181
- 90 x 180 x 12 - N 1182
- 90 x 270 x 12 - N 1183

For cross mountings, axial connections, fixing on straight surfaces (fixings on the floor see anchor angles p 65 and 66), adjustable mountings and for the fixing of accessories.

On request, milling and drilling to customers drawing.

- See :
- Mounting bases (p64)
 - Pneumatic plates (p 69)

Material : plain anodised aluminium.

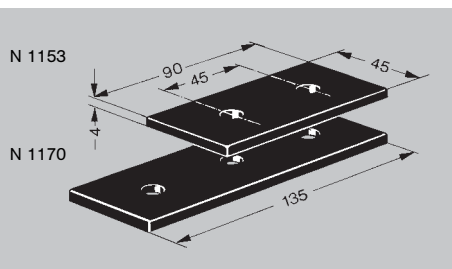
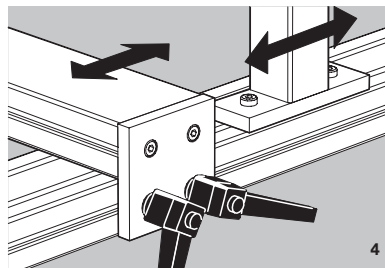
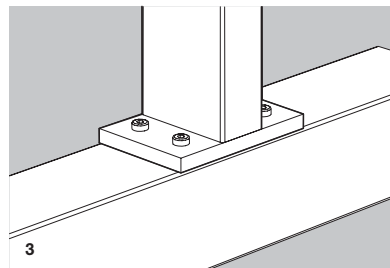
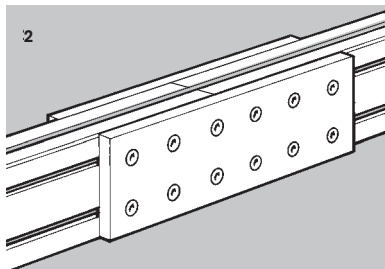
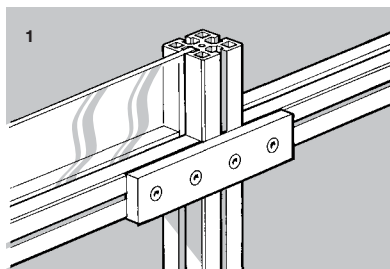

Steel assembly plates with M8 x 20 screws and M8 SC nuts.

- 45 x 90 x 4 - N 1153
- 45 x 135 x 4 - N 1170

Economic alternative to plain aluminium plates , essentially for moderate loads.

Material : steel with black epoxy coating.

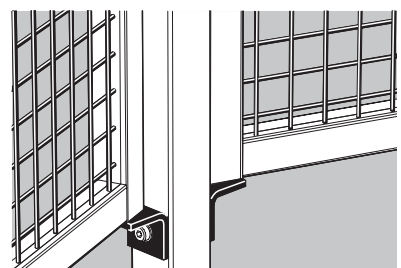
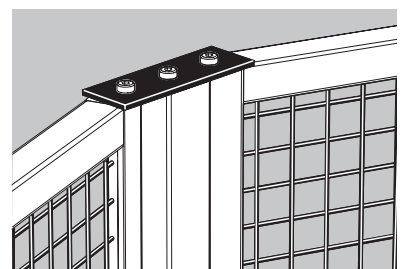

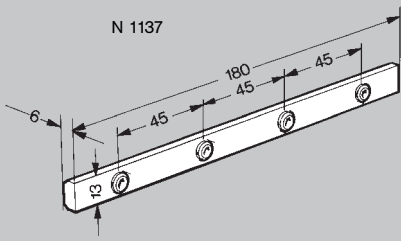

Connecting bar - N 1137 with 4 grub screws for axial connection of profiles under low load.

Material: zinc plated steel.

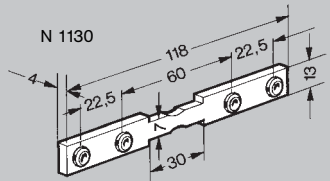
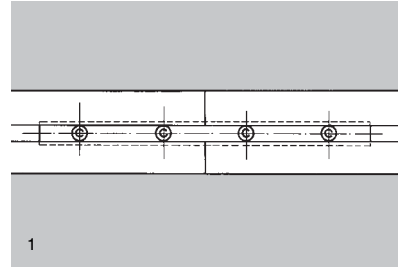

Angle connection bar - N 1130 with 4 grub screws for end-to-end joints and angle joints under low load.

Material: zinc plated steel.

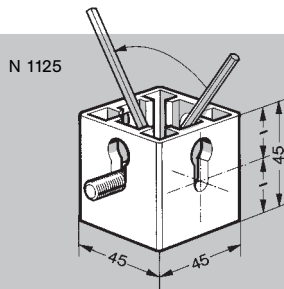
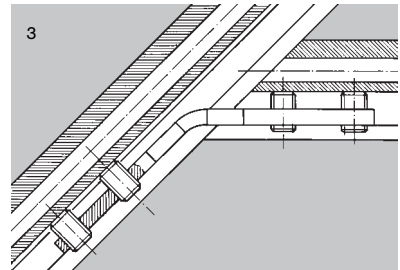
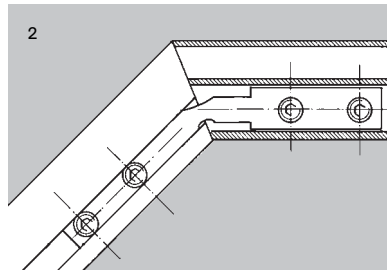
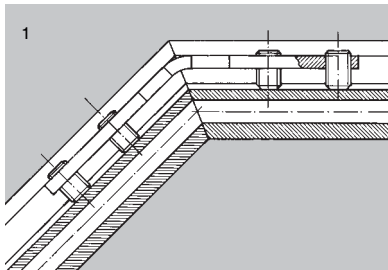

5 - Way block - N 1125 with 5 M8x20 screws and 1 endplate 45x45 N 1705. For crossover assembly under a moderate deflectional load.

Important! For special applications, some crossover junctions with a central screw, practically invisible from the outside, are possible. Details on application.

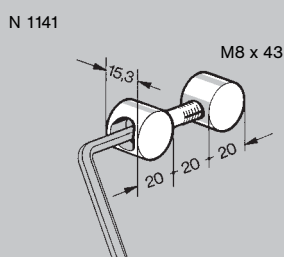
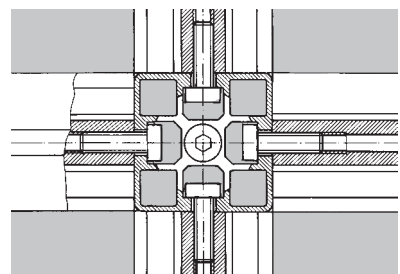

Assembly nut, double - N 1141 with M8x43 screw for end-to-end fixing of profiles under low load

Material: aluminium alloy

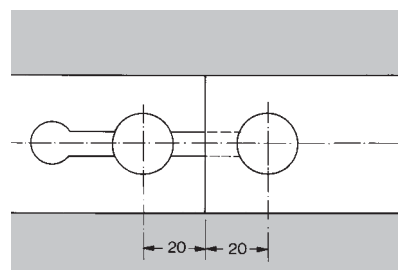

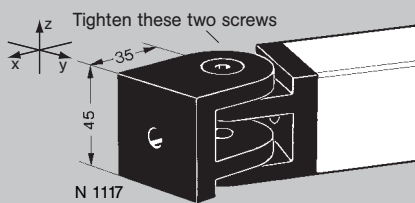

Pivot 45 x 45 - N 1117 with 2 low head screws M8x20 mm. Fits on either the cut end or the side of the profile. For fixed angle mountings from +90° to -90°. Maximum torque around the y-axis: 135 Nm (elastic limit). Material: aluminium alloy anodised black.

To prevent the pivot from turning around its fixing screw use an anti-rotation plate N 1129.

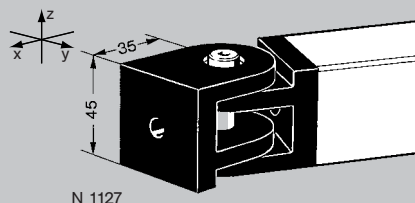
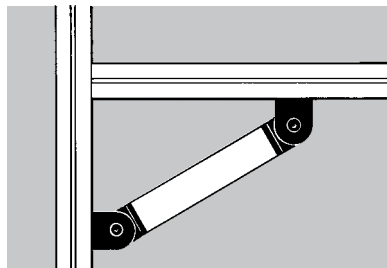

Pivot 45 x 45, dynamic - N 1127 with 2 low head screws M8x20 mm. Fits on either the cut end or the side of the profile. For dynamic mountings from +90° to -90°. Maximum torque around the y-axis: 135 Nm (elastic limit). Material: aluminium alloy anodised black.

To prevent the pivot from turning around its fixing screw use an anti-rotation plate N 1129.

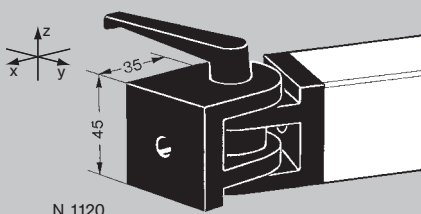
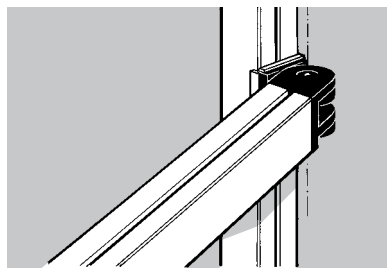

Pivot 45 x 45 with locking handle - N 1120 with 2 low head screws M8x20 mm. Fits on either the cut end or the side of the profile. For fixed angle mountings from +90° to -90°. Maximum torque around the y-axis: 135 Nm (elastic limit).

Tightening the handle with 20 Nm will lock the pivot with about 45 Nm.

Material: aluminium alloy anodised black

To prevent the pivot from turning around its fixing screw use an anti-rotation plate N 1129.

N 1129

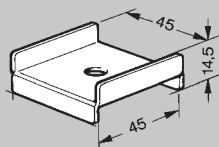

thick 1,5

Antirotation plate - N 1129: to prevent profiles and accessories of 45 mm width from turning around the axis of their fixing screw.

Elastic limit: $M_r = 80 \text{ Nm}$

Material: 1,5 mm stainless steel.

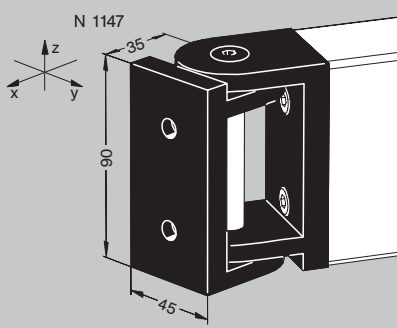
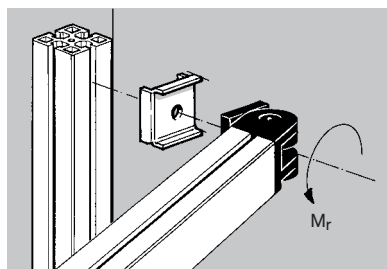

Pivot 45x90 - N1147 with 2 low head screws M8x20. Fits on either the cut end or the side of the profile. For fixed angle mountings from +90° to -90°.

Maximum torque around the x-axis (sliding of the M8x20 screw): 81 Nm.

Maximum torque around the y-axis: 230 Nm.

Material: Aluminium alloy anodized black.

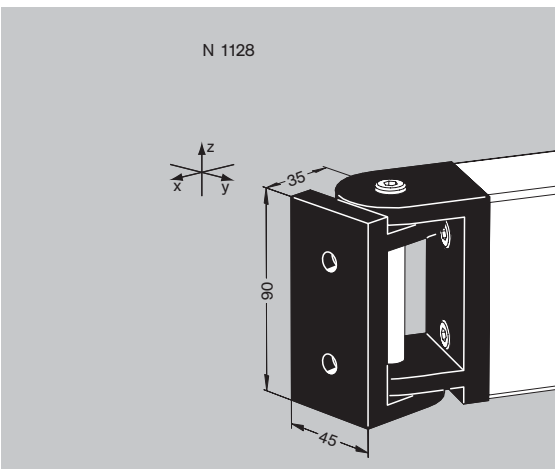

Pivot 45x90, dynamic - N 1128 : with 2 low head screws M8 x 20. Fits on either the cut end or the side of the profile. For dynamic angle mountings from +90° to -90°.

Maximum torque around the x-axis (sliding of the M8 x 20 screw) : 81 Nm.

Maximum torque around the y-axis : 230 Nm.

Material : Aluminium alloy anodized black.

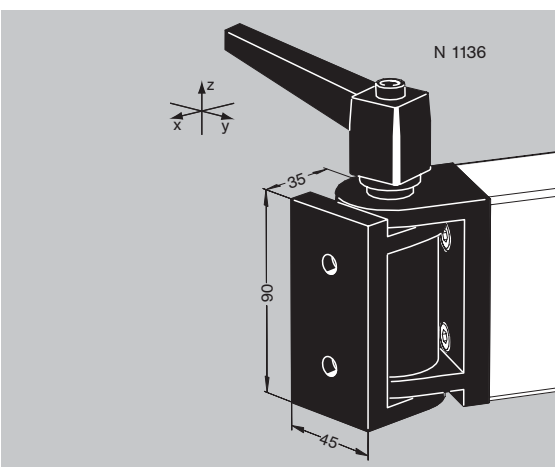

Pivot 45x90 with locking handle - N 1136 : with 2 low had screws M8 x 20. Fits on either the cut end or the side of the profile. For angle mountings from +90° to -90°. Tightening the handle with 20 Nm will lock the pivot with about 45 Nm.

Maximum torque around the x-axis (sliding of the M8 x 20 screw): 81 Nm.

Maximum torque around the y-axis : 230 Nm.

Material : Aluminium alloy anodized black, handle PA black.

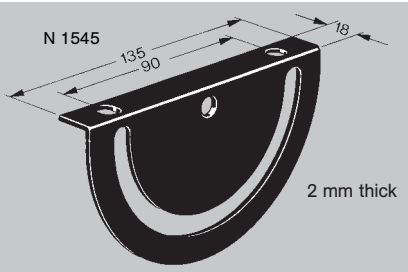

Steel adjustable plate - N 1545 with screws and nuts for shelves and other adjustable assemblies.

Tightening the screw with 20 Nm will lock the plate with about 160 Nm.

Material: steel with black epoxy coating.

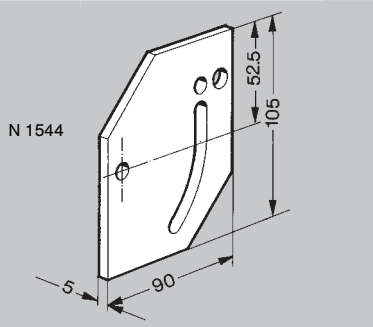
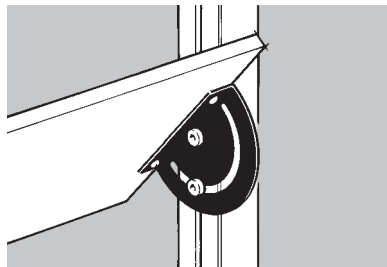

Plate, footrest, adjustable N 1544 with 3 M8 x 20 screws, 2 M8 SC nuts 3, washers and 1 locking finger. The profile "A" can be adjusted from 0° and 45°.

Tightening the screw with 20 Nm will lock the plate with about 160 Nm.

Material: plain anodised aluminium.

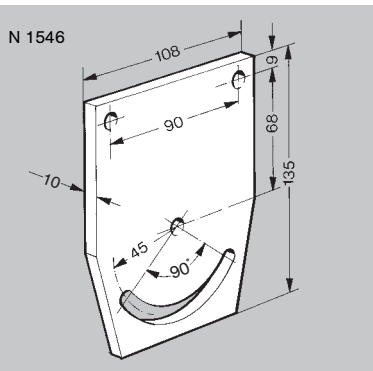
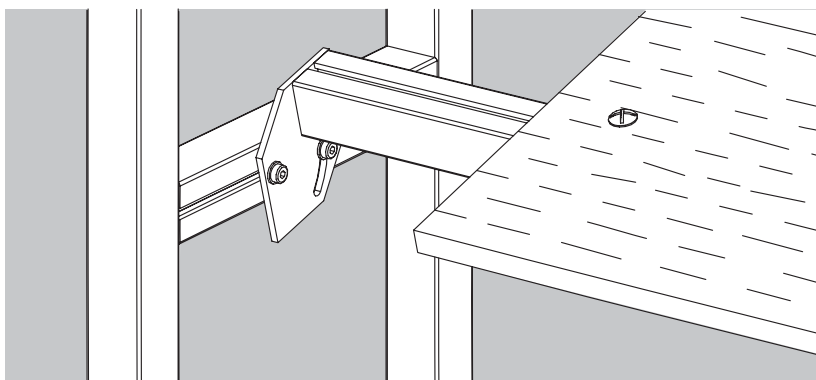
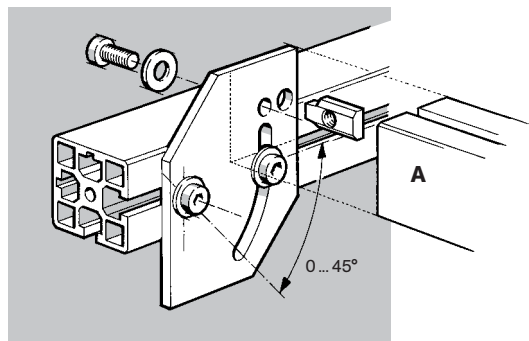

Aluminium adjustable plate N 1546 with 3 M8 x 20 screws, M8 SC nuts and washers. For adjustable structures, accessories, conveyors etc.

Tightening the screw with 20 Nm will lock the plate with about 160 Nm.

Material: plain anodised aluminium.

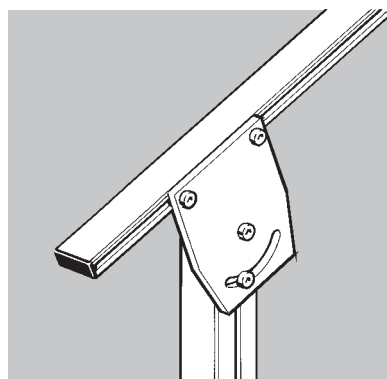

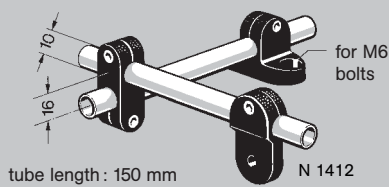

Sensor-support - N 1412: adjustable support for photocells, limit-switches and other types of switches with a diameter of 19 mm used for automation.

Material: black polyamide, tubings stainless steel or anodised aluminium.

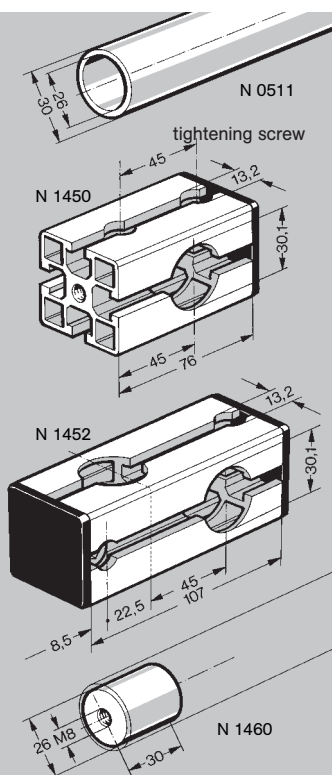
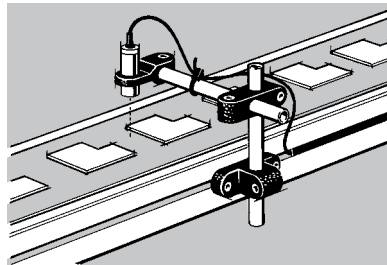

Tubing 30 x 26 - N 0511 anodised aluminium.

Weight per linear meter : 0,475 kg/m for a section of 175 mm²
 Inertia (deflection) : 1,7·10⁴ mm⁴
 Inertia (twisting) : 3,5·10⁴ mm⁴

These tubes can be used as fixing and spacing elements and are low cost and multipurpose. For connection to NORCAN profiles and interconnection between them, we currently offer the three following components. Other connection parts are available on request.

Mounting Block for tubing Ø 30 - N 1450: made from 45 x 45 mm NORCAN profile - tightening of the tube with a M8x20 screw and nut on the profile open side, and direct fixing on NORCAN profile with a M8x43 screw or with a screw in the tapped end.

Cross mounting Block - N 1452: made from 45 x 45 mm NORCAN profile - the tube is clamped to the profile with a M8x20 screw and nut. It can be fitted to other profiles by replacing this screw with a M8x43 screw.

Tapped Plug - N 1460: in aluminium - For gluing in the end of the tube. Allows the tube to be fitted with a screw for mounting in the profile slots.

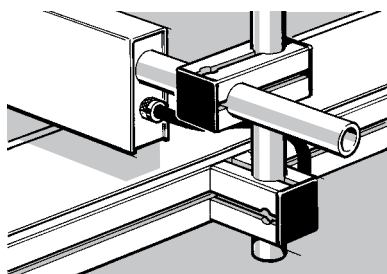

p 41

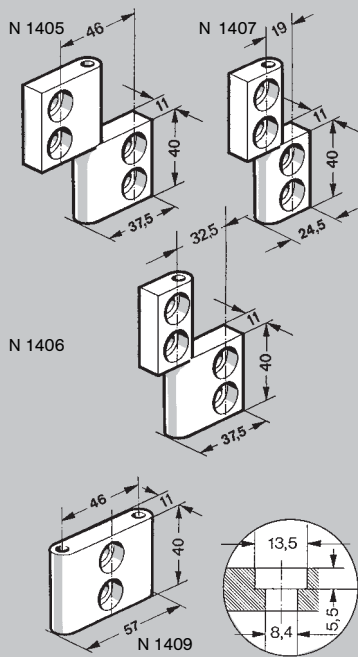

Hinges with 4 M8x20 screws and M8 SC nuts : consist of two plates in aluminium and one zinc plated steel shaft. The hinges can face left or right and the shaft is locked when assembling. Scale drawing on page 95.

- N 1405** - centre distance 46 mm
- N 1406** - centre distance 32,5 mm
- N 1407** - centre distance 19 mm

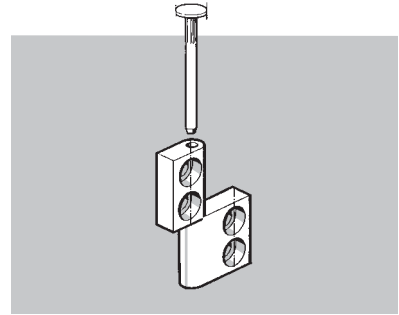

Double hinge plate - N 1409 with 2 M8x20 screws and 2 M8 SC nuts (pin, shaft) for assembly of juxtapositioned hinges on a central 45 mm upright (see fig. 9 below).

Important! For the design of doors and windows, see our technical section «doors and windows» p. 79.

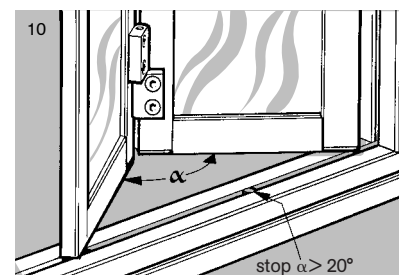
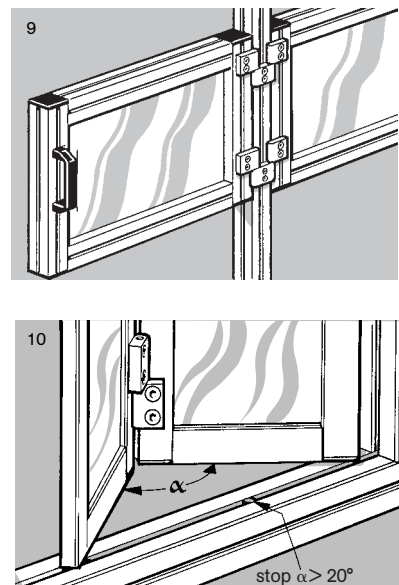
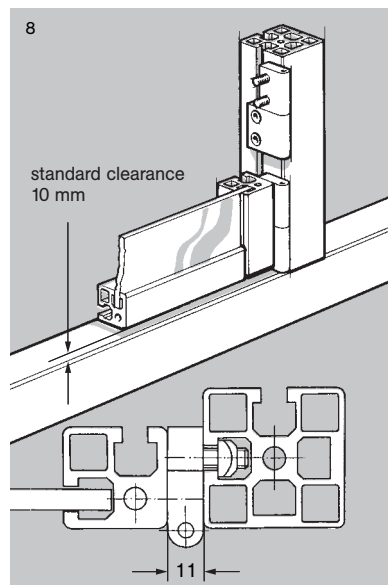
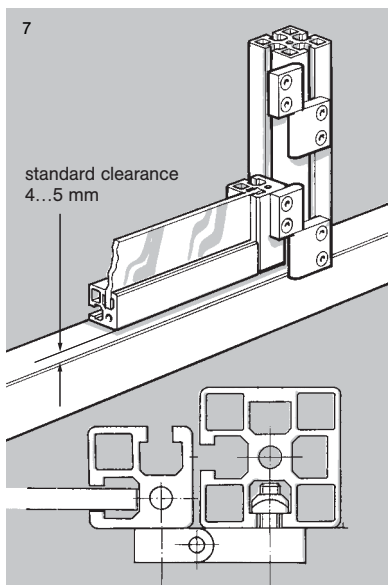
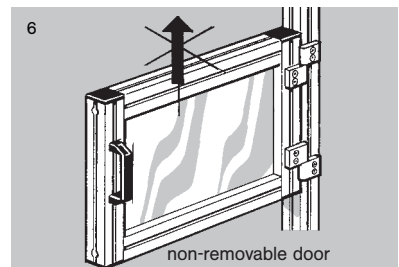
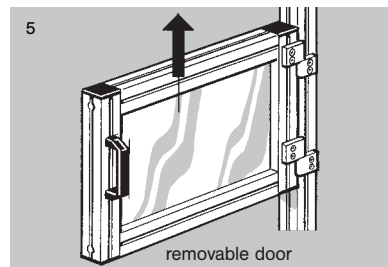
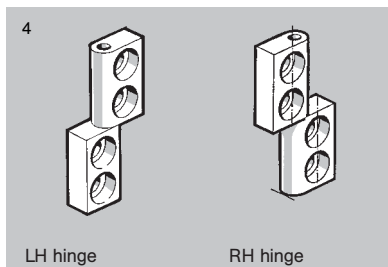
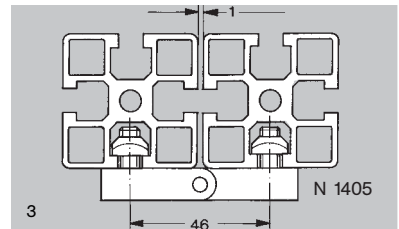
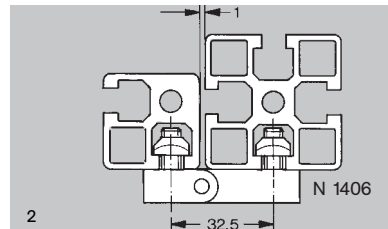
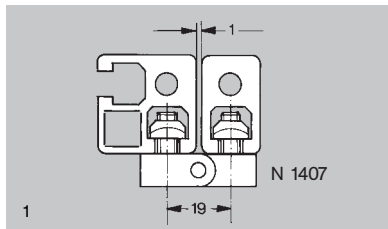

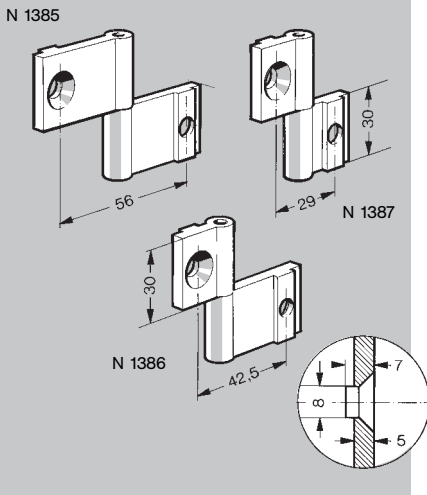

Hinges, blind with 2 M8 x 16 screws and M8 SC nuts : consist of two plates in aluminium and one zinc plated steel shaft. The hinges can face left or right and the shaft is locked when assembling.

N 1385 - centre distance 56 mm (fig. 4)

N 1386 - centre dist. 42,5 mm (fig. 3)

N 1387 - centre distance 29 mm (fig. 2)

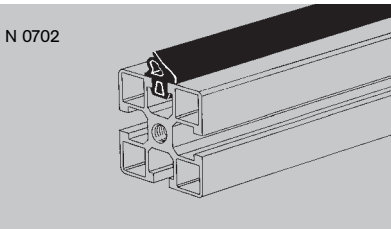
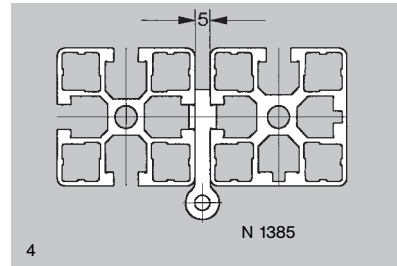
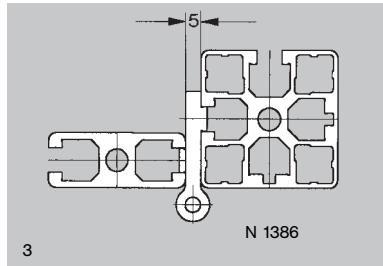
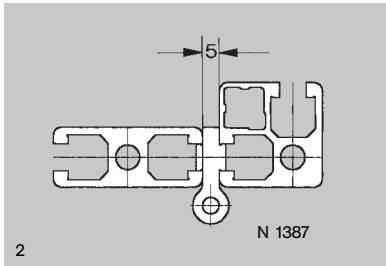
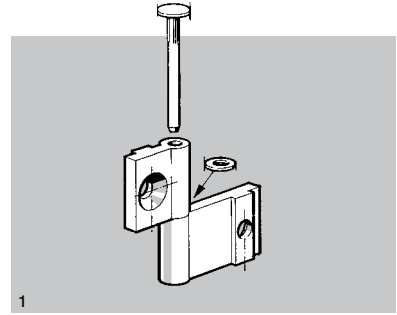

Door sealing strip - N 0702 Seal profile for opening doors - can be used as a stop for sliding doors or carriages of linear guidance systems.

Available in 20 m length.

Material : black nitrile rubber.

Important : doors with seal profiles should always be equipped with a lock, large doors with 2 or 3 locks or a locking handle with rod N 1426 (p. 40).

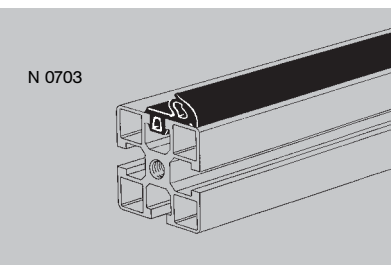
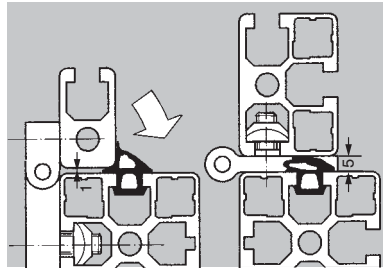
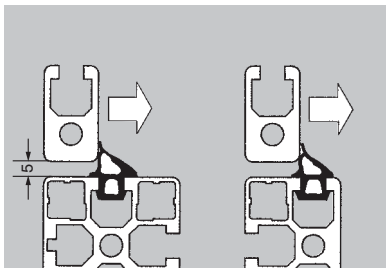

Door sealing strip, off-centre N 0703

Seal profile for opening doors

Available in 20 m length.

Material : black nitrile rubber.

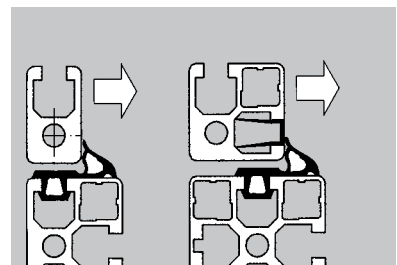

N 1474

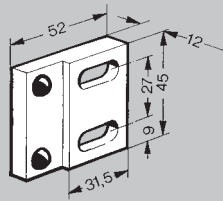

Door stop with buffer - N 1474 :
with 2 low head screws M8x20 mm
and 2 M8 SC nuts for opening doors.
Material : plain anodised aluminium.

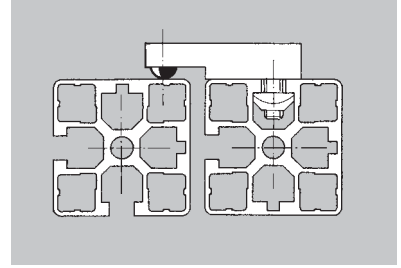

N 1413

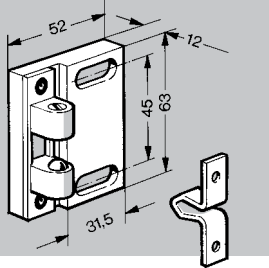

Door stop with ball latch - N 1413 :
with 2 low head screws M8x20 mm
and 2 M8 SC nuts for 31,5 (18) mm
thick opening doors in 45 (31,5) mm
thick frames.
Material: plain anodised aluminium,
latch in steel.
Ball latch see page 40.

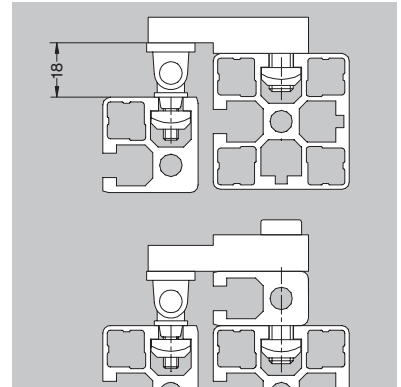

N 1416

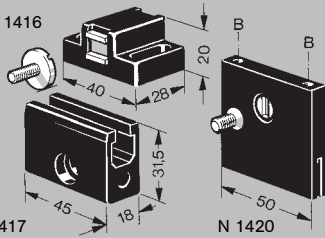

Catch double sided magnet - N 1416 :
with 2 M6 screws and 2 M6 SC nuts.
Receptacle with M5 stud and M5 SC nut. Magnetic force 15 and 30 N.
Material : black polyamide.

Support for double sided magnet - N 1417 :
with M8x25 screw and M8 SC nut.
Material : black anodised aluminium.

Catch, magnetic for 8 mm slot - N 1420 :
for assemblies like fig. 4 below.
Receptacle : M5 screw. Material : HD polyethylene
Important ! after positioning, fully tighten the screws "B".

Self adhesive receptacle for N 1416 - N 1441 stainless steel sheet 12x60x1 mm
with adhesive tape.

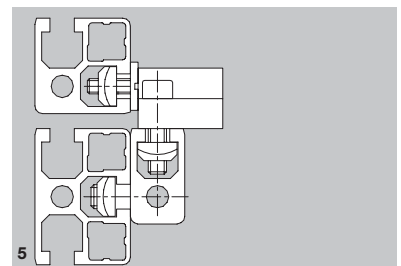
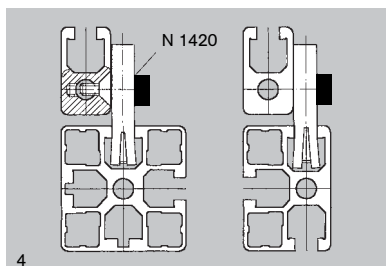
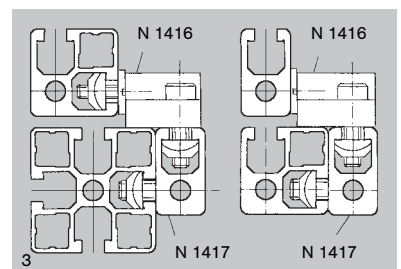
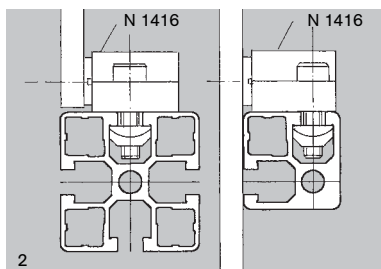
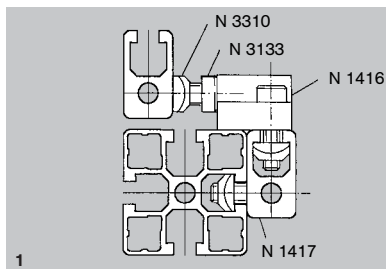

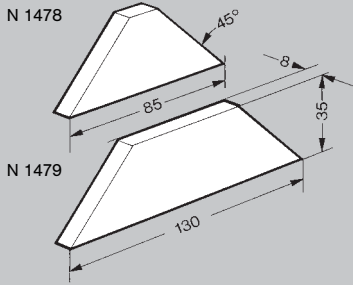

Door stop, simple - N 1478
Door stop, double - N 1479
 with two grub screws and two M8 SC nuts. For 18 mm thick doors.

Material: clear polycarbonate.

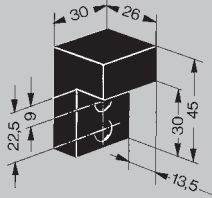
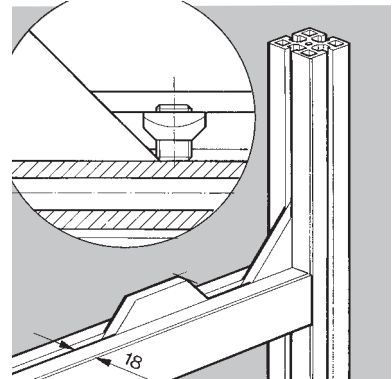

N 1473

Door stop, L-shaped - N 1473: for 18 mm thick doors in 31,5 mm thick frames and 31,5 mm thick doors in 45 mm thick frames.

Material: black polyamide.

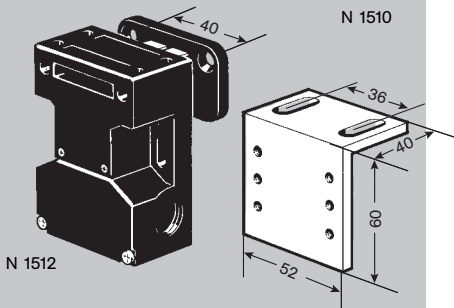
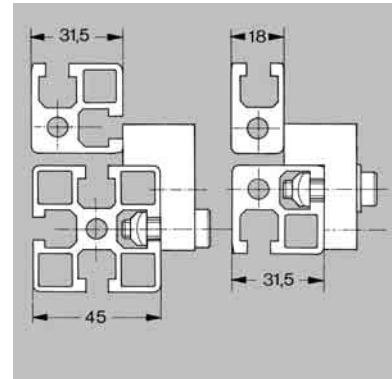

N 1512

Safety Switch Schmersal AZ 15 - ZVRK - 30N - N 1512 with nuts, screws and magnet (switch key entered = 1 contact closed). Retaining force 30 N.

Safety Switch Schmersal AZ 16 - 12 ZVRK - 30N - N 1513 with nuts, screws and magnet (switch key entered = 1 contact open, 2 contacts closed). Retaining force 30 N.

Safety Switch Trojan 2NF - 1NO 1501 with nuts, screws and key (switch key entered = 1 contact open, 1 contact closed). Key retained.

Safety Switch Trojan 2NF - 1NO 1500 with nuts, screws and key (switch key entered = 1 contact open, 2 contacts closed). With kit for key retainer.

Fastener for safety switch key - N 1511 with nuts and screws.

Fastener for safety switch - N 1510 with nuts and screws.

For assembly of these components on slotted profiles, we recommend NORCAN SC nuts M4 SC - N 3307 and M5 SC - N 3308.

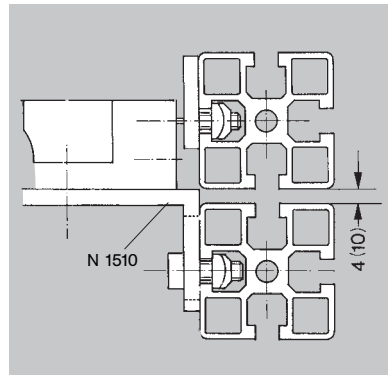
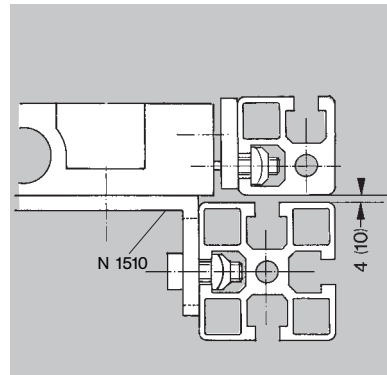
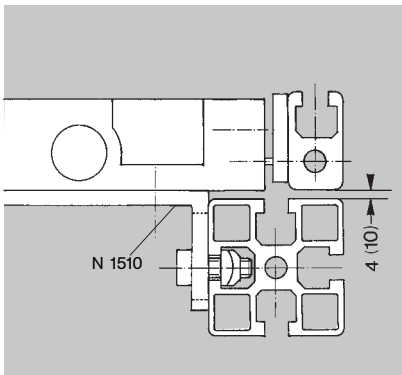

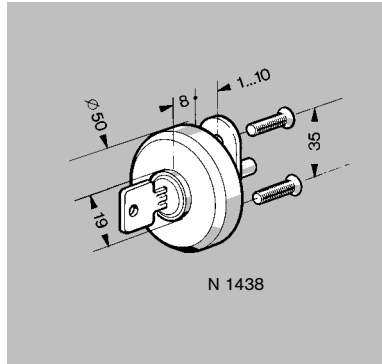
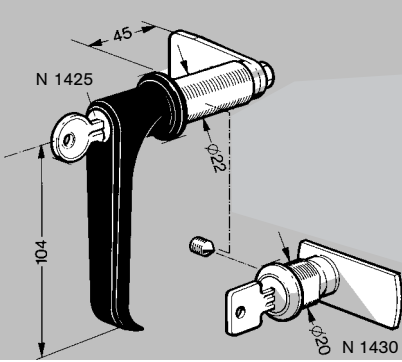

Locking handle - N 1425 : \varnothing 22 for profiles, 18 mm, 31,5 mm and 45 mm thick.

Latch lock - N 1430 : \varnothing 20 for safety housing profiles.

Lock for sliding doors - N 1438 : with fixing plate, nuts and bolts.

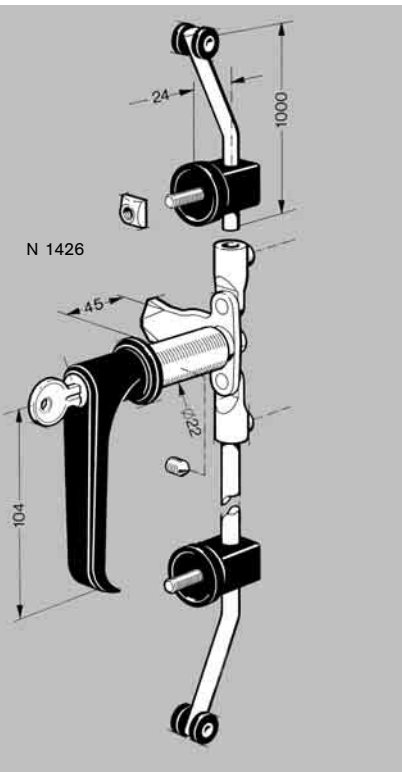

Locking handle with rod - N 1426 : \varnothing 22 mm, for 18, 31,5, and 45 mm thick doors. The rods are 1000 mm long and have to be cut to suit.

Material: polyamide / zamak / zinc coated steel.

Assembly : according to the sequence of assembly ① to ⑤ indicated on the right hand drawing. Bending and adjusting the rod is the last step.

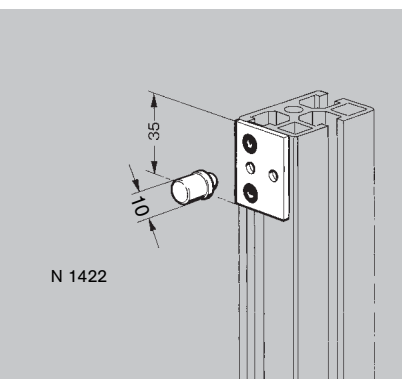
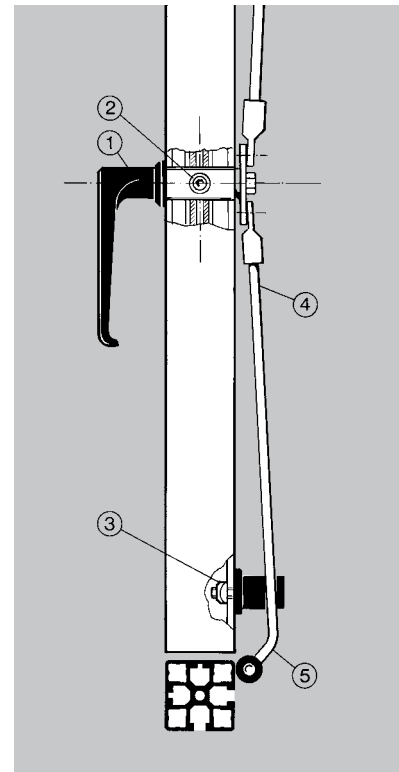

Ball latch - N 1422 with stainless steel plate and screws and nuts. For doors of moderate size (up to \approx 0,5 m²). Two ball latches should be mounted per door in a \varnothing 9,8/12 counterbore, 3 mm deep.

For larger and heavier doors use ball latch 2 N 1413 p 26.

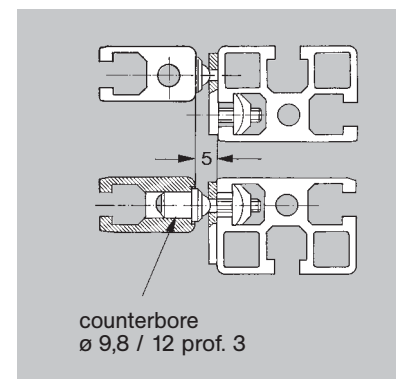

counterbore
 \varnothing 9,8 / 12 prof. 3

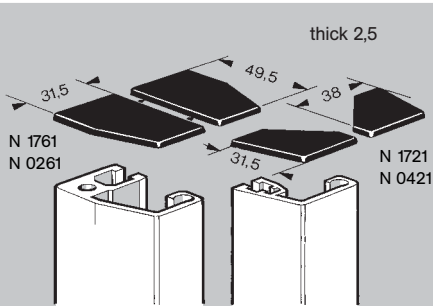

Pair of endplates for handle profile 18 x 31,5 - N 1761

Handle profile - N 0261 : makes the handle part of the structure of safety housing doors. Material : anodised aluminium. Length : 6 m or cut to suit.

Pair of endplates for handle - N 1721

Material : grey ABS.

Profile for handle - N 0421 : for long door handles cut to suit. Ideal for stiffening panels of 5 and 8 mm in sliding doors. Mounted with M6 screws. Material : anodised aluminium. Length : 6 m or cut to measure.

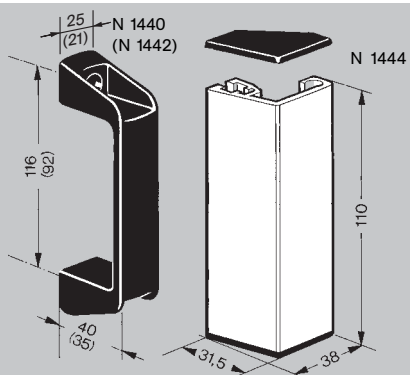
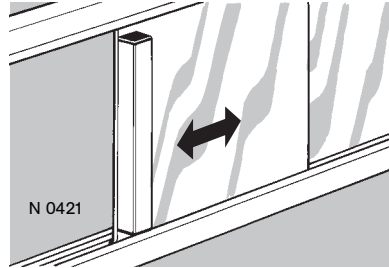
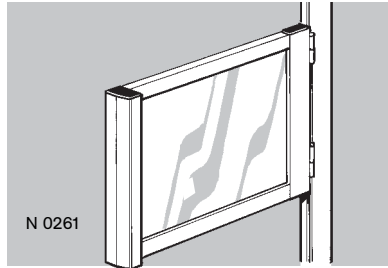

Handle 116 CTRS - N 1440 with two M8x20 screws and two M8 SC nuts. Fits on 45x45 and 45x90 mm NORCAN profiles. Material : black polyamide. Width 25 mm, over all length 139 mm.

Handle 92 CTRS - N 1442 with two M6x20 screws and hex nuts. Fits on 18x31,5 and 31,5x31,5 mm NORCAN profiles. Material : black polyamide. Width 21 mm, over all length 116 mm.

Closed handle - N 1444 with 2 screws M6x20, 2 hex nuts M6 and 2 square washers. Can be fitted to all NORCAN structures, panels and glass panels.

Material : plan anodised aluminium. End plates black ABS.

Important : the square washers 13x13x2 mm are used only for assembly into a profile slot.

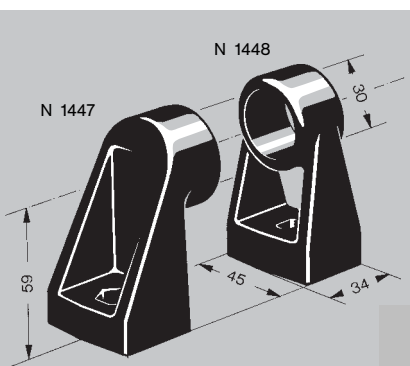

End support for ø 30 tubing N 1447 with screws and nuts.

Central support for ø 30 tubing N 1448 with screws and nuts.

For custom made handles with anodised aluminium tubing Ø30 N 0511.

Material : PA with glass fibre.

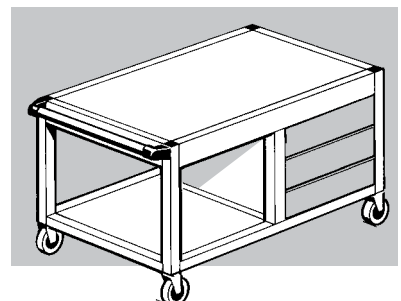
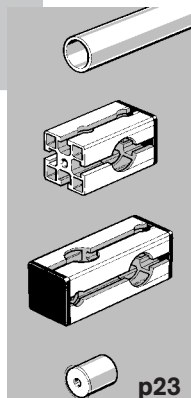
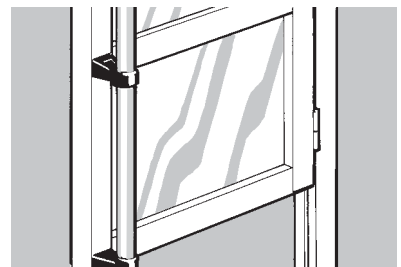

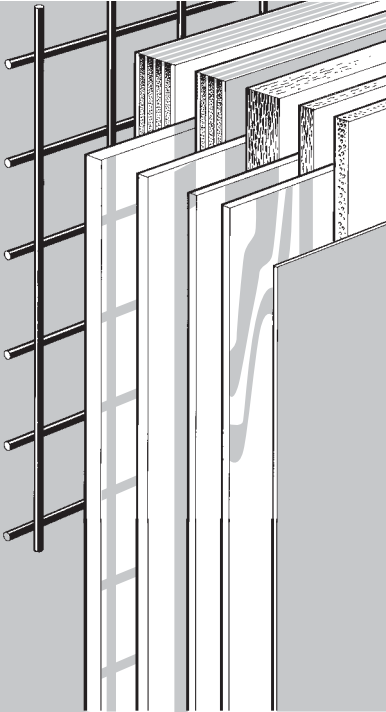

Panels cut and machined to suit

- N 6105 - melamine panel white 8 mm¹⁾
- N 6110 - melamine panel white 19 mm
- N 6135 - melamine panel beige 8 mm²⁾
- N 6140 - melamine panel beige 19 mm
- N 6310 - plywood 18 mm³⁾
- N 6320 - plywood 22 mm
- N 6340 - compound grey 8 mm
- N 6355 - foam PVC white 5 mm⁴⁾
- N 6360 - foam PVC white 8 mm⁵⁾
- N 6405 - acrylic clear 5 mm⁶⁾
- N 6410 - acrylic clear 8 mm
- N 6455 - acrylic smoked 5 mm
- N 6460 - acrylic smoked 8 mm
- N 6504 - polycarbonate clear 4 mm
- N 6505 - polycarbonate clear 5 mm
- N 6510 - polycarbonate clear 8 mm
- N 6554 - polycarbonate smoked 4 mm
- N 6555 - polycarbonate smoked 5 mm
- N 6560 - polycarbonate smoked 8 mm
- N 6602 - aluminium anod. 2 mm⁷⁾
- N 6603 - aluminium non anod. 4 mm⁸⁾

- N 6605 - aluminium non anod. 5 mm
- N 6610 - aluminium non anod. 8 mm⁸⁾
- N 6615 - aluminium non anod. 12 mm
- N 6620 - aluminium non anod. 20 mm
- N 6761 - wire mesh welded, black⁹⁾
40/40 Ø 4 mm
- N 6771 - wire mesh welded, zinc coated
40/40 Ø 4 mm

Rough size of the panels

- 1) 2650 x 2070 mm
- 2) 2850 x 2070 mm
- 3) 3050 x 1530 mm
- 4) 3050 x 1220 mm
- 5) 3050 x 1560 mm
- 6) 3050 x 2050 mm
- 7) 4000 x 1500 mm
- 8) 2000 x 1000 mm
- 9) 2000 x 1600 mm

On request : special colours, glass panels, painted or stainless steel sheet. Electronic industry : conductive panels resistant to hot solder.

Panel dimensions according to type of mounting :

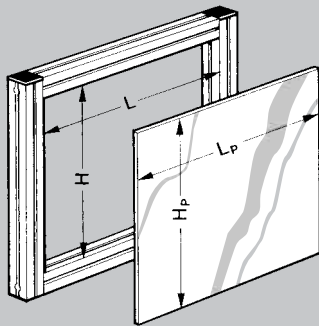

- Panel on N 1400 and N 1398
- Panel on off centre retainer N 1402
- Panel 19 mm on M8 or M6 setscrews or panel fixing pad N 1404
- Panel 8 mm in slot and panel 3...5 mm with N 0714
- Panel 8 mm in slot - removable, on nut at bottom of profile slot
- Panel 5...8 mm on N 0717 + N 0714

- Sliding panel 5 mm in N 0413 2-track profile
- Sliding panel 8 mm in 2 or 3-track, (N 0412 or N 0411) non removable panel
- Ditto but removable (sliding on 8 Ø spacer) - caution : min Hp ≥ 350 mm

Fixing block 1/4 turn N 1399

Wire mesh on U type profile for wire mesh - N 0724

1) when using the pad N 1345 reduce Hp 2 mm.

Hp ^{±1}	Lp ^{±1}
H - 2	L - 2
H - 5	L - 5
H - 1	L - 1
H + 27 ¹⁾	L + 27
H + 10	
H - 6	L - 6
H - 11	
H - 11 ¹⁾	
H - 24 ¹⁾	
H - 12	L - 12
H + 24	L + 24

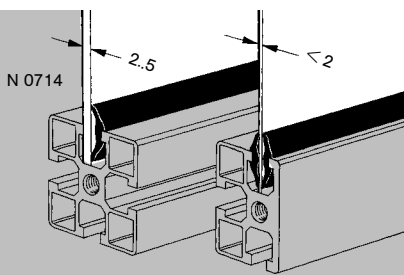

Mounting strip - N 0714, to hold plates and glasses 2 to 5 mm thick in position inside the slot (for plates under 2 mm use 2 strips!).

Material : black nitrile rubber, available in 50 m rolls. Lubricated with paraffin oil mix.

Important! To be inserted after mounting the panels. Cut to length without stretching!

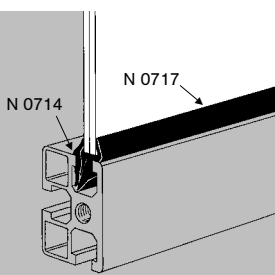
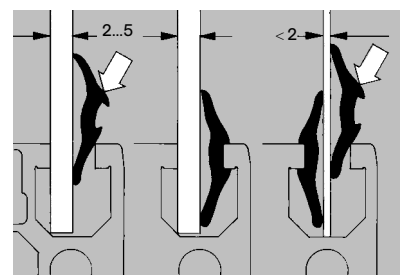

Mounting profile - N 0717

allows assembly and disassembly of glass panels and other panels from 5 to 8 mm inside existing frames without dismantling the frames.

Material : black nitrile rubber. Lubricated with paraffin oil mix.

Important : the mounting profile N 0717 has always to be combined with a mounting tape N 0714 of the same length which has to be ordered separately.

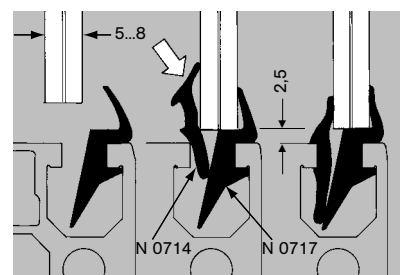

N 0724

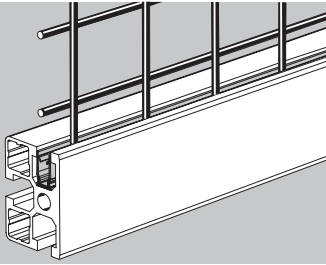

U type profile for wire mesh - N 0724 : for fixing wire mesh \varnothing 3...4 in the slots of NORCAN profiles.

Material: grey PP.
Length: 3m.

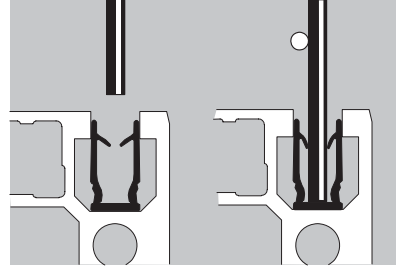

N 0710

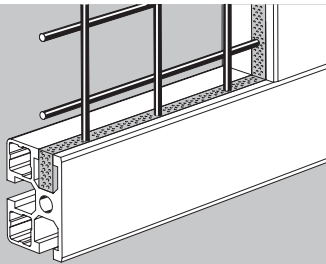

Sealing strip PE foam for wire mesh - N 0710 : for dust proof sealing of wire mesh protections.

Material: PE foam (closed cellular construction).

Important : first mount the PE strip on the wire mesh, then position the wire mesh inside the slot and finally push down the sealing strip to its final position.

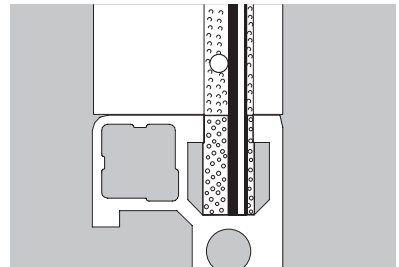

N 1399

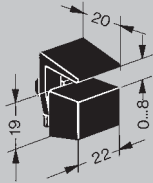

Panel fixing block 1/4 turn - N 1399 : for 1...8 mm thick panels on the slotted profile side. Assembly without tools, dismantling with a small screw-driver or similar.

Material : black polyamide.

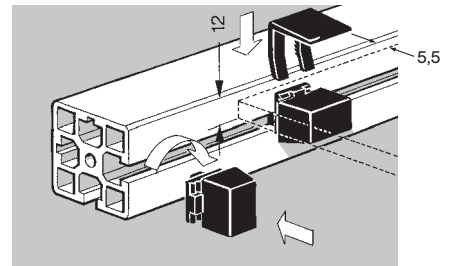

N 1398

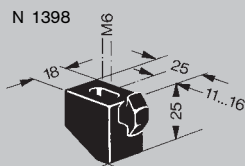

Fixing block 1/4 turn - N 1398 : for fixing 1...5 mm thick panels on the slotted sides of profiles N 0163, N 0164, N 0195, N 0264 and 1...19 mm panels on the slotted side of any other NORCAN profiles

Material : black polyamide.

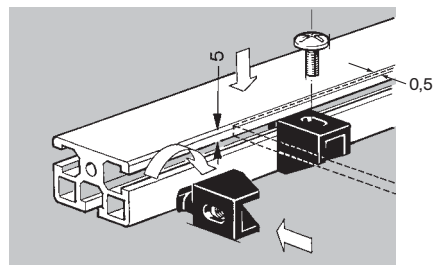

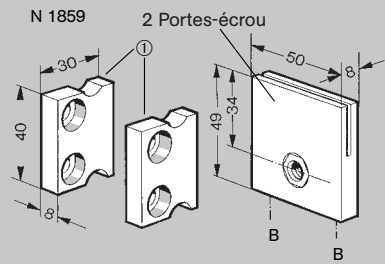

Kit 2 for quick removal of panels - N 1859: with screws and nuts and 2 door stops with nuts. Same application as N 1860. The parts ① are prevented from rotation by two fixing screws and unlike N 1860 can be fitted without resting on another piece.

Important: after adjustment, on first fitting the locking screws at "B" must be fully tightened.

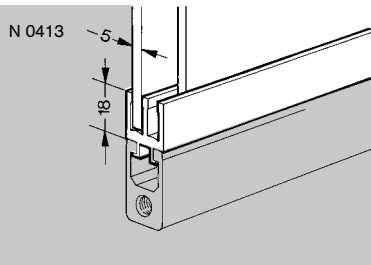
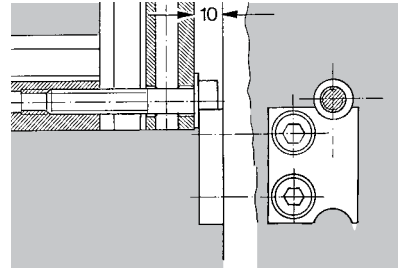

Guide profile 2 tracks 5 mm N 0413

Material: anodised aluminium alloy.

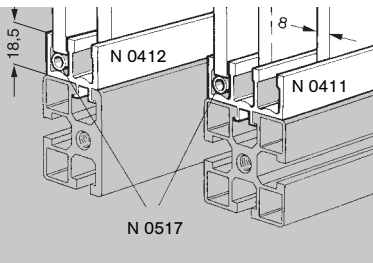
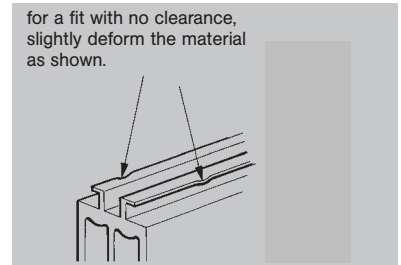

Guide profile 2 tracks 8 mm - N 0412
Guide profile 3 tracks 8 mm - N 0411

For 8 mm panels. Inserting $\varnothing 8$ tubing N 0517 in the lower slots allows removal of glass higher than 350 mm without dismantling the frame.

Material: anodised aluminium alloy.

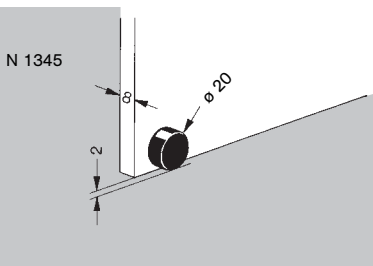
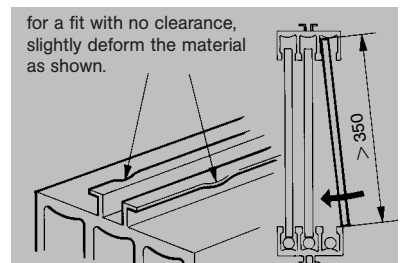

Pad for 8 mm sliding doors - N 1345:

self lubricating. To reduce friction and to avoid jamming of sliding doors.

Material: HD-polyethylene.

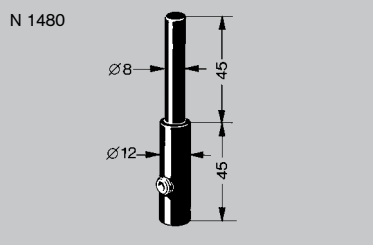
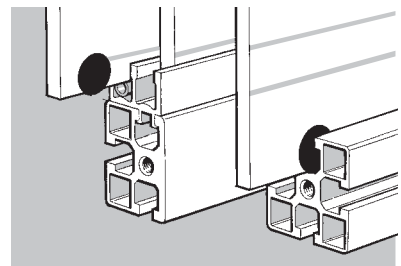

Guiding Finger - N 1480: For easily removable sliding frames. Can be pulled back after loosening the locking screw

Material: polyamide, black. Screw zinc plated steel.

Application examples see p. 80.

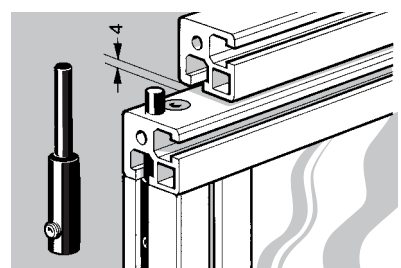

N 1348

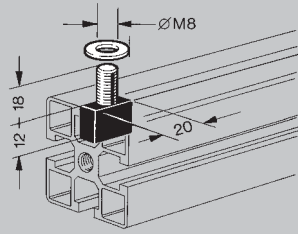

Guiding pad on M8 screw - N 1348

For sliding and folding doors.

Material : polyethylene black.

Important! fix the screw with thread sealant.

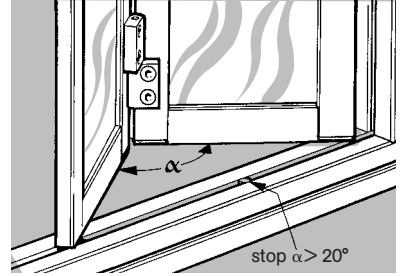

N 0820

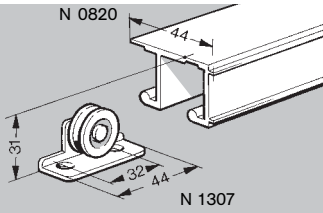

Double door rail - N 0820

Roller for double door rail - N 1307

For sliding doors - maximum load 100 N per roller.

Material : rail : plain aluminium, roller : zinc plated steel.

Lower guide : guiding finger N 1480 in guide profile 3 tracks N 0411 (page 45).

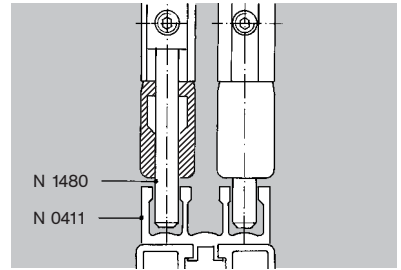
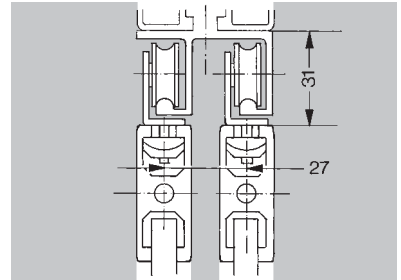

N 1484
(N 1483)

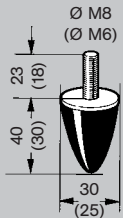

N 1485

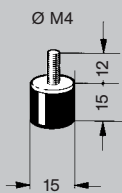

Buffer, conical ø 25 x 30 - N 1483

Buffer, conical ø 30 x 40 - N 1484

Buffer, cylindrical ø 15 x 15 - N 1485

For stop devices on sliding doors and linear guidance carriages.

Material: SBR rubber, 60/65 Shore A, screw bichromated.

N 1465

N 1464

N 1468

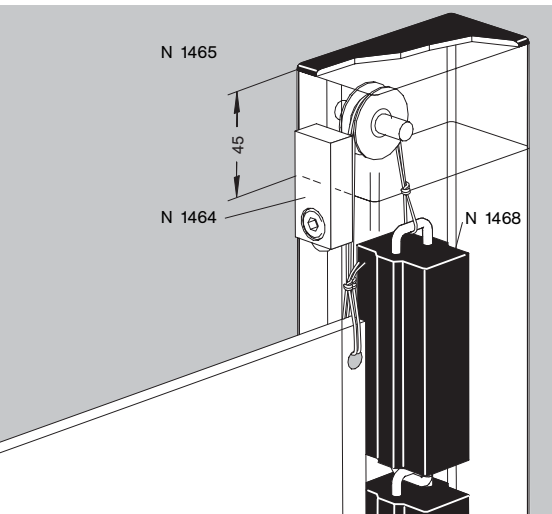

Counterbalance for vertical sliding panels : consists of a length of 45x90 mm NORCAN profile equipped with a pulley and suspended counterweight. For low cost construction or sliding doors made of polycarbonate 8 mm thick.

N 1465 : Roller box, complete with end plate and cord. Please note two sets are required per door.

Important! please note that 2 sets are required per door!

N 1468 : 1 kg - counterweight with hooks (Up to 8 counterweights can be joined together).

Material: Lead, black epoxy/polyester coating.

N 1464 : Roller box end stop.

For heavier loads contact our technical department.

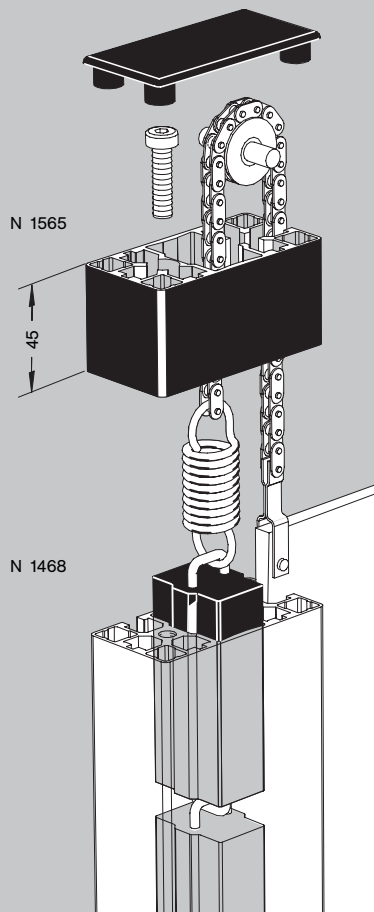

Counterbalance with chain - N1565 : for vertical sliding panels. Consists of a length of 45x90mm NORCAN profile equipped with a pulley and 2m of 8mm chain with, on one side, a stainless steel fixing for 8mm panels or a guide profile N 1347 and, on the other side a spring for attaching up to 8 counterweights of 1kg N1468. **Important** : please note that 2 sets are required per door!

Counterweight - N1468 1kg counterweight with 2 hooks (up to 8 counterweights can be joined together).
Material: Lead, black epoxy/polyester coating.

End stops : see "Buffers" p46.

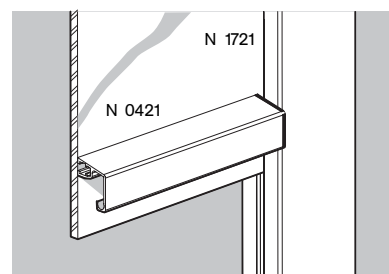
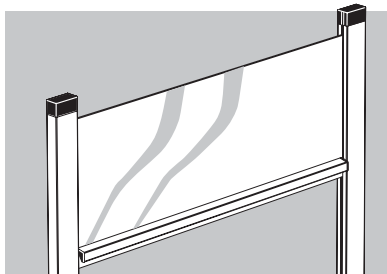
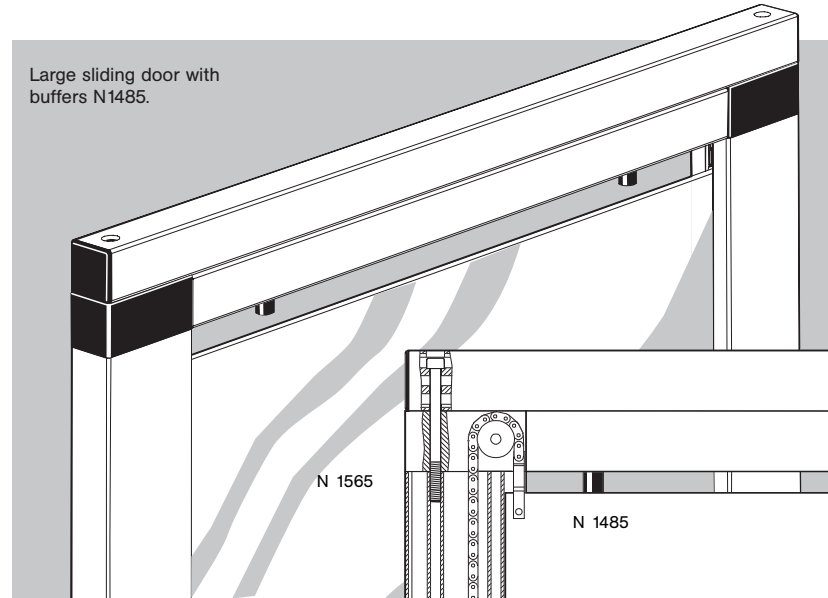

Large sliding doors may be stiffened with profiles for handles N0421 (end caps N1721).

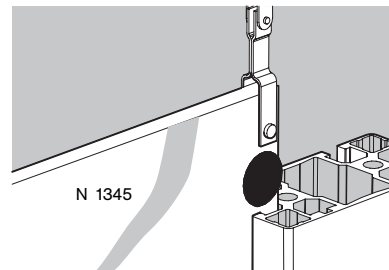
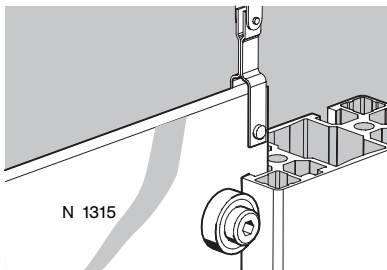

To avoid the crabbing or jamming of sliding panels, especially if the ratio of height to width is smaller than 0,7 the panel should be equipped with ball bearings N1305 or pads for sliding doors N1345 to assure a smooth linear guidance.

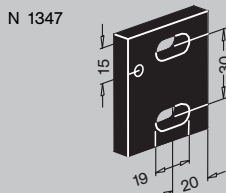

Guide profile for sliding doors - N1347 : with 2M8x20 screws and 2 washers, for vertical sliding doors framed in NORCAN profiles.

Material: black HDPE.

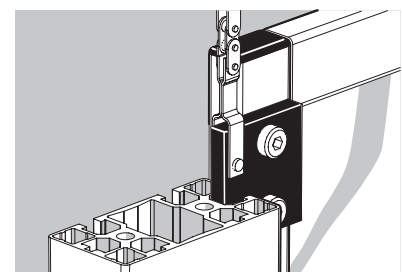

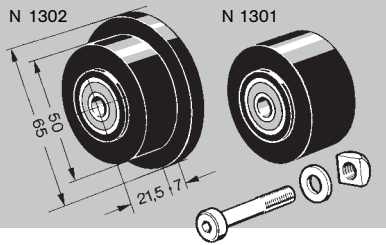

Shouldered Linear Guide Roller - N 1302 : Roller in PA 6.6 on two bearings and secured by central bolt M8.

Linear Guide Roller - N 1301 : Roller in PA 6.6 on two bearings and secured by central bolt M8.

Maximum radial load < 400 N/security factor
 Maximum speed < 100 m/min
 Speed x load ≤ 6000 Nm/min

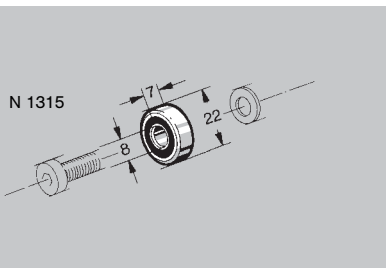
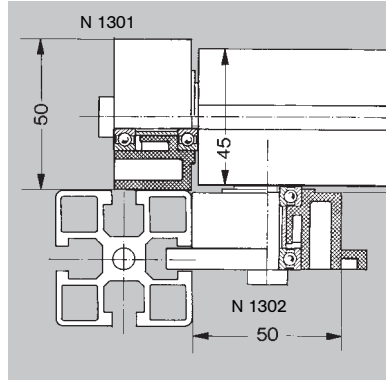
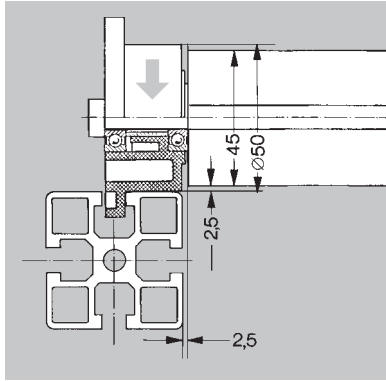

Ball Bearing - N 1315 : with 1 M8x25 screw, 1M8SC nut and 1 washer M8 Ø 16. for linear guides, can be fitted using M8 screws on all NORCAN profiles. Maximum radial load: 100N.

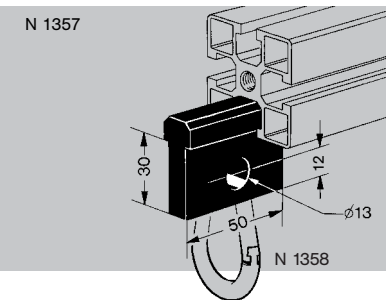
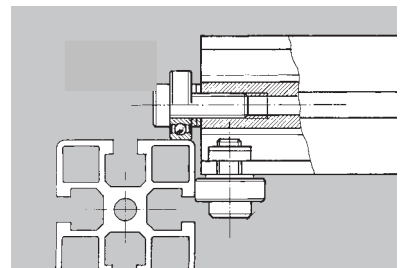

Guide profile - N 1357 : To hang objects, for example electric or pneumatic tools on a workstation.

Material : black polyethylene.

Snap hook - N 1358 : Length 60 mm, Ø steel 6 mm.

Material : steel, zinc-coated.

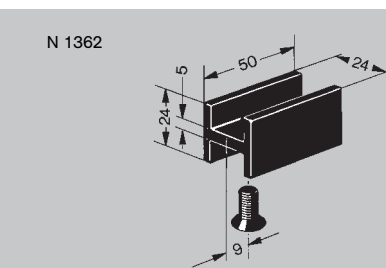

H-section guide block - N 1362 : with 1 M8x16F screw and 1M8SC nut. For double sliding doors made of 18x31,5 mm NORCAN profile sliding on the 45 mm slotted side of any NORCAN profile.

Material : HD polyethylene, black.

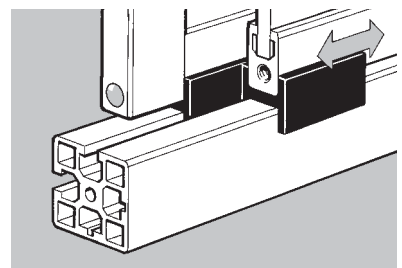

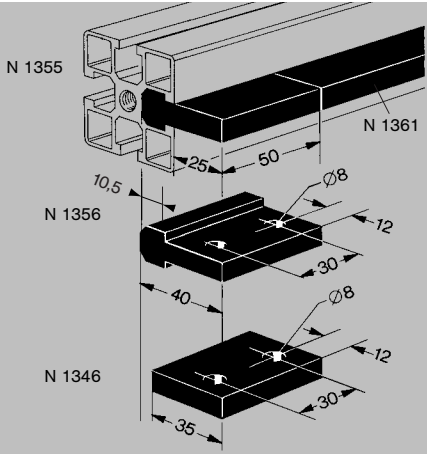

Guide profiles in high density polyethylene, black. To make guide rails using the slot in NORCAN profiles.

N 1361 : Length 500 mm, mainly to produce special parts.
N 1355 : As N 1361, but length 50 mm.

N 1356 : with 2 M8x20 screws, 2 M9SC nuts and 2 washers M8 $\varnothing 16$. For linear guides, fixed side, and sliding windows (see p. 80).

N 1346 : with 2 M8x20 screws and 2 washers M8 $\varnothing 16$. For linear guides, free side, and sliding windows (see p. 80).

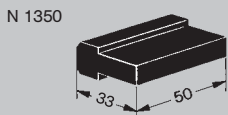
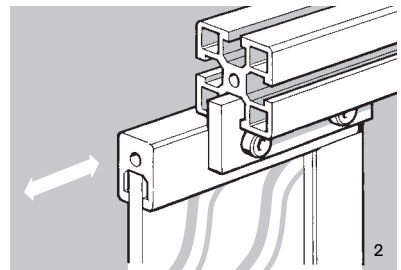
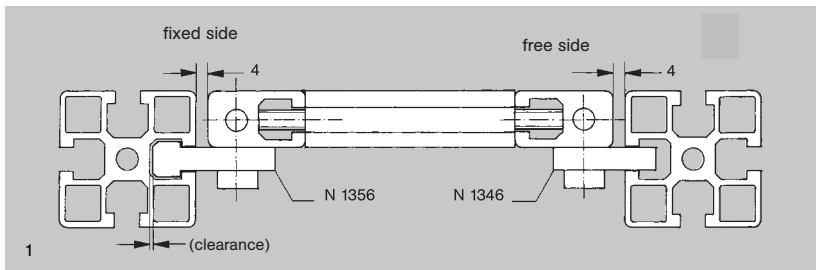

Guide profile 1350 : For linear guides, must be locked with a screw through the profile.

N 1351 : As N 1350, but length 500 mm.

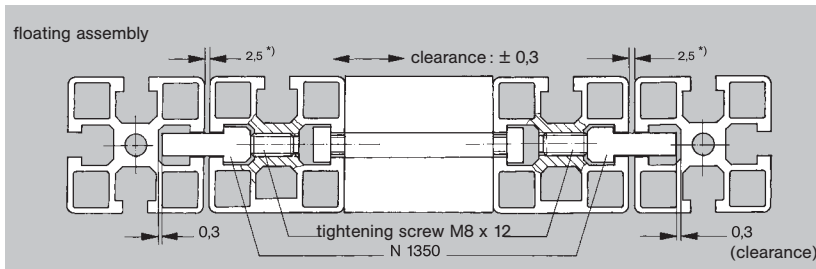

*) 3,5 mm for outer side profile
 N 0115, N 0116, N 0117, N 0268

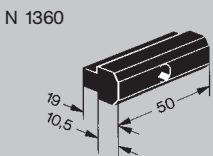

N 1360 : with 1M8x25 screw. For sliding windows.

Important : Do not tighten the M6 fixing screw, use thread sealant.

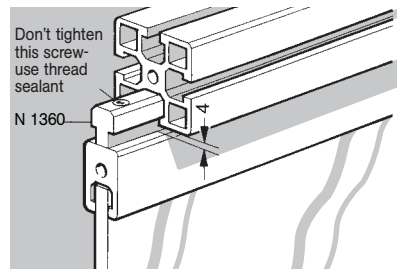

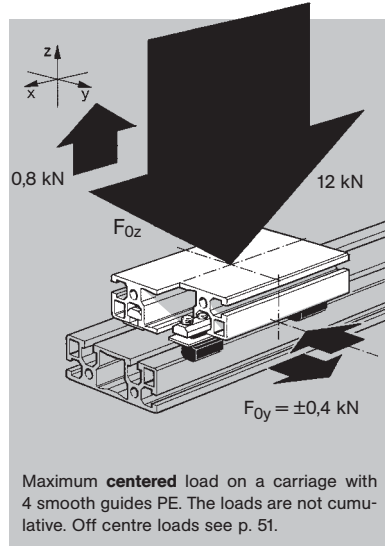
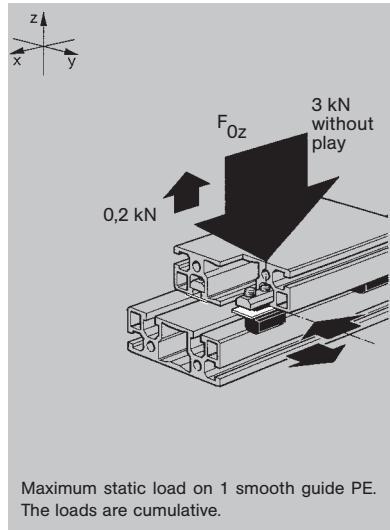

Smooth guides PE (p. 51): economical and robust linear guidance, particularly shock resistant in the -z direction (3kN). Ideal for combinations with trapezoidal screw drives.

Life: limited by the wear of the most loaded guide – see p.51.

Lubrication: without

Coefficient of friction: $\approx 0,1$.

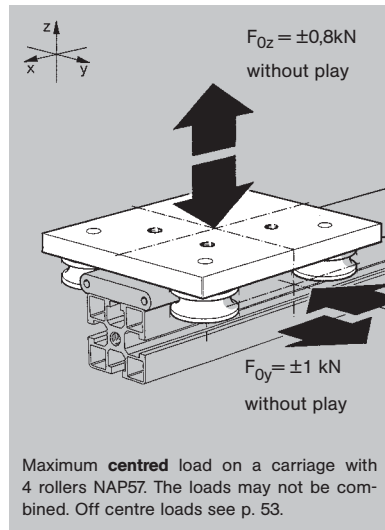
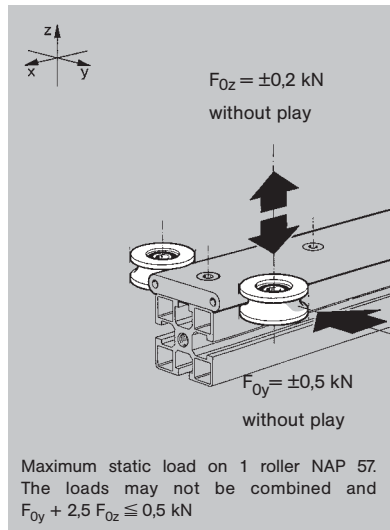

Linear guidance systems on polyester rollers NAP57 (p. 52): guidance without play, smooth and silent in operation running on anodized aluminium rails.

Life: see p.53.

Play: adjustable without play.

Lubrication: without.

Speed: dependant on the load, up to 5m/s.

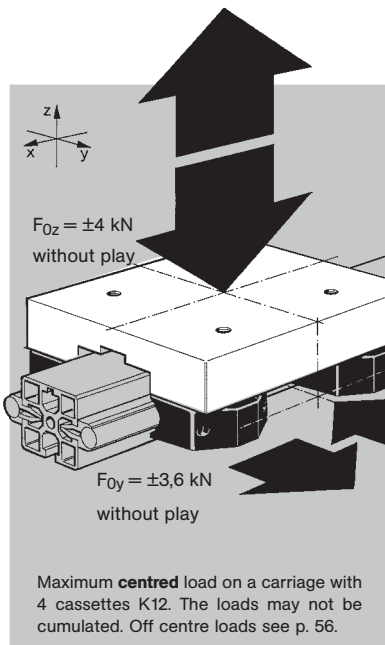
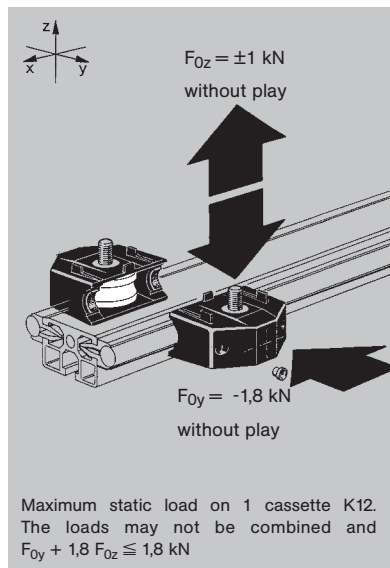

Linear guidance system on cassettes with steel rollers K12 (p. 54): rigid guidance without play on hardened steel rails.

Life: see p.56.

Play: adjustable without play.

Lubrication: assured by incorporated felt type scraping seals – to be re-oiled regularly with VG220 type oil.

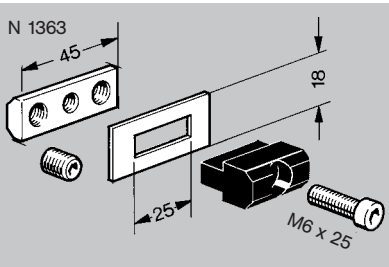

Smooth guide - N 1363: For robust and particularly shock resistant linear guidance systems. Ideal for combinations with trapezoidal screw drives. For clearance free linear guides utilise the types "NAP 57" (p. 52), "K12" (p. 54) and "LF" (p. 57).

Important! To adjust the clearance by means of the M6x20 screw, use at least one screw adjusting bore per slot of the guidance profile (see picture below). The tight antivibration thread in the triple nut prevents the M6x20 screw from loosening.

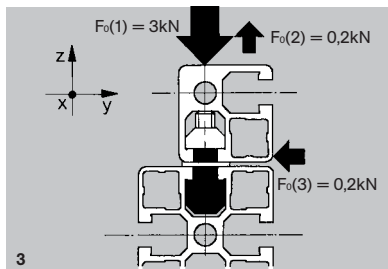
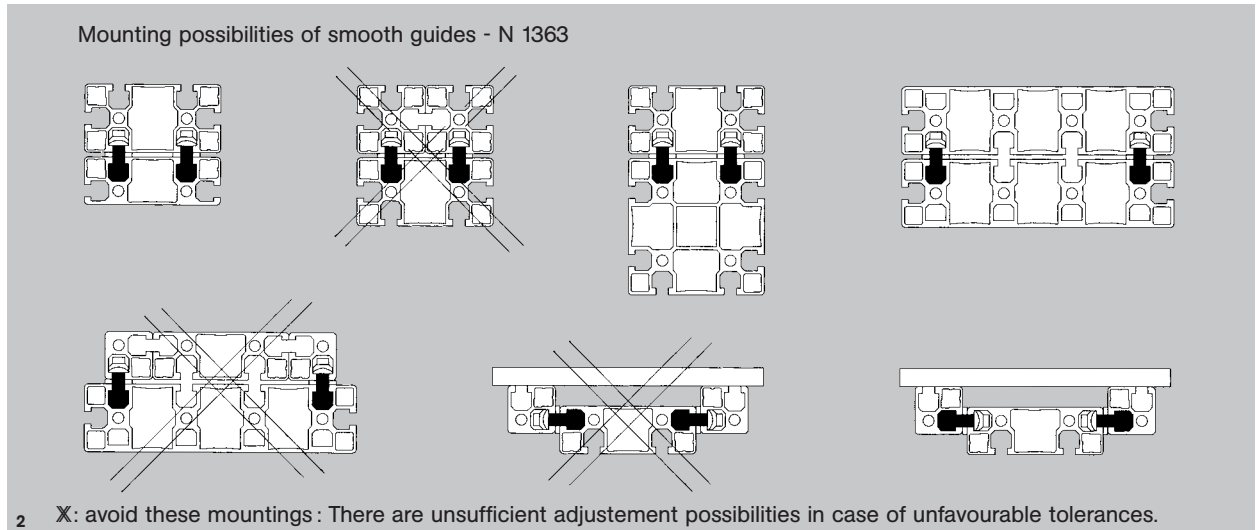
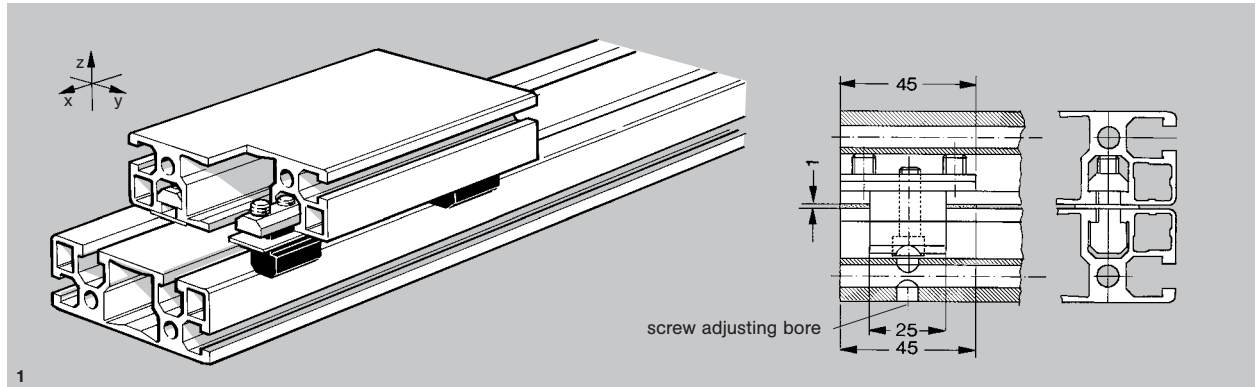

Technical specifications :

Material: Polyethylene black/clear.

Coefficients of friction : $\mu \approx 0,08$; $\mu_0 \approx 0,12$ for $F_0(1)$ after wearing in.

Static loads : see fig. 3, the indicated values may be cumulated.

Life: during a series of tests without lubrication under a closed housing we measured a wear of $\approx 0,1$ mm/1000 km under a load of 0,6 (0,9) N/mm² at a speed of 1,4 m/s. The circular anodised test track did not show any wear.

This corresponds roughly to load $F_0(1) \approx F_0(2) \approx 20$ N and $F_0(3) \approx 200$ N.

Play : adjustable in the z axis, $\approx 0,4$ mm in the y axis.

Assembly:

1. Position the triple nuts in the slots of the carriage and tighten the M8 grub screws.
2. Assemble the clear PE-plate and the black PE guide profile and leave about 1 mm clearance under the M6x20 screw.
3. Slide the carriage into the slots of the aluminium guidance profile.
4. Adjust the clearance by passing a key through the screw adjusting bores.

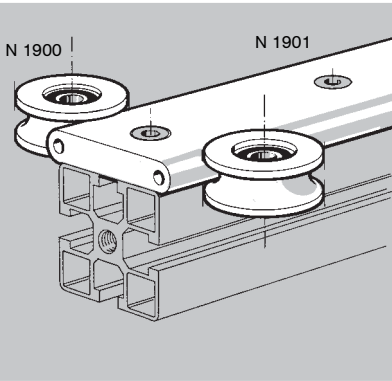

The NAP linear guides consist of an anodised aluminium alloy rail and a 2 or 4 wheeled carriage. Smooth and silent in use, the rollers on shielded ball bearings can be fitted to plates or directly to the NORCAN profiles.

Rail NAP 57 - N 1901 : In plain anodised aluminium alloy. Length according to customer specification, maximum length 6 m, distance between drillings 90 mm. Supplied without screws and nuts.

Polyester roller NAP 57 - N 1900 : without shaft on ball bearing.

Polyester roller NAP 57 - N 1903 : with concentric shaft on ball bearing.

Polyester roller NAP 57 - N 1904 : with eccentric shaft on ball bearing.

Stop for NAP 57 - N 1908 : with 2 screws M6x20: For fixing on the end of the rail N 1901. Material: anodised aluminium alloy with rubber buffers.

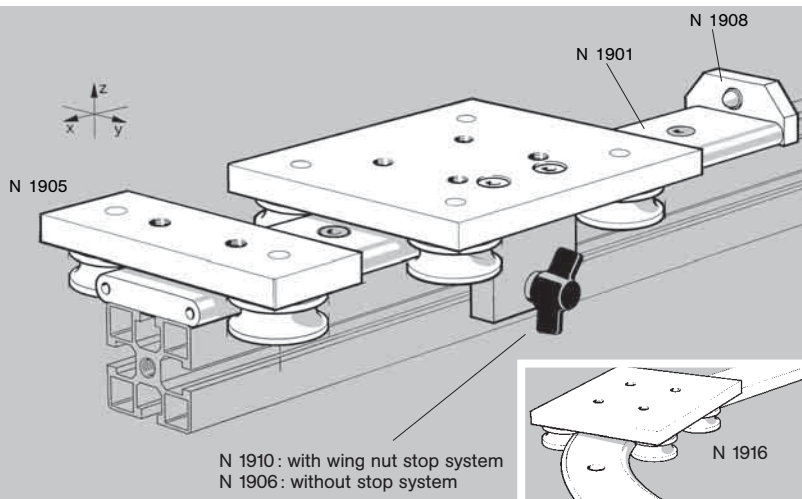

NAP 57 with 2 rollers - N 1905

2 - Wheeled carriage, one adjustable by eccentric shaft.

NAP 57 with 4 rollers - N 1906

4 - Wheeled carriage, two adjustable by eccentric shaft.

NAP 57 with 4 rollers with stop - N 1910

Free play adjustment :

Even through the N 1904 pulleys are eccentric to allow take up of free play, the carriages are not intended for use under preload.

Carriage NAP57 with 4 rollers for curved rails - N 1916 : for all applications with curved rails (minimum radius: 300 mm) contact our technical department.

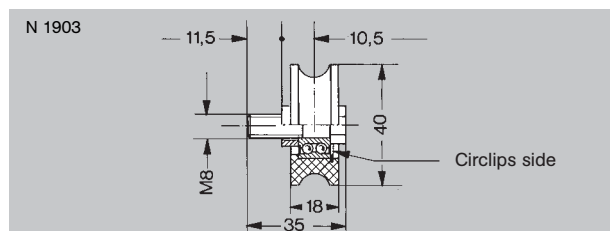
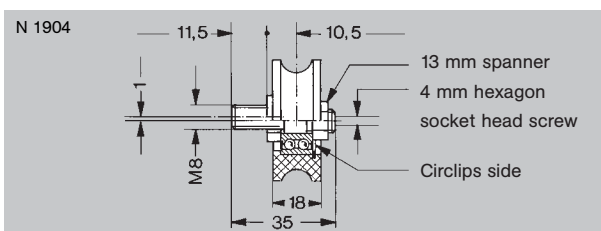
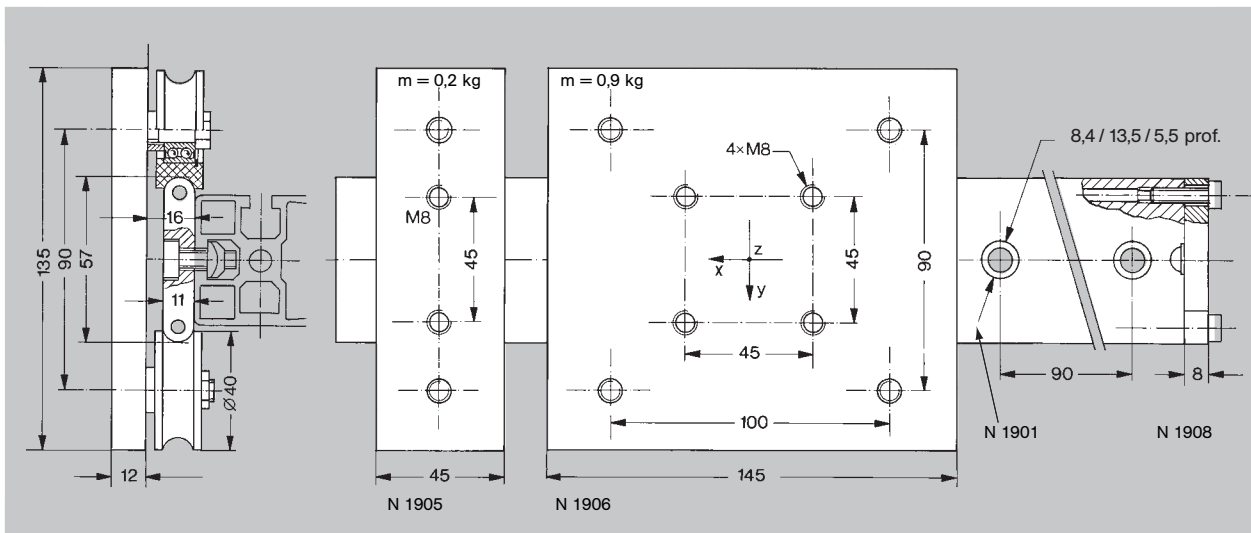

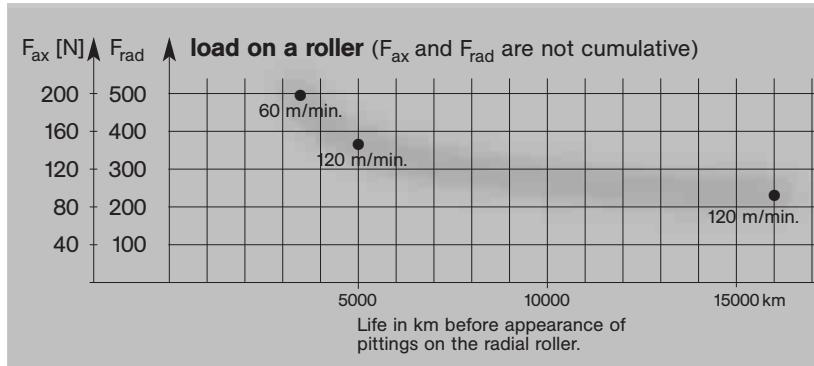

Life and allowable loads : The table opposite represents the results of a series of tests. These tests were undertaken without lubrication under a closed housing

The loads F_{ax} and F_{rad} are not cumulative. For instance an axial force $F_{ax} = 40$ N will cause an equivalent wear as a radial force of $F_{rad} = 100$ N. In general :

$$F_{rad \text{ equivalent}} \approx 2,5 F_{ax} + F_{rad}$$

The test rail did not show any wear after 10^8 cycles.

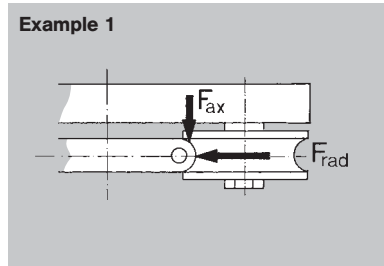
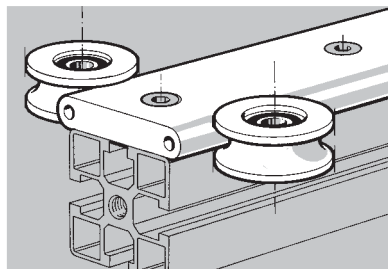

Example 1 : a roller is loaded with an axial force $F_{ax} = 60$ N and a radial force of $F_{rad} = 100$ N at a speed of 120 m/min.

The equivalent radial force :

$$F_{rad \text{ equivalent}} \approx 2,5 \cdot 60 \text{ N} + 100 \text{ N} = 250 \text{ N}$$

For this loading the test rollers achieved a life of 16000 km.

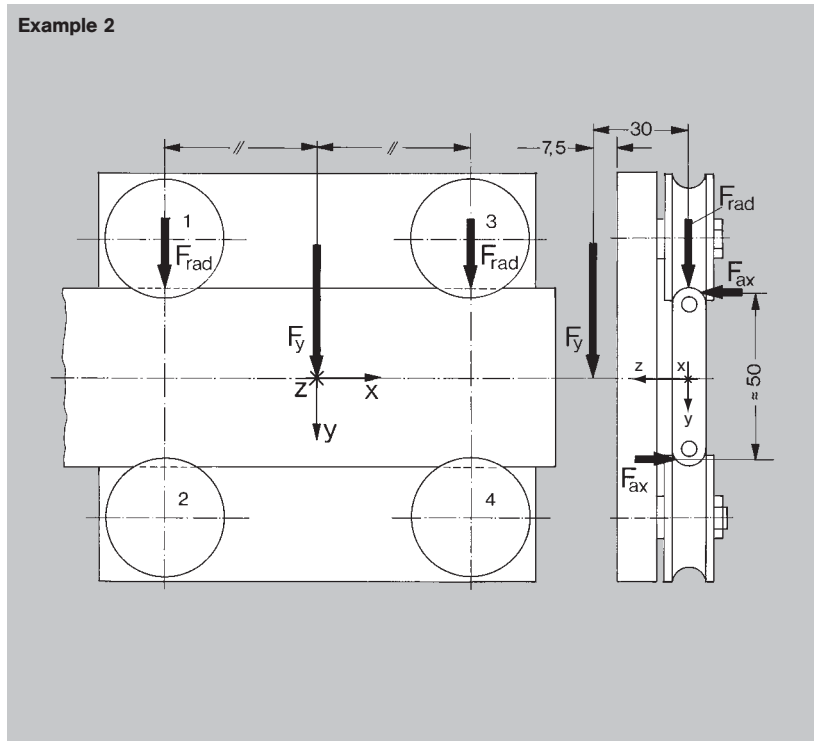

Example 2 : For the carriage opposite there is a static force, $F_y = 240$ N acting on a point 7,5 mm above the centre of the carriage, $v = 2$ m/s.

Radial force : The load F_y will act equally on roller 1 and 3

$$F_y = F_{rad 1} + F_{rad 3} = 2 F_{rad 1}$$

$$F_{rad 1} = 1/2 F_y = 1/2 \cdot 240 \text{ N} = 120 \text{ N}$$

Axial force : At the same time F_y results in a moment, $M_x = 30 \text{ mm} \cdot F_y$ which causes the following axial loading on the rollers :

$$F_{ax 1} = F_{ax 2} = 1/2 F_y \cdot \frac{30 \text{ mm}}{50 \text{ mm}} = 1/2 \cdot 240 \text{ N} \cdot \frac{30 \text{ mm}}{50 \text{ mm}} = 72 \text{ N}$$

The most loaded rollers are thus rollers 1 and 3, which see an axial force of $F_{ax} = 72$ N together with a radial force of $F_{rad} = 120$ N.

The equivalent loading is :

$$F_{rad \text{ equivalent}} \approx 2,5 F_{ax} + F_{rad} = 2,5 \cdot 72 \text{ N} + 120 \text{ N} = 300 \text{ N}$$

Interpolation from the test result the life would be approximately 7000 km.

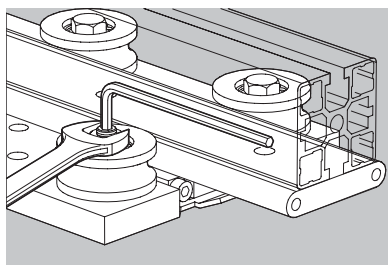

Assembly : First mount the rollers with eccentric shafts. Screw in that shaft completely whilst holding the nut with a #13 spanner. Then undo the shaft about a half turn into the position "maximum play". Tighten the nut very slightly. Mount and tighten the rollers with concentric shafts.

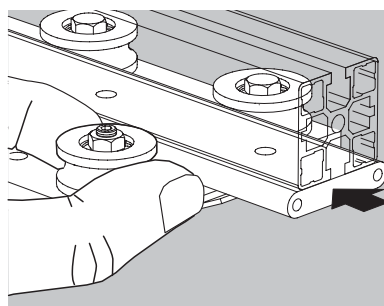

Adjusting : With a #13 flat spanner hold the nut of the roller with eccentric shaft and eliminate the play when turning the shaft with a #4 Allen wrench. Hold the Allen wrench in this position and firmly tighten the nut with the #13 flat spanner.

A correct preload is attained when the roller can just be turned by hand, the carriage being blocked.

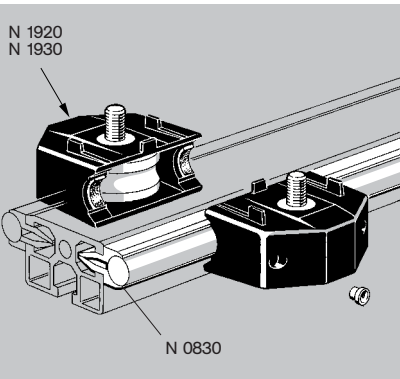

The linear guidance system K12 consists of steel guide rails hardened to 60 HRC fitted into the slot of NORCAN profiles and steel rollers on shielded (zz) bearings individually protected and lubricated by cassettes of PA compound. The lubricators allow to re-oil the felt-type scraping seals (don't use grease!).

The examples below show some basic mounting methods of K12 cassettes onto NORCAN profiles. The anti-rotation strips incorporated to allow accurate mounting can be removed easily if required.

K 12 cassette with roller and concentric shaft - N 1920: with M8 SC nut. C_w (100 000 m) = 8,3 kN; P_o see "Forces" p. 42. Material: polyamide, black, with 15% glass fibre.

K 12 cassette with roller and eccentric shaft - N 1930: with M8 SC nut. C_w (100 000 m) = 8,3 kN; P_o see "Forces" p. 42. Material: polyamide, black, with 15% glass fibre. The eccentric shaft allows take up of free play (± 1 mm) however the system is not intended for use under preload.

Rail K 12 - N 0830: Consisting of a steel guide rail hardened to 60 HCR and two aluminium profiles "clip K12" to fit into the slots of NORCAN profiles. Maximum length 6 m - it is possible to connect two lengths together.

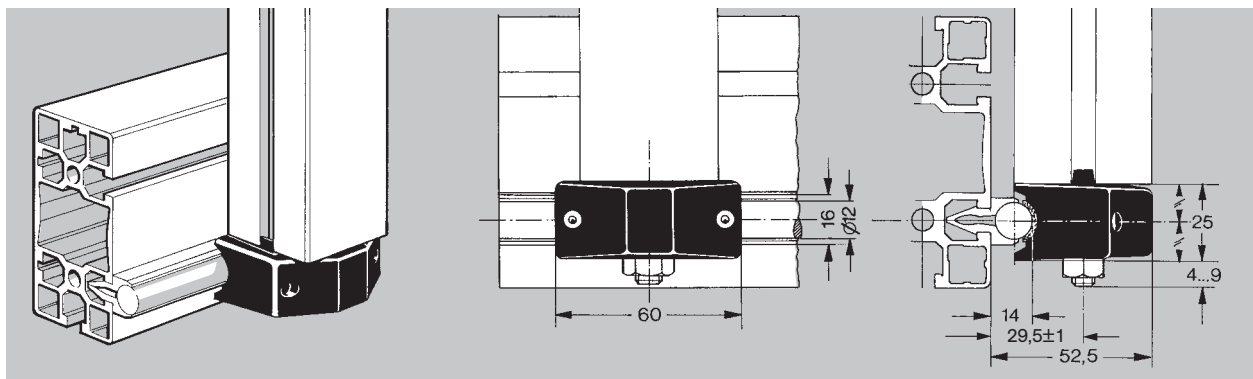
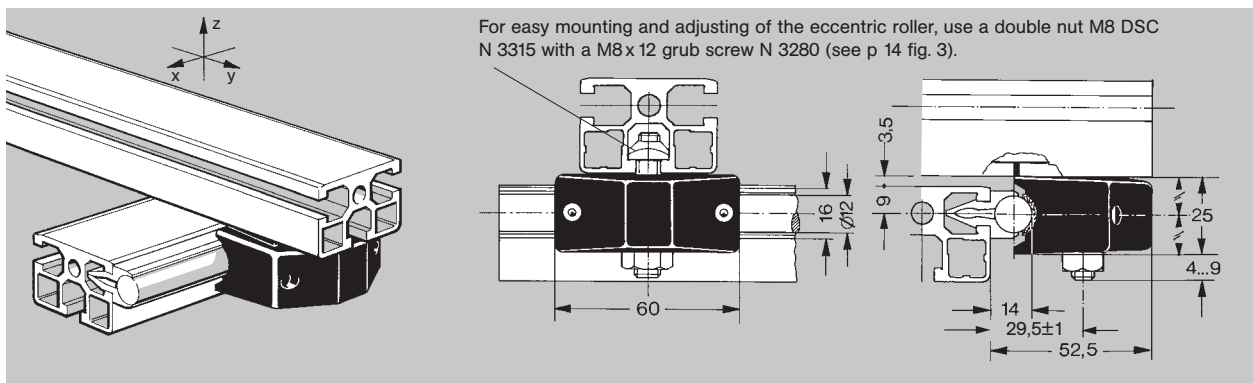
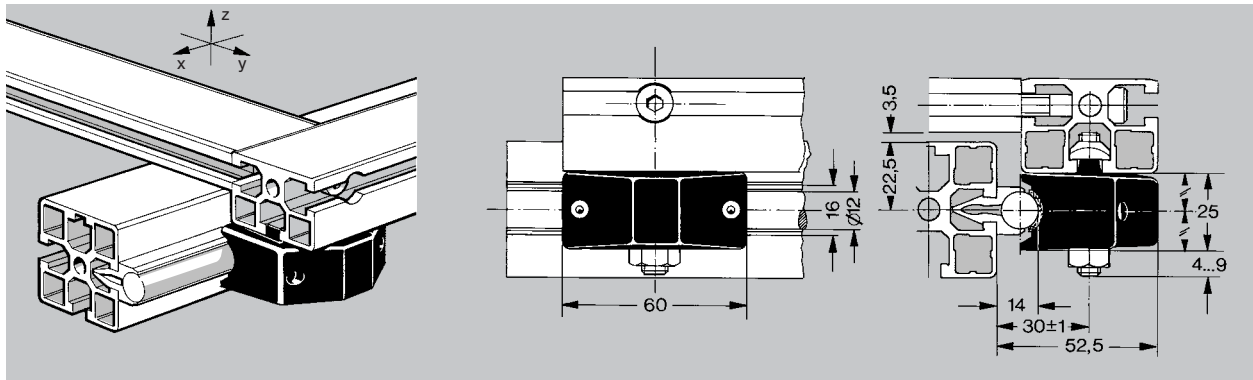

Direct mountings of K12-cassettes onto NORCAN profiles and plates. Indirect mounting with strut profile see below.

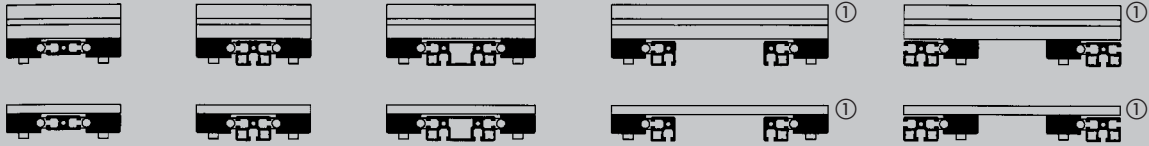

The following mountings need cassettes with eccentric shaft N 1930 on **both sides** of the rail!

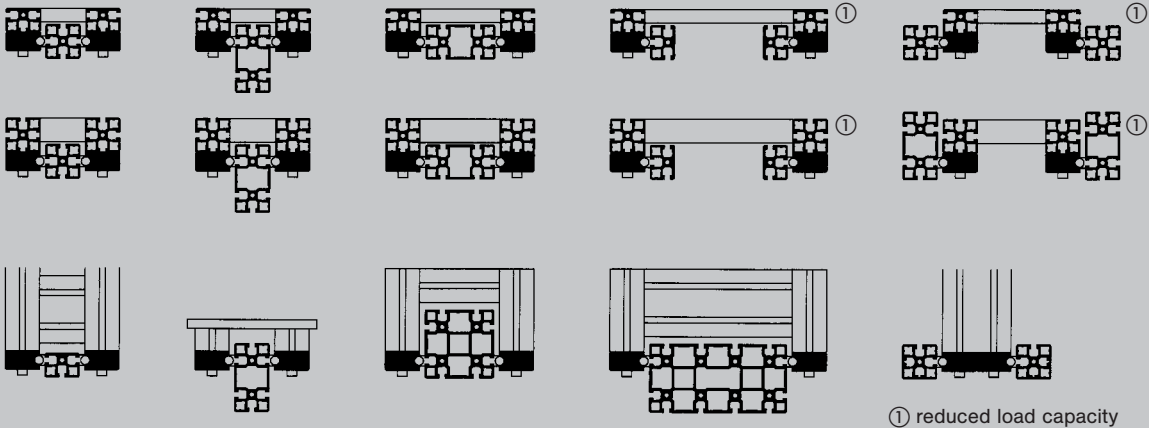

① reduced load capacity

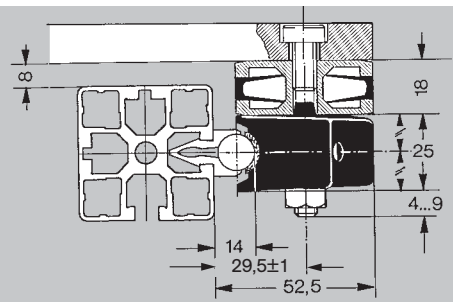
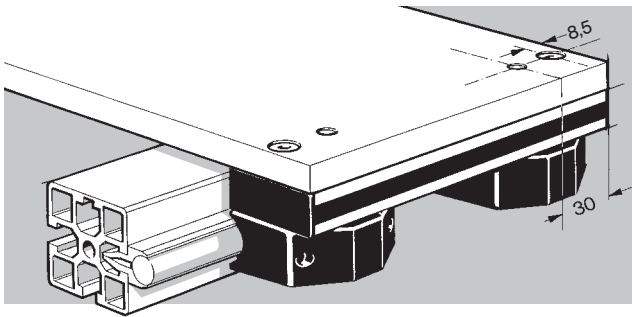
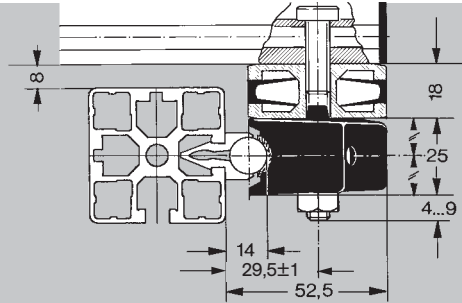
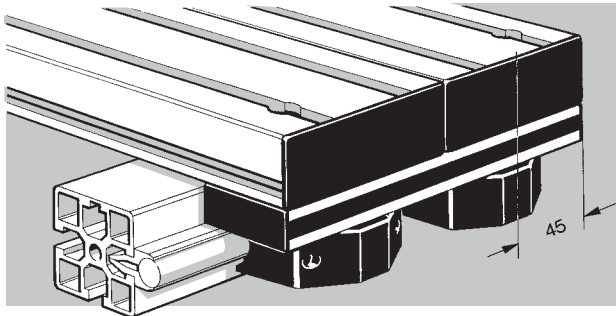

Indirect mountings of K12-cassettes with strut-profile NORCAN 18x45 mm N 0162. These mountings need cassettes with eccentric shaft N 1930 on **both sides** of the rail!

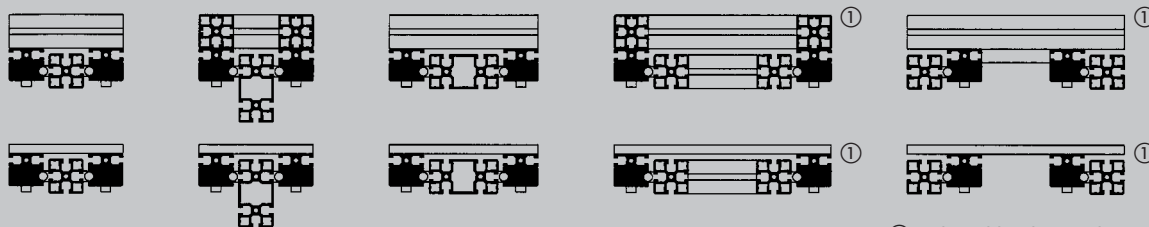

① reduced load capacity

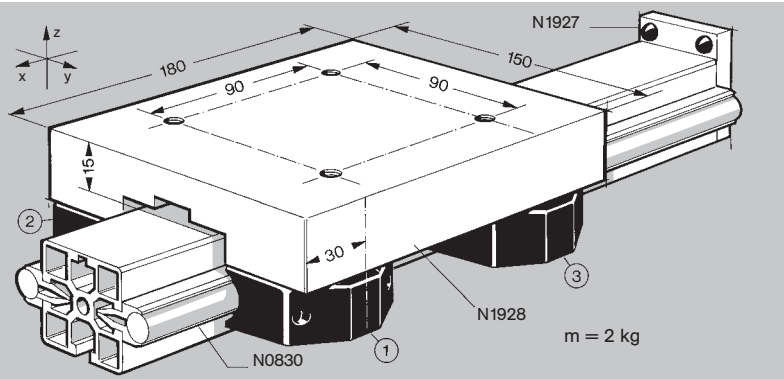

Carriage K12 with 4 cassettes N1928 carriage 150 x 180 mm with 2 concentric and 2 eccentric rollers.

Material: anodised aluminium.

Stop for K12 - N1927 with M8x20 flat head screw to fix on the end of the profile.

Material: anodised aluminium with rubber buffers.

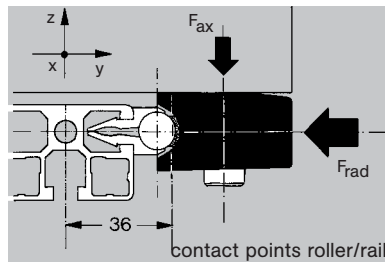

Forces: The equivalent force F_0 on a cassette whose fixing screw is tightened with 20 Nm is limited by the resistance to sliding and fatigue of the fixing screw and may be calculated averagely as follows:

$$F_0 \approx F_{rad} + 1,8 F_{ax} \leq 1,8 \text{ kN/S}$$

S = safety factor.

For heavier loads contact our technical department.

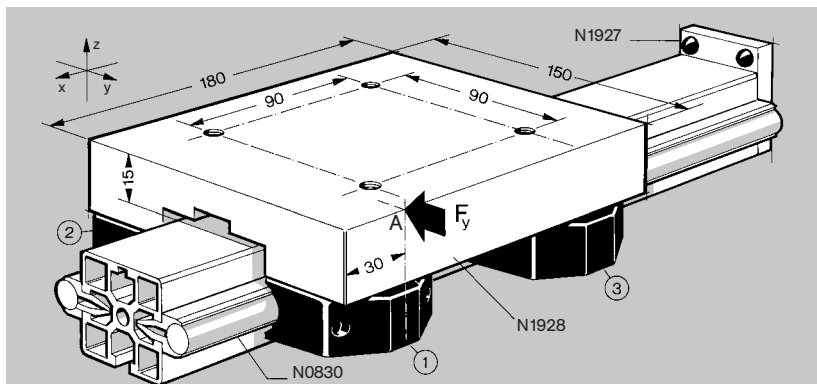

On the above carriage a constant force $F_y = 500 \text{ N}$ is acting on the point A.

Radial force: The load F_y will act only on roller ① as it is situated in the plain containing the axis of roller ① and ②. $\Rightarrow F_{rad} = 500 \text{ N}$

Axial force: At the same time, F_y results in a moment around the the x-axis

$$M_x = F_y (22,5 + 15) \text{ mm,}$$

which causes the following axial loading on each roller:

$$F_{ax} = \frac{1}{4} F_y (22,5 + 15) \text{ mm} / 36 \text{ mm} = 130 \text{ N}$$

The most loaded roller is thus roller ① which sees a radial force of $F_{rad} = 500 \text{ N}$ combined with an axial force of $F_{ax} = 130 \text{ N}$

The equivalent loading is $F_0 \approx 500 \text{ N} + 1,8 \cdot 130 \text{ N} = 734 \text{ N}$

The safety is $S = 1,8 \text{ kN} / 734 \text{ N} = 2,5$

Life: $F_{rad} \geq F_{ax} \Rightarrow P = F_{rad} + 4,2 F_{ax} = 500 \text{ N} + 4,2 \cdot 130 \text{ N} = 1046 \text{ N}$

$$L = (C_w / P)^3 = (8,3 \text{ kN} / 1046 \text{ N})^3 = 500 [10^5 \text{ m}]$$

Life: The nominal life L of a roller is calculated the same way as the life of a ball bearing and corresponds to the life time attained or surpassed by 90% of apparently equivalent bearings before appearance of the first signs of fatigue.

$$L = \left(\frac{C_w}{P}\right)^3 [100\ 000 \text{ m}]$$

C_w = equivalent load rating
 P = equivalent dynamic load

For a stroke > 100 mm, a speed < 10 m/s, a temperature of bearing and rail between -20 and +80°C, and a clean and lubricated rail P can be estimated as follows:

$$P(F_{rad} \geq F_{ax}) = F_{rad} + 4,2 F_{ax}$$

$$P(F_{rad} < F_{ax}) = 0,5 F_{rad} + 4,7 F_{ax}$$

For many applications it is sufficient to calculate the live of the most charged roller.

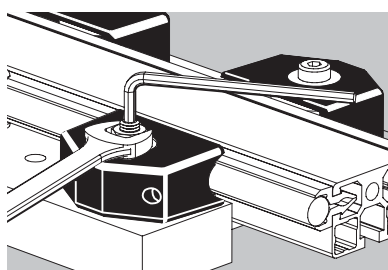

Assembly: First mount the cassettes with eccentric shaft. Screw in that shaft completely while holding the nut with a #13 spanner. Then undo the shaft about a half turn into the position "maximum play". Tighten the nut very slightly. Mount and tighten the cassettes with concentric shaft.

Adjusting: With a #13 flat spanner hold the nut of the cassettes with eccentric shaft and eliminate the play when turning the shaft with a #4 Allen wrench. Hold the Allen wrench in this position and firmly tighten the nut with the #13 flat spanner.

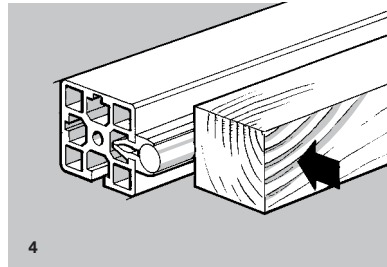
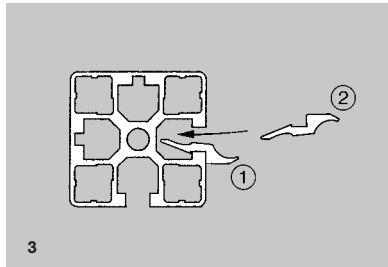

Assembly instructions :

1. Put the "clip K12" aluminium profiles into the profile slot, one after the other (fig. 3).
2. Snap-in the steel rail (fig. 4). To avoid excessive point loading use a piece of polyamide, wood or similar material of ≈ 300 mm length.

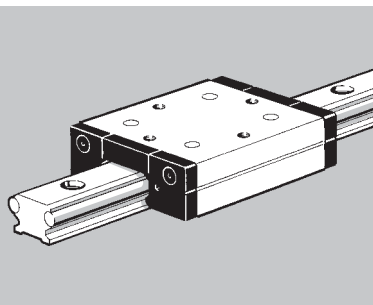

Linear guide type LF...K

Accurate, robust quality linear guide. Consisting of an aluminium rail, into which are fitted two steel guide rails hardened to 60 HRC, and a one piece carriage, totally closed, with scraper seals and integrated greasing system.

Two lateral scrapers protect the bearings from dirt projection from below.

For special guides, it is possible to combine the rails with plates fitted with a roller with scrapers, grease system, and a lateral adjustment, or simply with rollers on eccentric shafts or M8 screws.

Stainless steel version on request.

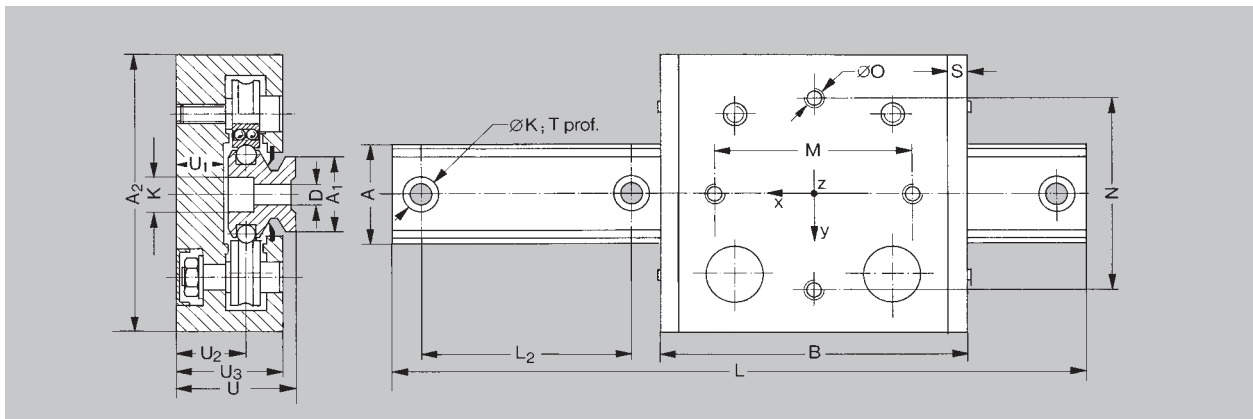

Reference		Dimensions in mm															Mass Carriage [kg]		
Carriage	Rail ²⁾	A	A ₁	A ₂	B	D	K	L _{max} ¹⁾	L ₂	M	N	O	S	T	U	U ₁	U ₂	U ₃	
LFKL 25 SF	LFS 25	25	21	65	85	5,5	10	2000	62,5	60	50	M5	5	6,5	25,0	9,0	14,4	23,5	0,3
LFKL 32 SF	LFS 32 CE	32	24	86	112	6,5	12	6000	62,5	70	59	M8	7	8	35,5	14,0	20,5	32,0	0,7
LFKL 52 SF	LFS 52 CE	52	40	130	136	11,0	19	8000	125,0	70	90	M10	10	13	54,3	19,4	29,2	46,1	1,5

Reference		Maximum loads - non cumulative - Lubrication recommended									
Carriage	Rail ²⁾	Forces [N]				Moments [Nm]					
		F _y	F _{oy}	F _z	F _{oz}	M _x	M _{ox}	M _y	M _{oy}	M _z	M _{oz}
LFKL 25 SF	LFS 25	700	700	400	660	4	6	9	15	16	16
LFKL 32 SF	LFS 32 CE	1300	1300	850	1400	11	18	26	43	39	39
LFKL 52 SF	LFS 52 CE	3500	3500	1500	2500	33	52	47	78	105	105

¹⁾ Available in length multiples of L₂ with a minimum of 2L₂. Other lengths on request.

²⁾ The rails LFS 32 and 52 CE are constructed from hollow section profiles.

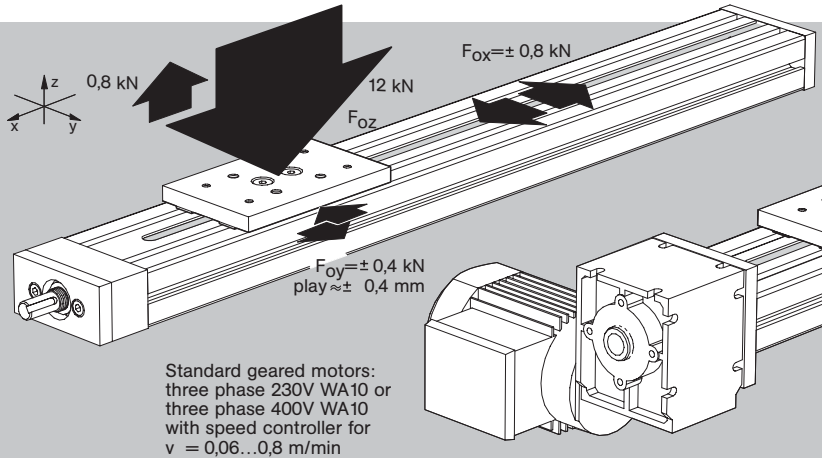

Standard geared motors:
three phase 230V WA10 or
three phase 400V WA10
with speed controller for
 $v = 0,06...0,8$ m/min

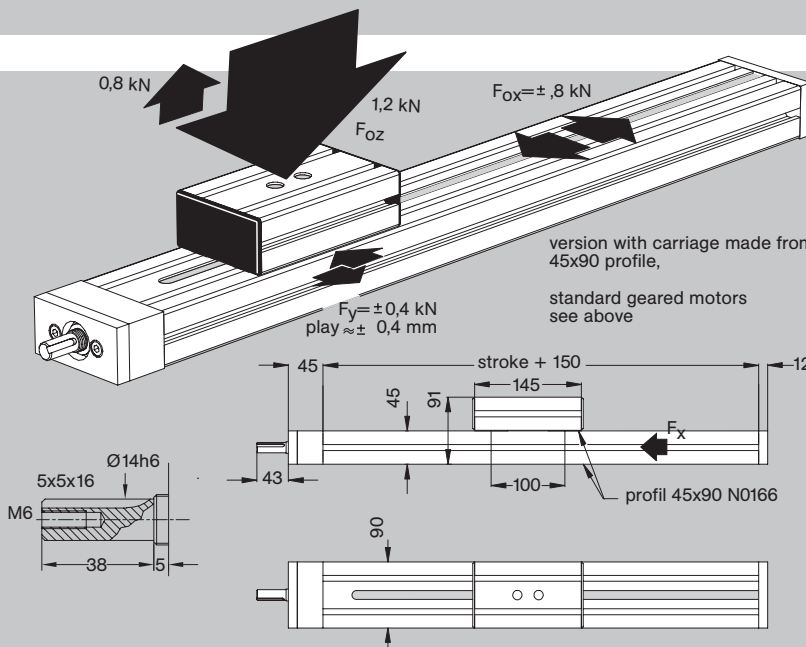
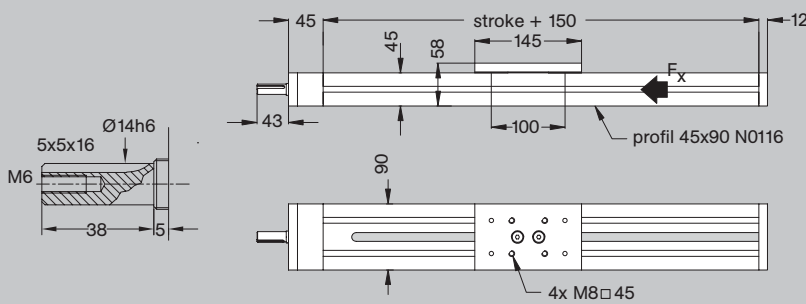
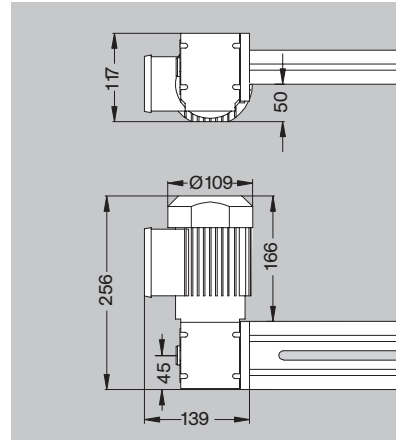

version with carriage made from
45x90 profile,
standard geared motors
see above

Linear drive and guidance module PEV: combination of a carriage on smooth guides N1363 and a Tr 16x4 trapezoidal screw incorporated in a 45x90 NORCAN profile ($T_{max} = 60^\circ C$).

Smooth and silent in use without play in the z axis.

The carriage is particularly resistant to shocks and heavy loads in the -z axis (loads from above).

Speeds: see table below.

Loads: the drawing besides shows, centred on the carriage, the static loads F_{Oy} and F_{Oz} which may be combined. For all other types of loads see p.51. F_x see table below bearing in mind that any force which is not exactly lined up with the centre of the drive screw will create a moment putting an extra load onto the rollers of the linear guide (see example p 59).

Manual drive: The high reduction ratio (pitch = 4mm) allows the movement of heavy loads. The Tr 4x16 trapezoidal screw is not reversible; therefore the PEV linear modules are practically self locking.

Motorised drive: an axial load of 800N at a speed of 0,5m/min ≈ 125 rev/min will heat the drive screw with initially $2^\circ C/min$ (maximum temperature $60^\circ C$) whereas cooling under the same conditions will take twice as much time. This shows that a drive by trapezoidal screw needs pauses for cooling. For continuous working take toothed belt drives (p. 60/61).

Lubrication: an initial lubrication of the drive screw with silicon oil will facilitate the breaking in of the nut.

Standard geared motors: three phase 230V WA10 or 400V W10 with or without speed controller for speeds from 0,06 to 0,8 m/min.

Important: The tension of the WA10... motors is preselected, so when ordering indicate whether 400V triph. (Y) or 230V triph. (Δ).

Axial load of the drive screw - the given values incorporate a safety factor of 3 against buckling of the screw.

		L= 500 mm	L= 1000 mm	L= 1500 mm
manual drive	screw under traction	830 N	830 N	830 N
	screw under compression	830 N	460 N	200 N
M = 100 tr/min	screw under traction	830 N	830 N	830 N
	screw under compression	830 N	360 N	150 N
M = 200 tr/min	screw under traction	830 N	830 N	830 N
	screw under compression	830 N	330 N	120 N
M = 300 tr/min	screw under traction	830 N	830 N	830 N
	screw under compression	830 N	300 N	70 N

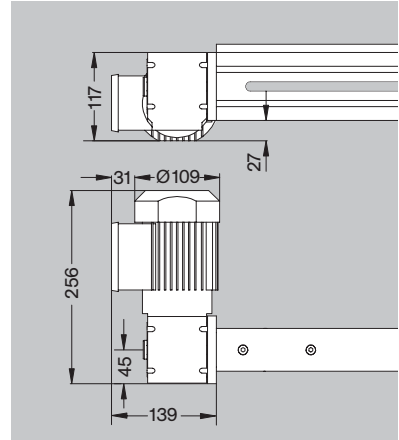
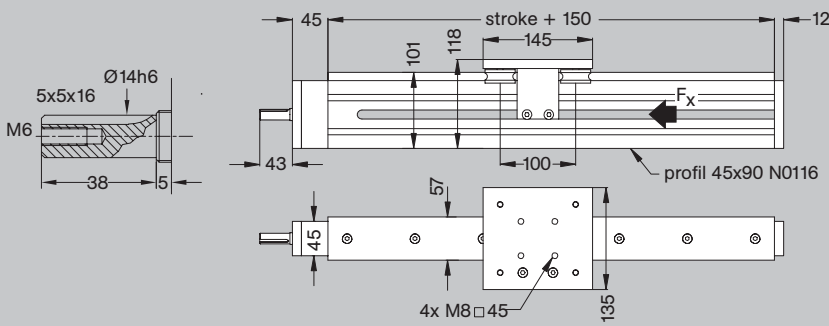
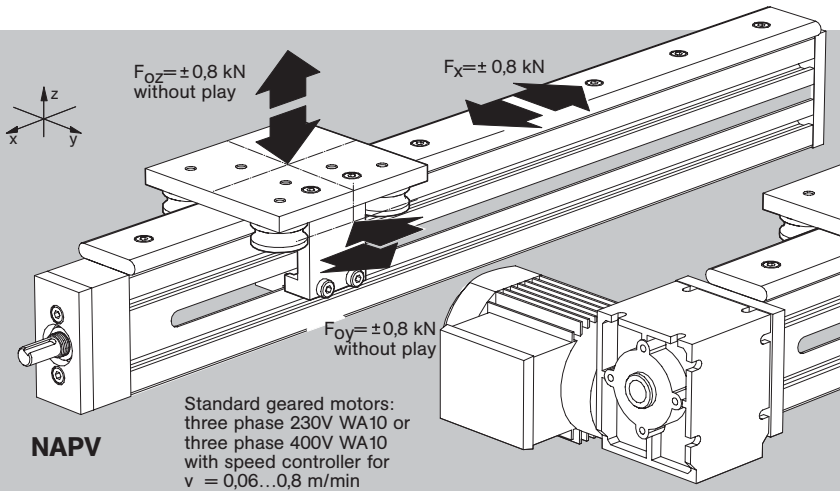

Linear drive and guidance modules NAPV and K12V: combination of the linear guide NAP57 (p.52) or K12 (p. 54) and a trapezoidal screw Tr 16x4 incorporated in a 45x90 NORCAN profile.

Smooth and silent in use, without play.

Speeds: see table below.

Loads: the drawing besides shows, centred on the carriage, the static loads F_{oy} and F_{oz} which may **not** be combined. For all other types of loads see p.53 (NAPV) and p.56 (K12V). F_x see table p.58 bearing in mind that any force which is not exactly lined up with the centre of the drive screw will create a moment putting an extra load onto the rollers of the linear guide (see example below).

Example: An axial load $F_x = 80$ N is applied 30 mm above the centre of the carriage, creating the following moment:

$$M_y = 80 \text{ N} \left(30 \text{ mm} + 118 \text{ mm} \cdot \frac{90 \text{ mm}}{2} \right)$$

$$M_z = 0$$

the resulting load on a each roller will be:

$$F_{ax} \text{ (per roller)} = 80 \text{ N} \cdot \frac{30 \text{ mm} + 73 \text{ mm}}{2 \cdot 100 \text{ mm}} = 41 \text{ N,}$$

100 mm being the distance of 2 rollers in x-direction.

Drive: see p. 58.

Lubrication: initial lubrication of the screw, with silicon oil, will facilitate the breaking in of the nut. The linear guides NAP57 do not need any lubrication. The linear guides K12 may be re-oiled with ISO-VG-220 oil if necessary.

Standard geared motors: three phase 230V WA10 or 400V W10 with or without speed controller for speeds from 0,06 to 0,8 m/min.

Important: The tension of the WA10... motors is preselected, so when ordering indicate whether 400V triph. (Y) or 230V triph. (Δ).

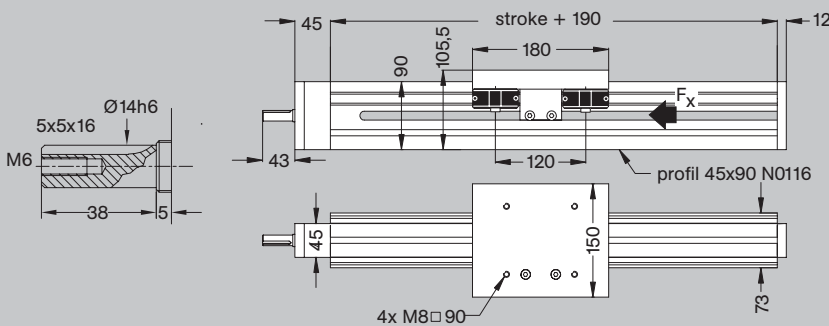
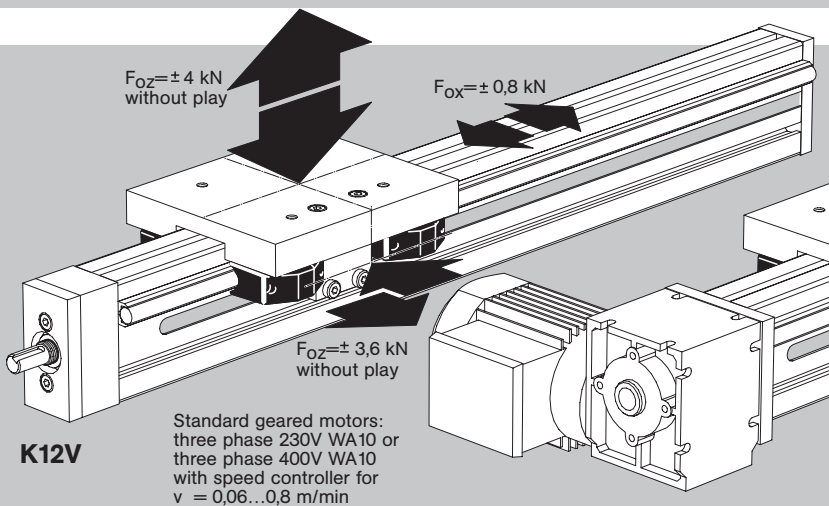

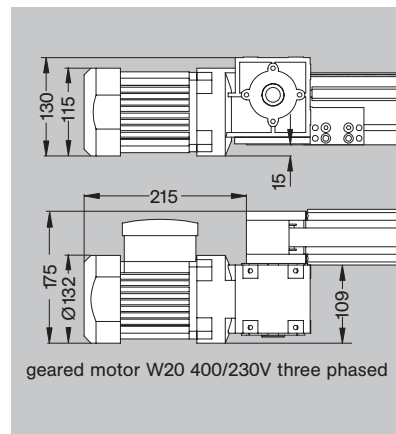
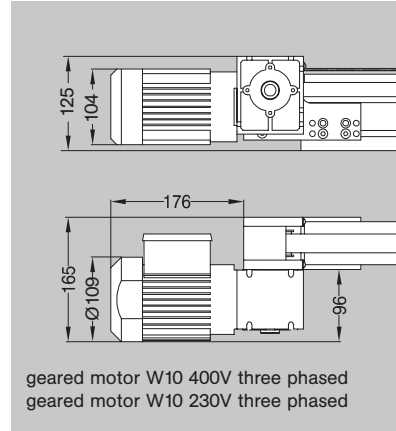
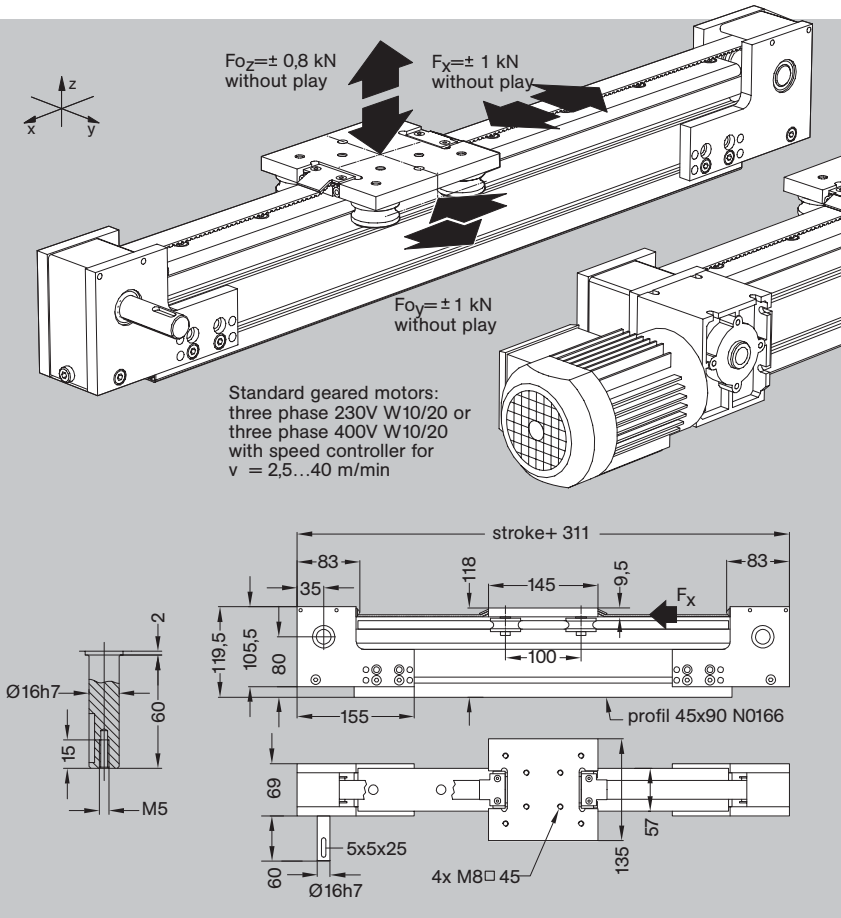

Linear drive and guidance module NAPCC: combination of the linear guide NAP57 and a toothed belt AT 5x25 incorporated in a 45x90 NORCAN profile.

Smooth and silent in use, without play.

Speed: up to 2 m/s, for higher speeds contact our technical department.

Drive ratio: 180 mm/rev.

Loads: the drawing above shows, centred on the carriage, the static loads F_{oy} and F_{oz} which may **not** be combined. For all other types of loads see p.53. For F_x the maximum load on the belt is about 1kN bearing in mind that any force which is not exactly lined up with the centre of the belt will create a moment putting an extra load onto the rollers of the linear guide (see example p. 61).

Standard geared motors: three phase 230V WA10 or 400V W10 with or without speed controller for speeds from 3 to 40 m/min. For higher loads use W20 geared motors.

Important: The tension of the WA10... motors is preselected, so when ordering indicate whether 400V triph. (Y) or 230V triph. (Δ).

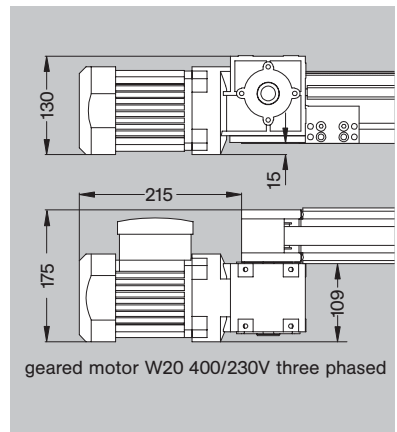
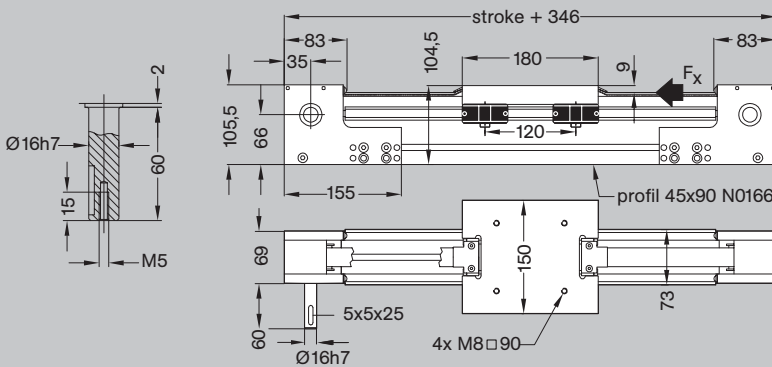
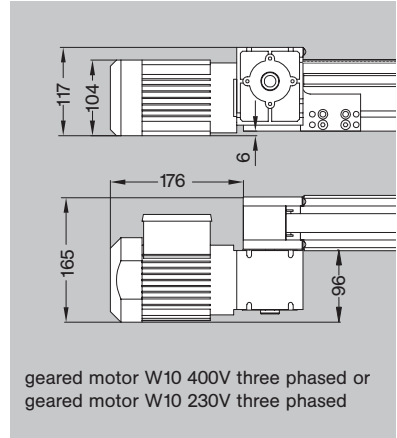
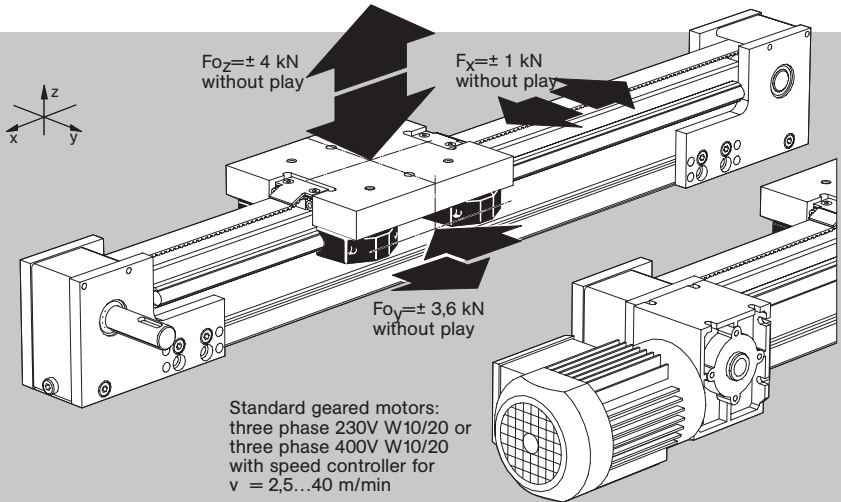

Linear drive and guidance module K12CC: combination of the linear guide K12 and a toothed belt AT 5x25 incorporated in a 45x90 NORCAN profile.

Rigid without play for higher loads.

Speed: up to 10 m/s, higher speeds contact our technical department.

Drive ratio: 180 mm/rev.

Loads: the drawing above shows, centred on the carriage, the static loads F_{oy} and F_{oz} which may **not** be combined. For all other types of loads see p.56. For F_x the maximum load on the belt is about 1kN bearing in mind that any force which is not exactly lined up with the centre of the belt will create a moment putting an extra load onto the rollers of the linear guide (see example besides).

Standard geared motors: three phase 230V WA10 or 400V W10 with or without speed controller for speeds from 3 to 40 m/min. For higher loads use W20 geared motors.

Important: The tension of the WA10... motors is preselected, so when ordering indicate whether 400V triph. (Y) or 230V triph. (Δ).

Example: The linear module NAPCC above accelerates with $a = 4 \text{ ms}^{-2}$, a mass of $m = 50 \text{ kg}$ whose centre is situated 300 mm above the middle of the carriage.

The weight of m will create on each roller an axial load of:

$$F_{ax}(m) = \frac{1}{4} mg = \frac{1}{4} \cdot 50 \text{ kg} g = 125 \text{ N}$$

The acceleration of m will create the following moment:

$$M_y(a) = ma(300 + 9) \text{ mm} = 50 \text{ kg} \cdot 4 \text{ ms}^{-2} \cdot 309 \text{ mm} = 62 \text{ Nm}$$

putting on each roller an additional axial load:

$$F_{ax}(a) = \frac{1}{2} M_y(a) / 120 \text{ mm} = 258 \text{ N}$$

Which will be added or subtracted from the axial load $F_{ax}(m)$.

So the maximum axial force per roller will be:

$$F_{ax \text{ max}} = 125 \text{ N} + 258 \text{ N} = 383 \text{ N}$$

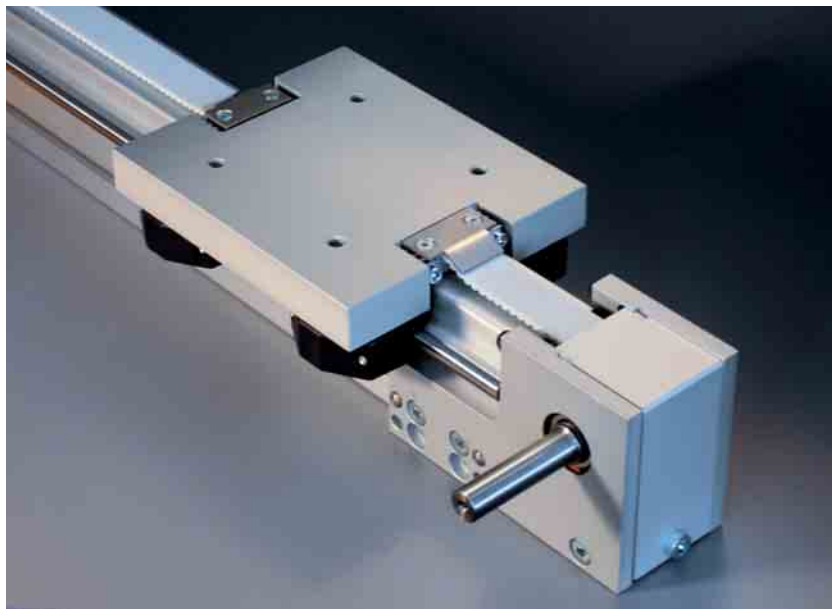

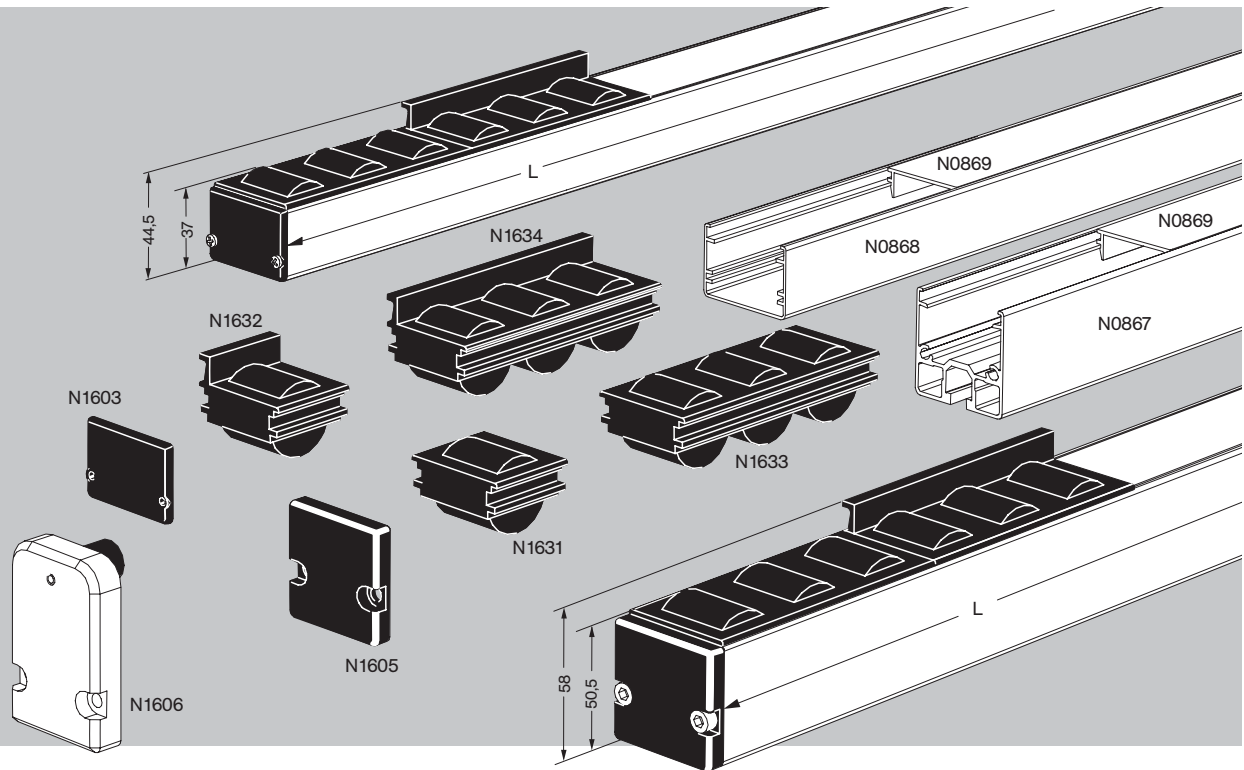

L[mm]	N1633 N1634	N1631 N1632	L[mm]	N1633 N1634	N1631 N1632	L[mm]	N1633 N1634	N1631 N1632
327	3	0	872	8	0	1 417	13	0
363	3	1	908	8	1	1 453	13	1
399	3	2	944	8	2	1 489	13	2
436	4	0	981	9	0	1 526	14	0
472	4	1	1 017	9	1	1 562	14	1
508	4	2	1 053	9	2	1 598	14	2
545	5	0	1 090	10	0	1 635	15	0
581	5	1	1 126	10	1	1 671	15	1
617	5	2	1 162	10	2	1 707	15	2
654	6	0	1 199	11	0	1 744	16	0
690	6	1	1 235	11	1	1 780	16	1
726	6	2	1 271	11	2	1 816	16	2
763	7	0	1 308	12	0	1 853	17	0
799	7	1	1 344	12	1	1 889	17	1
835	7	2	1 380	12	2	1 925	17	2

Conveyor rails : with very low friction coefficient to transport panels, small containers, small pallets etc. maximum load 150N/roller. Material: anodized aluminium, rollers of PA 6.6. the table below assists in ordering the elements to build conveyor rails to the length L ($L_{max} = 6\text{ m}$).

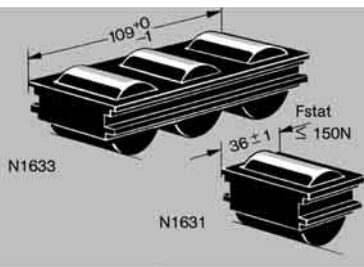

Roller unit with 3 rollers - N1633
Roller unit with 1 roller - N1631 :

To build conveyors with the U section profiles N0867 and N0868 (p. 63).

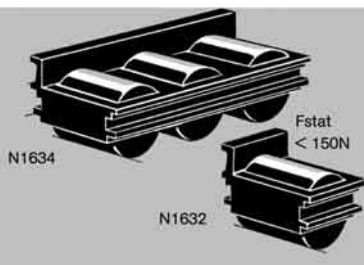

Roller unit with 3 rollers and side plate - N1634
Roller unit with 1 roller and side plate - N1632 :

To build conveyors with the U section profiles N0867 and N0868 (p. 63).

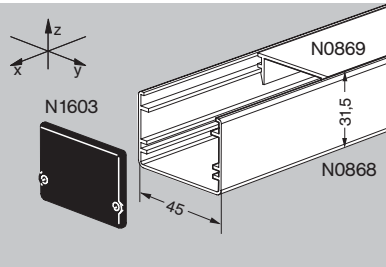

U section profile 31,5 x 45 - N 0868 : light profile for roller units. To be mounted with screws or double sided adhesive tape onto NORCAN structures. Material: anodised aluminium. $I_y = 2 \cdot 10^4 \text{ mm}^4$

Snap in cover for U profile - N 0869 : Material: anodised aluminium.

End cap 31,5x45 for U profile N 0868 - N 1603 : with possibility for cable passage $\varnothing 16$ and 2 parker screws. Material: PA 6.6 30% GF.

These items may equally be used to provide a neat solution for routing cables, air lines etc (see p.68).

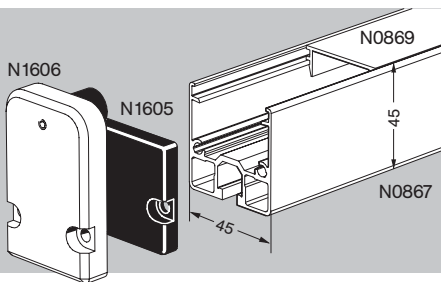

U section profile 45x45 - N 0867 : for roller units. Material: anodised aluminium. $I_y = 5 \cdot 10^4 \text{ mm}^4$

Snap in cover for U profile - N 0869 : Material: anodised aluminium.

End cap 45x45 for U profile N 0867 - N 1605 : with possibility for cable passage $\varnothing 16$ and 2 M5x20 screws. Material: PA 6.6 30% GF.

End stop for profile N 0867 - N 1606 : with 2 M5x30 screws and a rubber buffer 15x15mm. F(corresponding to the maximum shear stress on the M5x20 screws) $\approx 1,5 \text{ kN}$ corresponding to an impact energy of $\approx 7 \text{ J}$. Material: anodised aluminium.

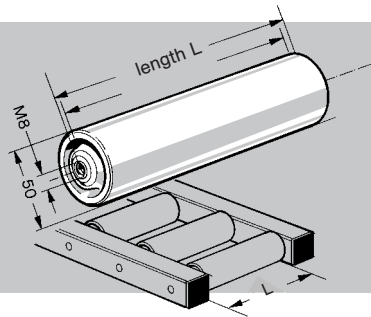

Conveyor roller. Low friction, for gravity conveyors.

$\varnothing 50$ steel rollers on M8-tapped 12 mm shaft.

On request : synthetic rollers and stainless steel bearings.

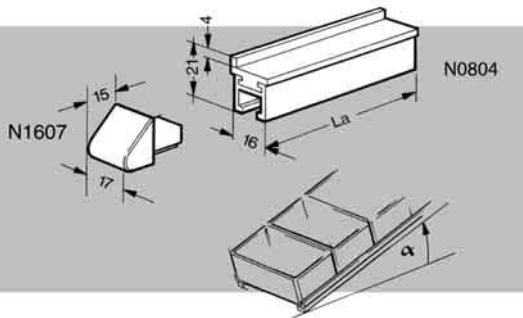
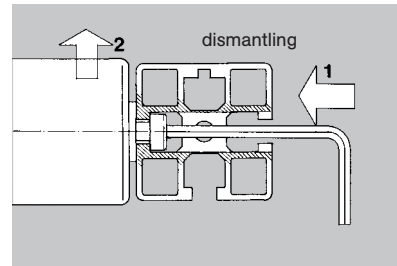

Slide rail - N 0804 : for gravity feeding small pieces, small containers, circuit boards etc. to workstations. The inclination angle α must be determined by tests. Material: anodised aluminium, contact face in PE HD.

Plug for slide rail - N 1607 : material: PA 6.6 uncoloured.

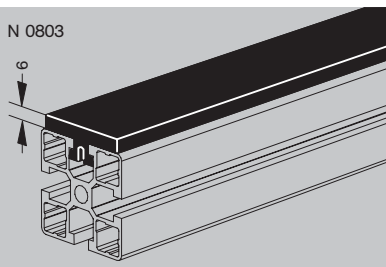

PE profile 6 x 45 - N 0803 : for slide profiles and lateral guides.

Material: black PE. Maximum length 2000 mm.

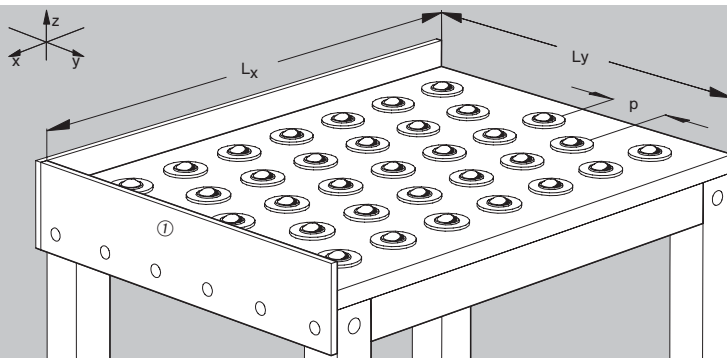

Ball table : for the transport of panels, flat bottom containers, cardboard packages, and other it flat surfaced objects.

The panel is made in 20mm PE with ball at 50 or 100mm spacings, staggered.

With or without side boards ①.

For all design please contact us.

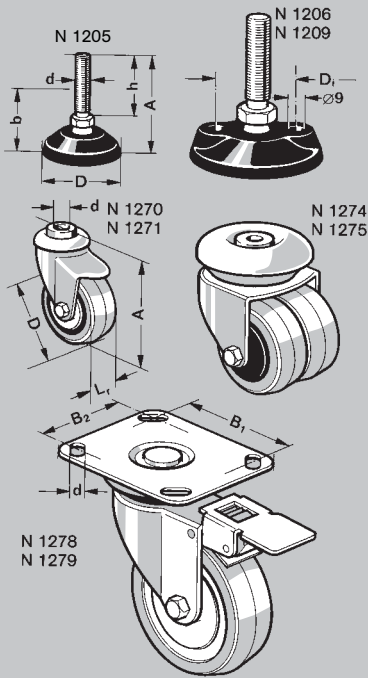

Adjustables Feet: black polyamide feet with antivibration pad and swivelling bolt. Refer to table underneath for types and dimensions.

Feet	Standard height b	Dimensions [mm]				h	Maximum load [N]
		A	d	D	D ₁		
N 1205	40 ± 5	64	M 8	50	-	40	3 000
N 1206	45 ± $\frac{30}{10}$	94	M 10	80	54	67	3 000
N 1209	55 ± $\frac{50}{10}$	131	M 16 ¹⁾	80	54	100	10 00
N 1212	120 ± $\frac{140}{30}$	280	M 20 ¹⁾	123	-	211	20 000
N 1211 stainless	55 ± $\frac{80}{10}$	160	M 16 ¹⁾	90	-	115	-

¹⁾ To be fitted on a mounting base

Castors Wheels: chrome plated mounting supports, grey rubber tyre. (N 1280/1/2: polypropylene wheel, for heavy loads)

Refer to table underneath for types and dimensions.

Castor	A	B ₁	B ₂	d	D	L _r	Lock	Maximum load [N]
N 1270	98	-	-	10,5	75	25	no	600
N 1271	98	-	-	10,5	75	25	yes	600
N 1274	98	-	-	10,2	75	50	no	800
N 1275	98	-	-	10,2	75	50	yes	800
N 1278	132	75...61	45...51	8,5	100	32	no	900
N 1279	132	75...61	45...51	8,5	100	32	yes	900
N 1280	128	77...80	60	9	100	36	no	1 500
N 1281	128	77...80	60	9	100	36	yes	1 500
N 1282	non swivelling version of N 1280						no	1 500

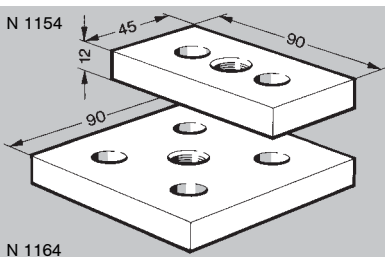
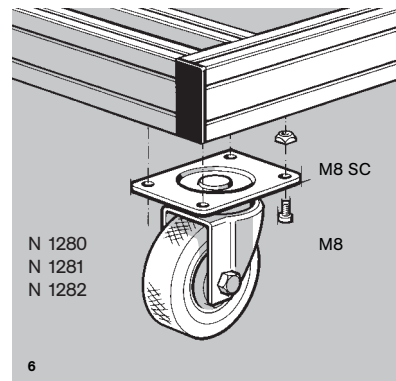
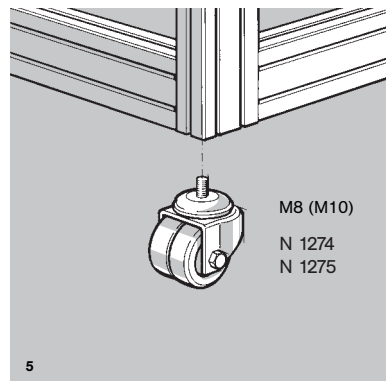
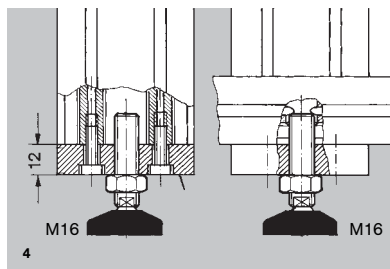
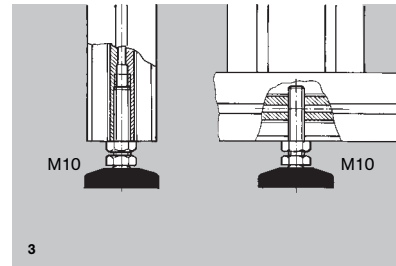
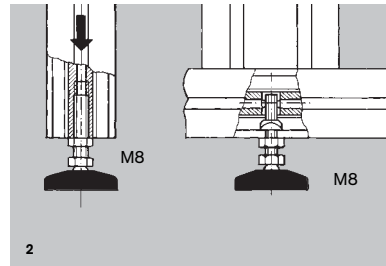
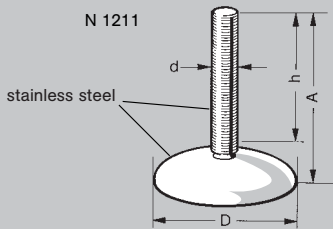

Mounting Bases: To mount feet and castor wheels with M8 to M20 bolt. (other threads on request), with 2 (4) M8x20 bolts. Material: plain anodised aluminium.

Dimensions	Thread M8	M10	M16	M20
45 x 90	N 1151	N 1152	N 1154	N 1155
90 x 90		N 1162	N 1164	N 1165

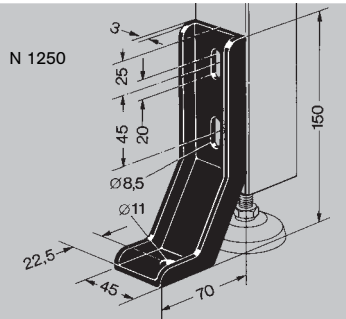

Anchor Angle - N 1250 : with 2 M8 x 16 screws, 2 washers and 2 M8 SC nuts: used to anchor the uprights of structures on the floor.
Material : Pressed steel, black epoxy finish.

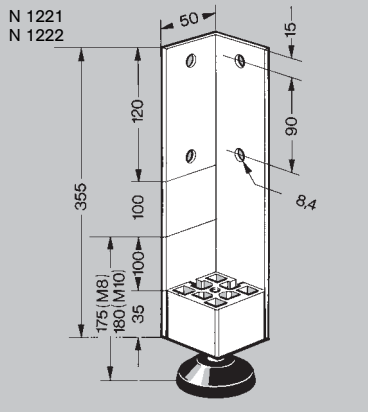

M8 Adjustable Foot ± 100 - N 1221
M10 Adjustable Foot ± 100 - N 1222

Material : Anodised aluminium, foot black polyamide, bolt galvanised steel.

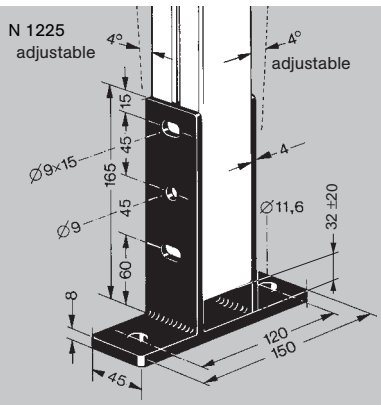

Anchor Foot 45 x 45 - N 1225 : with 6 screws M8 x 20, washers and M8 SC nuts. For adjustable feet made of NORCAN 45 x 45, 45 x 90 and 45 x 180 profiles. For the last two profiles, two anchor feet may be used.

Anchor Foot 45 x 90 - N 1226 : with 6 screws M8 x 20, washers and M8 SC nuts. For adjustable feet made of NORCAN 45 x 90, 90 x 90 and 90 x 180 profiles. For the last two profiles, two anchor feet may be used.

Advantage : Easily adjustable for height and perpendicularity.
Material : black epoxy coated steel.

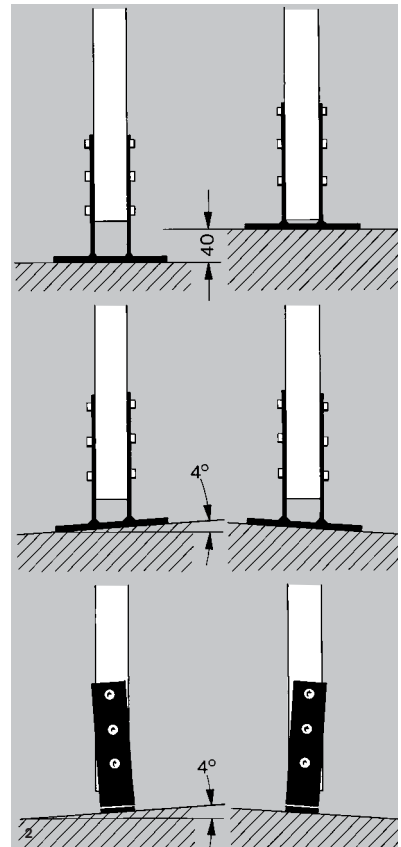
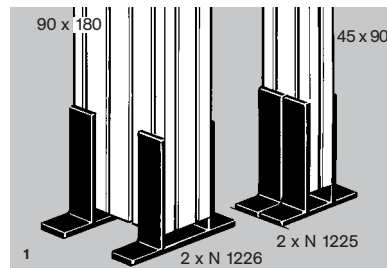
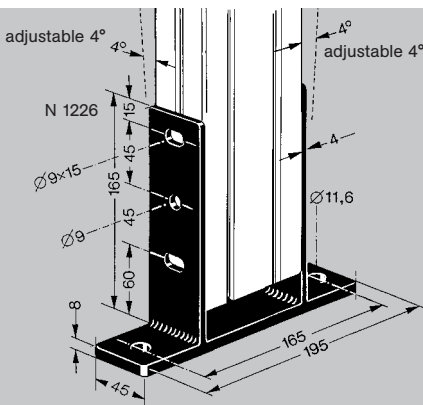

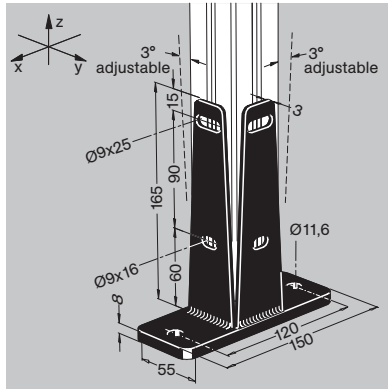

Anchor foot 45x45 half closed - N 1227 : with 2 M8x20 screws, 2 washers and 2 M8SC nuts. Used to anchor uprights made of half closed profiles to the floor.

Advantage : easily adjustable for height and perpendicularity.

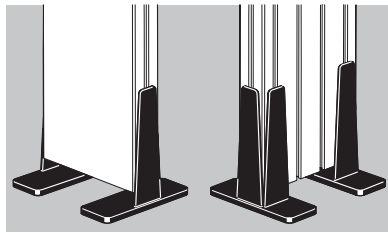
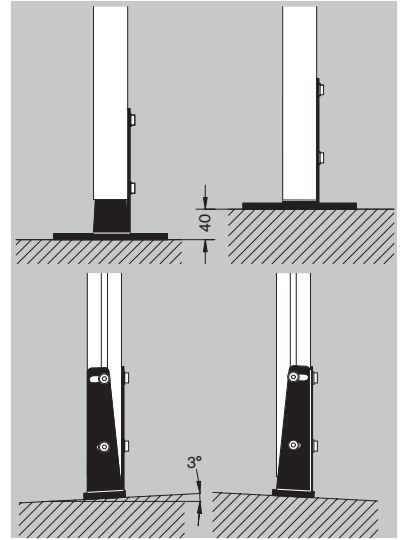
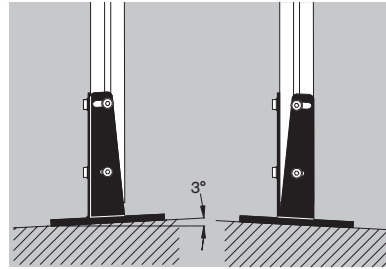

N 0670

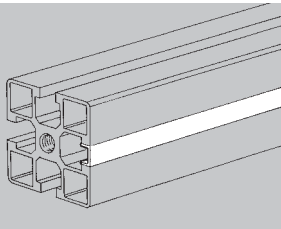

Masking strip anodised - N 0670 : to seal the profile slots. Ideal for fixing and covering cables in the profile slots.

Material : anodised aluminium.

Length : 3 m

For cutting this profile we recommend using the scissors N 5713 on page 69.

N 0712

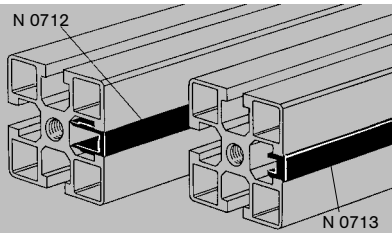

Masking strip - N 0712 in black PVC, available 3 m length,
N 0721 in blue PVC, available 3 m length,
N 0724 in grey PP, available 3 m length.

Masking strip - N 0713 in black rubber to seal the profile slots. Push in. Available in 20 m length

Material : black nitrile rubber.

new: available in black and aluminium coloured ABS!

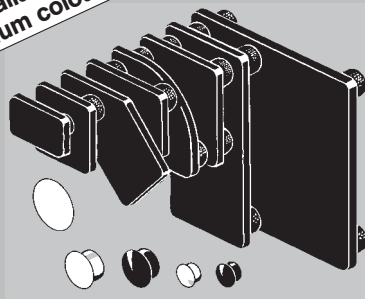

End Plates : end covers for profiles, to be pushed in. Material : black ABS aluminium grey.

black	grey	dimensions	black	grey	dimensions
N 1701	N 2701	18 x 31,5 x 2,5	N 1705	N 2705	45 x 45 x 2,5
N 1702	N 2702	18 x 45 x 2,5	N 1706	N 2706	45 x 90 x 2,5
N 1703	N 2703	31,5 / 31,5 x 2,5	N 1707	N 2707	90 x 90 x 3,5
N 1795	N 2795	31,5 x 45° x 2,5	N 1695	N 2695	45 x 45 x 2,5 triangle
N 1704	N 2704	31,5 x 45 x 2,5	N 1694	N 2694	45 x 45 x 2,5 1/4 round
N 1764	N 2764	31,5 x 90 x 2,5			

Plugs : for holes and countersinks. Material : polyethylene.

N 1715 - Ø 7,4 clear

N 1715 - Ø 7,4 black

N 1717 - Ø 13,5 clear

N 1717 - Ø 13,5 black

N 1719 - **sticker, self adhesive** : for holes other than Ø 7,4 and Ø 13,5.

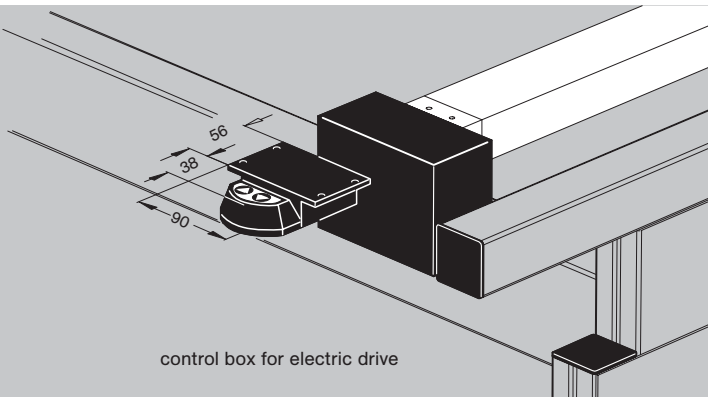
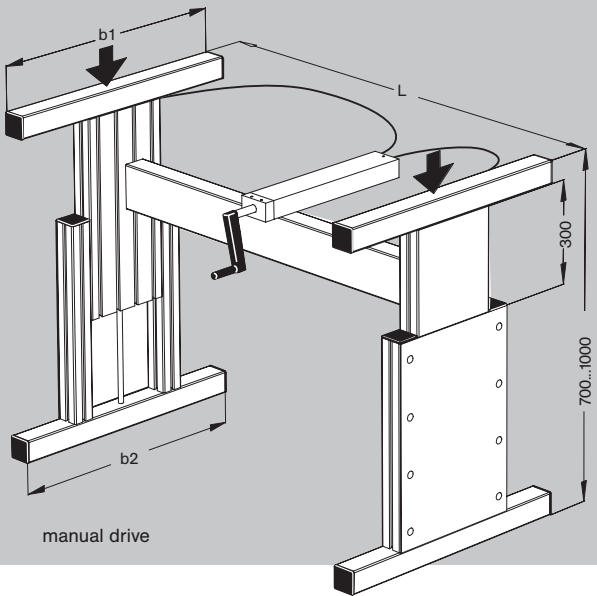

Telescopic legs for ergonomic workstations: Allows optimal height setting of work surfaces.

Technical details:

L = 800; 1000; 1300; 1600 mm or without spacer.

Height : h = 700 à 1000 mm, (stroke 300 mm)

Maximum load per foot: 1500 N

Hydraulic pump in 10 executions to drive 1 to 10 cylinders.

Manual drive: hydraulic pump with crank; 5 mm/revolution.
Pumps for 1 to 10 cylinders.

Electric drive:

230 V AC, 160 to 230 W, CE certified.

Hydraulic pump with electric drive for 1 to 10 cylinders

Important : Our telescopic legs are designed for occasional height regulation but not for continuous service. After 1 minute of service under full load allow to cool down for 20 minutes.

Cylinder: simple acting hydraulic cylinder made of brass/ stainless steel

Stroke 300 mm, speed 400 mm/s maximum. Minimal load to assure the return of the plunger: 60 N/plunger.

Other applications for telescopic legs :

- ergonomic workstations (P. 82)
- mobile workstations
- mobile supports for plates, sheet metal etc
- angle adjustment



Above: ergonomic workstation on standard NORCAN telescopic legs.

Besides: chariot for the transport of wind tunnel models on 2 height adjustable pairs of rollers.



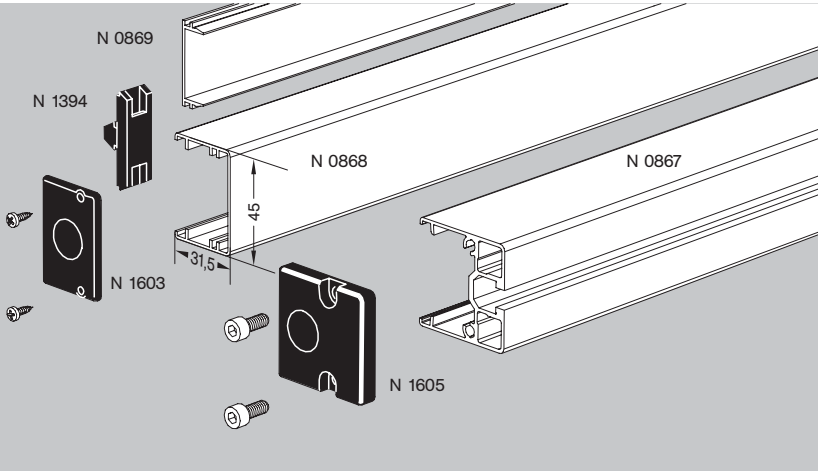

U section profile 31,5 x 45 - N 0868 :

To provide a neat solution for routing cables, air lines, etc. It can be mounted on its supports N 1394 or on snap in cover for U section profile N 0869. Material : anodised aluminium. Maximum length 6000 mm.

U section profile 45 x 45 - N 0867 :

like N0868, the higher moment of inertia and the profile slot allow it to be used as a structural profile.

Support 1/4 turn for U section profile - N 1394 :

For securing a number of cables or air lines. The U section profile N 0868 clips onto this part. Material : PA, black, temperature - 25° C to 140° C.

Snap in cover for U section profile - N 0869 :

To provide a sealed unit where it is not possible to use a NORCAN profile as a support.

End cap 31,5x45 for U profile N 0868 - N 1603 :

with possibility for cable passage Ø16 and 2 parker screws. Material: PA 6.6 30% GF.

End cap 45 x45 for U profile N 0867 - N 1605 :

with possibility for cable passage Ø16 and 2 M5x8 screws. Material: PA 6.6 30% GF.

Cable grommet Ø16/13 - N 3665 :

for end caps N1603 (will not match on N1605!).

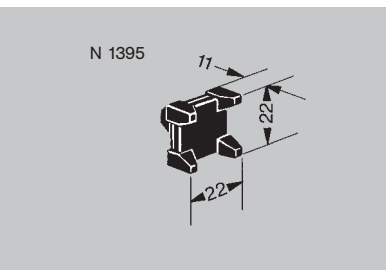
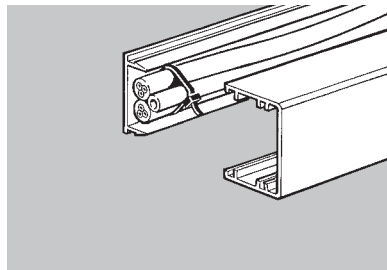
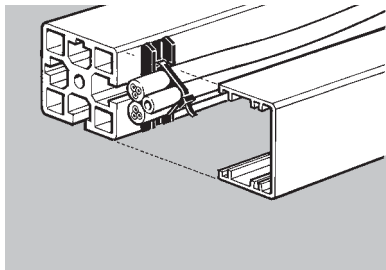

Cable fixing block 1/4 turn N 1395 :

for securing a number of cables or air lines.

Material : Polyamide, black. Temperature : - 25...80° C

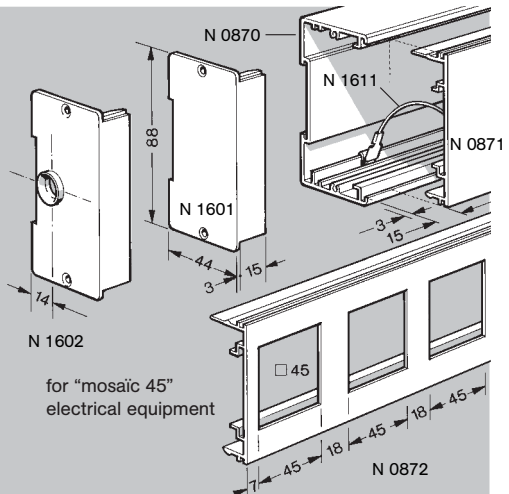
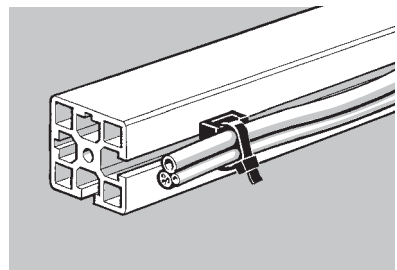

Conduit profile - N 0870 : for electrical installations. Material : plain anodised aluminium. Maximum length 4000 mm.

Conduit profile end cap - N 1601

Conduit profile end cap with cable passage - N 1602

Snap in cover - N 0871 : For conduit profile N 0870. Material : plain anodised aluminium. Maximum length 4000 mm.

Snap in cover with openings 45 x 45 - N 0872 : For conduit profile N 0870. Allows use of "Mosaic 45" accessories. Material : plain anodised aluminium.

Earth connecting wire - N 1611 : Flexible connecting wire with 2 connections. Use one earth wire for each element N 0870, N 0871, N 0872.

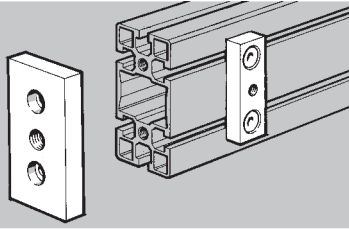

Pneumatic plates : allows to use central core of profile 45x90 mm N 0116 (for any other profile contact us) as a duct. Maximum pressure : 7 bar.

- N 1157** : end plate 12 x 45 x 90 mm with 1/2" tapping
- N 1158** : end plate 12 x 45 x 90 mm with 3/4" tapping
- N 1150** : end plate 12 x 45 x 90 mm w/o tapping
- N 1191** : side connector 12 x 20 x 70 mm with 1/8" tapping
- N 1192** : side connector 12 x 20 x 70 mm with 1/4" tapping
- N 1190** : side connector 12 x 20 x 70 mm w/o tapping
- N 1159** : seal 45 x 90 mm, 0,5 mm thick
- N 1169** : seal 90 x 90 mm, 0,5 mm thick - for any application contact us!

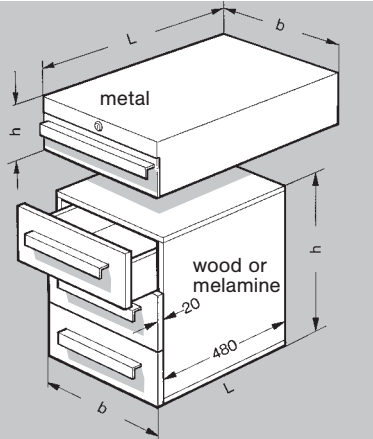

Drawers, enamelled pressed steel : colours : light grey RAL 7035 ; Mounted on silent roller slides. Barrel lock.

Ref.	b	L	h	drawers : number (height from top to bottom)
N 1550	390	665	155	T1 1 drawer (100 mm)
N 1555	430	665	495	B2 2 drawer unit (200 ; 200 mm)
N 1556	430	665	495	B3 4 drawer unit (50 ; 50 ; 100 ; 200 mm)
N 1558	430	665	495	B5 3 drawer unit (100 ; 100 ; 200 mm)
N 1560	310	360	120	TBS1 1 drawer unit (85 mm)

Racks in grey melamine

Ref.	b	L	h	drawers : number (height)
N 1570	400	500	150	1 drawer (150 mm)
N 1573	400	500	450	3 drawer unit (150 ; 150 ; 150 mm)

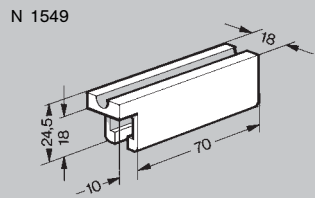

Drawer supports - N 1549

with M8 x 16 screw, washer and M8 SC nut.

Quick fixing for drawer units into NORCAN structures.

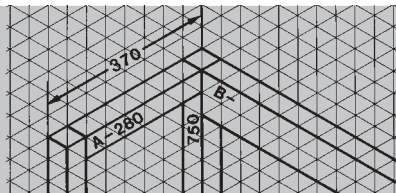
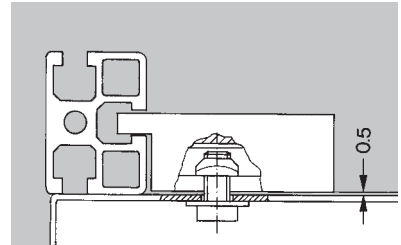

Isometric drawing paper - N 5980 : to facilitate the drawing of your project in an isometric perspective. Hatched in 5x5x5 mm, particularly suited to 1/10 scale, light blue on white background, A3 (297x420 mm) format, supplied in 50 sheet blocks on cardboard support.

Example see page 70.

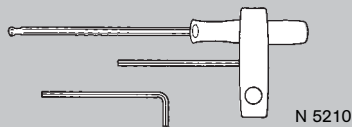

Set of keys - N 5210 : for low head M8 screws (5 mm).

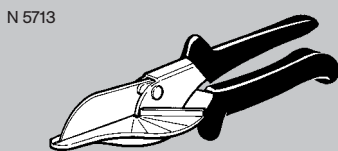

Pair of scissors for strips - N 5713 : for cutting sealing, cover and mounting strips of rubber, PVC and aluminium.

NORCAN isometric paper

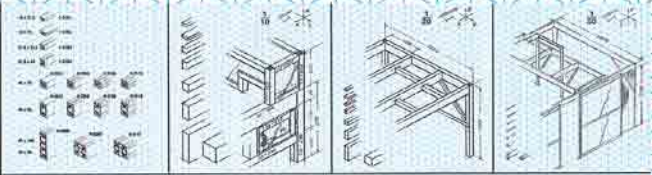

Isometric drawings of NORCAN structures give an excellent impression of the project with easily readable dimensions.

The NORCAN isometric paper with its 5 mm grid is ideal for drawing to $\frac{1}{10}$, $\frac{1}{20}$, $\frac{1}{50}$ size. All lengths **parallel** to the x, y, z axis appear at $\frac{1}{10}$, $\frac{1}{20}$, $\frac{1}{50}$ of their actual length.

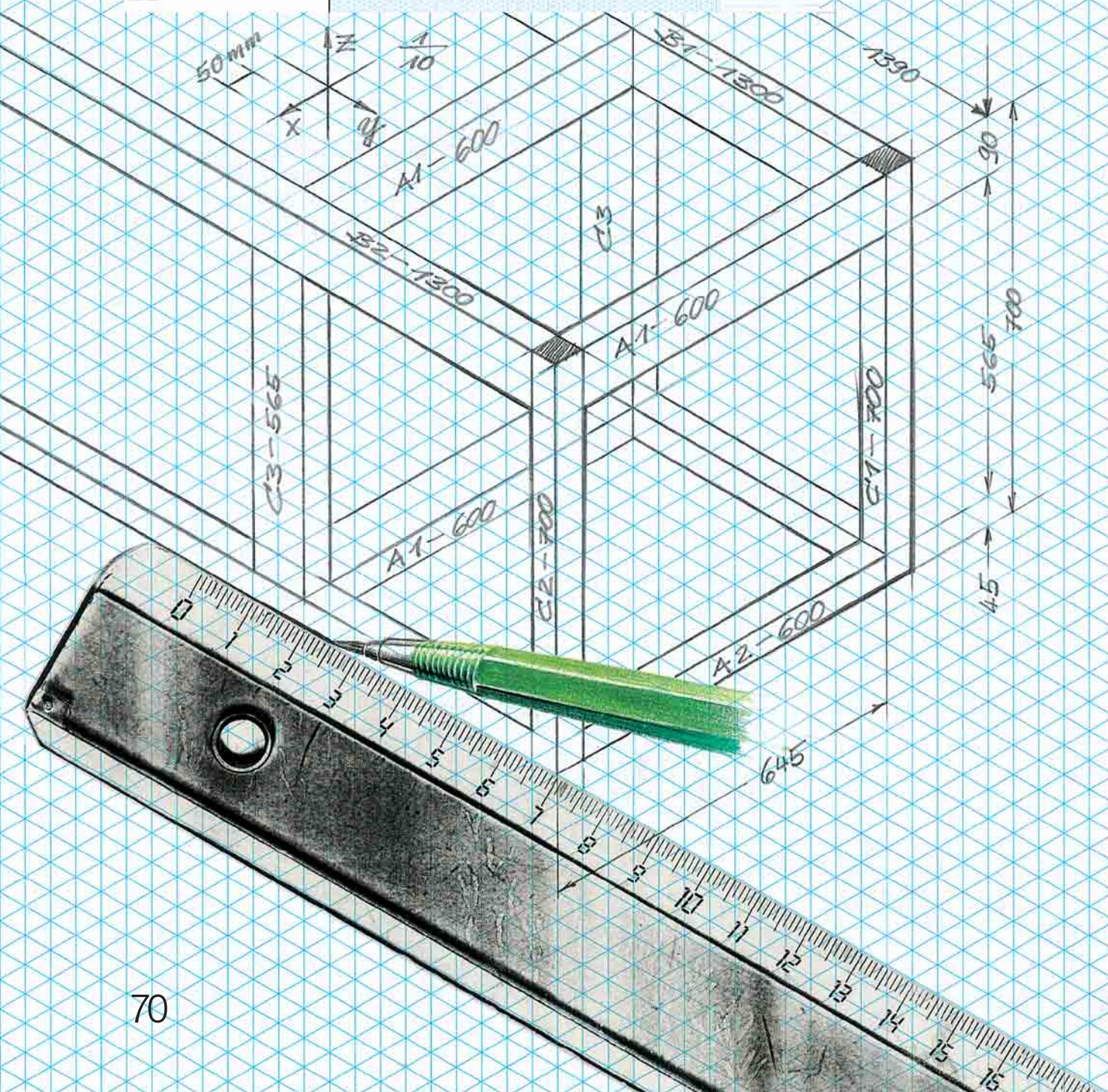

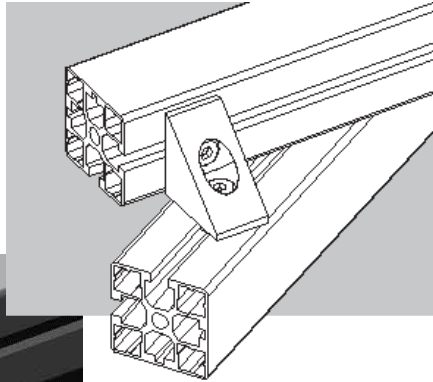

CD rom N_CAD from AutoCAD version 14 and above. Supplied with a 3D library in *.DWG format. It contains:

- NORCAN Profiles
- Panels
- NORCAN Accessories
- NORCAN Conveyor Elements

N_CAD is a software package which facilitates the design of structures incorporating NORCAN profiles and accessories.

It's possible to produce a complete parts list of all the NORCAN elements contained in the design. The software will also calculate weights and prices.

Contains also a 3D library in **IGES** and **STEP** format.

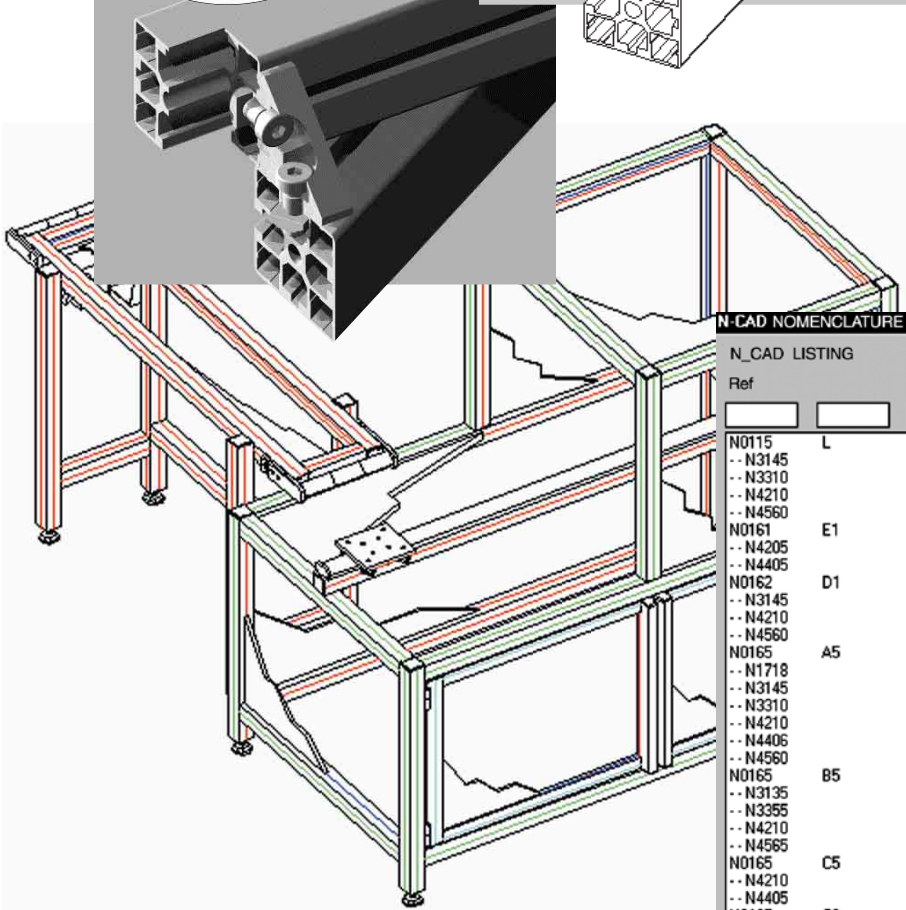

N_CAD NOMENCLATURE

N_CAD LISTING

Ref		Label	Quantity	Length	Width	Ec
N0115	L	Profile 45x45 heavy anodised	1.0	1355.0	0.0	0.0
-- N3145		Low head screw M8x43 zinc coated	2.0	0.0	0.0	0.0
-- N3310		Nut M8 SC zinc coated	2.0	0.0	0.0	0.0
-- N4210		Cut 90° profiles to 55x55	1.0	0.0	0.0	0.0
-- N4560		Drill with counterbore Ø8,4/13,5 flat	2.0	0.0	0.0	0.0
N0161	E1	Profile 18x31,5 anodised	4.0	571.0	0.0	0.0
-- N4205		Cut 90° profiles to 35x35	1.0	0.0	0.0	0.0
-- N4405		Axial end tap M8x25	2.0	0.0	0.0	0.0
N0162	D1	Profile 18x31,5 anodised	2.0	490.0	0.0	0.0
-- N3145		Low head screw M8x43 zinc coated	2.0	0.0	0.0	0.0
-- N4210		Cut 90° profiles to 55x55	1.0	0.0	0.0	0.0
-- N4560		Drill with counterbore Ø8,4/13,5 flat	2.0	0.0	0.0	0.0
N0165	A5	Profile 45x45 anodised	4.0	750.0	0.0	0.0
-- N1718		Plug Ø13,5 dark grey	3.0	0.0	0.0	0.0
-- N3145		Low head screw M8x43 zinc coated	3.0	0.0	0.0	0.0
-- N3310		Nut M8 SC zinc coated	1.0	0.0	0.0	0.0
-- N4210		Cut 90° profiles to 55x55	1.0	0.0	0.0	0.0
-- N4406		Axial end tap M8x40	1.0	0.0	0.0	0.0
-- N4560		Drill with counterbore Ø8,4x13,5 flat	3.0	0.0	0.0	0.0
N0165	B5	Profile 45x45 anodised	2.0	1200.0	0.0	0.0
-- N3135		Square washer zinc coated	2.0	0.0	0.0	0.0
-- N3355		Cut 90° profile to 55x55	2.0	0.0	0.0	0.0
-- N4210		Drill with counterbore Ø8,4x13,5 flat	1.0	0.0	0.0	0.0
-- N4565		Profile 45x45 anodised	2.0	0.0	0.0	0.0
N0165	C5	Cut 90° profile to 55x55	1.0	800.0	0.0	0.0
-- N4210		Axial end tap M8x25	1.0	0.0	0.0	0.0
-- N4405		Profile 45x45 anodised	2.0	0.0	0.0	0.0
N0165	C6	Cut 90° profile to 55x55	2.0	256.0	0.0	0.0
-- N4210		Axial end tap M8x25	1.0	0.0	0.0	0.0
-- N4405		Profile 45x45 anodised	2.0	0.0	0.0	0.0
N0165	B6	Profile 45x45 anodised	2.0	166.0	0.0	0.0
-- N4210			1.0	0.0	0.0	0.0

**Catalogues
Libraries
Software N_CAD**

directly from
www.norcan.fr

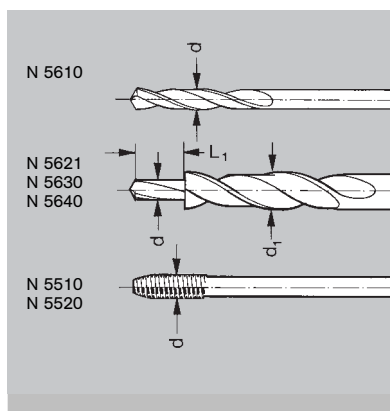
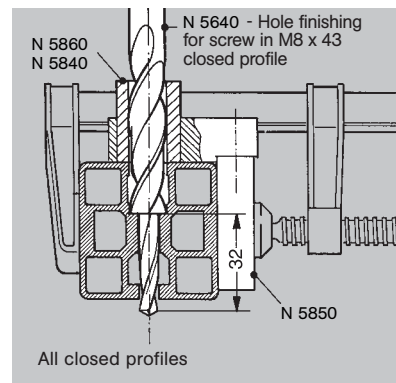
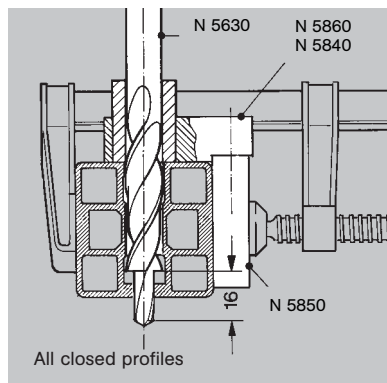
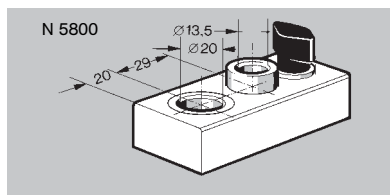
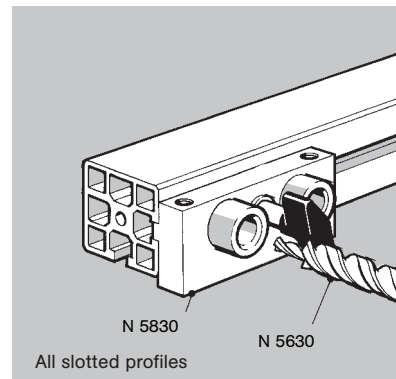
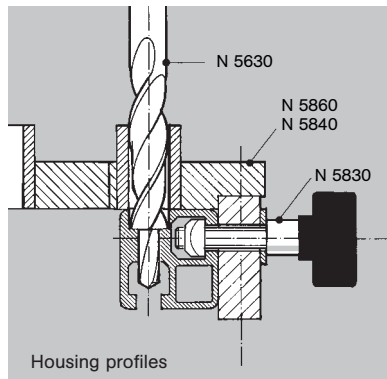
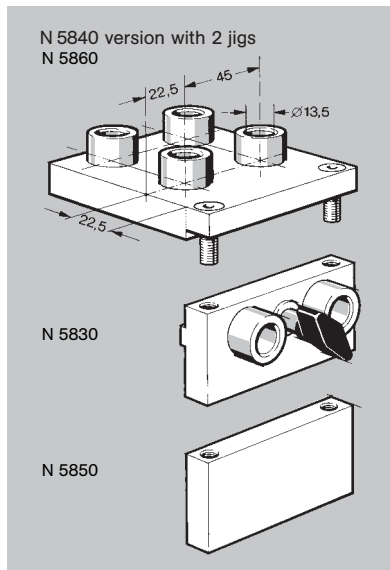
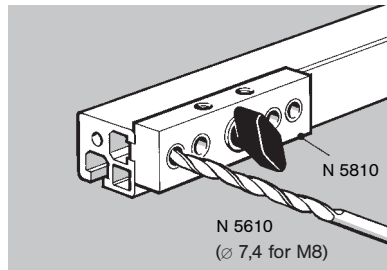
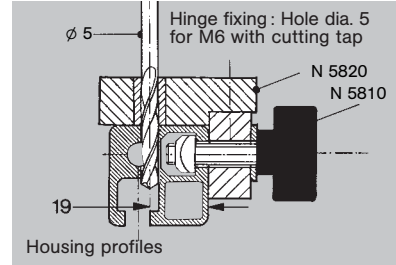
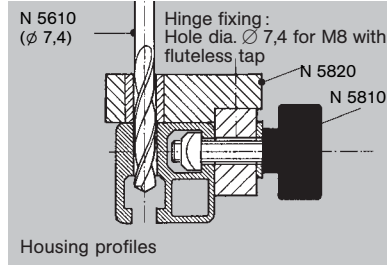
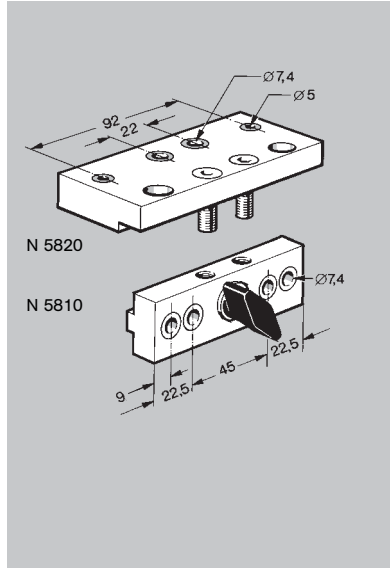

Reference		d	d ₁	L ₁
N 5610	drill (aluminium type) for tapping with fluteless tap M8	7,4	-	-
N 5621	special drill for preparing the tapping with fluteless tap M10 into a 7,4 dia. hole	7,4	9,2	-
N 5630	stepped drill for drilling/countersinking for M8 screws	8,4	13,5	16
N 5640	stepped drill for drilling/countersinking for hole finishing for M8 x 43 screws into closed profiles	8,4	13,5	32
N 5651	stepped drill ø 8,4 x 20	8,4	20	22
N 5510	fluteless tap M8	M8	-	-
N 5520	fluteless tap M10	M10	-	-

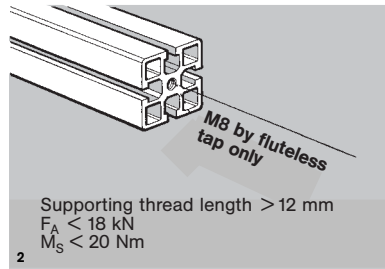

The figures 2-11 opposite illustrate the main means of fixing M8 screws and nuts to NORCAN profiles.

F_A is the maximum shear stress of the screw or of the nut along its axis corresponding to the limit of elasticity of the material of the profile.

M_S is the tightening torque of the bolt or of the nut (a 20 Nm torque is equivalent to a firm tightening with our "T" key).

Fig. 2: M8 axial tapping **with fluteless tap** - identical with all NORCAN profiles.

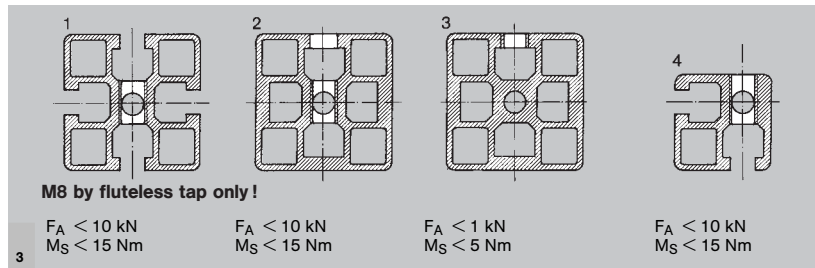

Fig. 3: M8 axial tapping **with fluteless tap**. Tapping in the external side only is for applications with moderate stress.

Radial tapping is not possible in the closed side of N 0275 and N 0276 profiles.

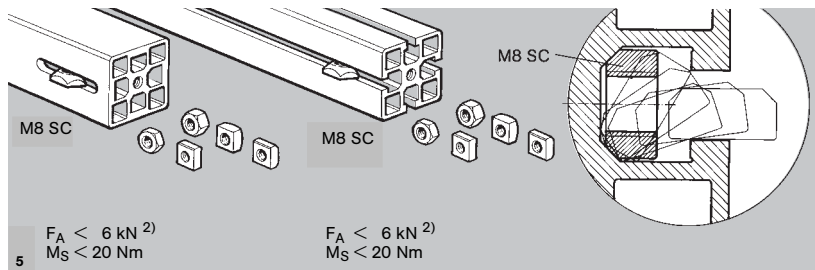

Fig. 5: Standard M8 hex and square nuts (13 mm key) can slide along the slots whilst being prevented from rotating.

The M3 to M8 SC, DSC, LSC, RSC, RLSC nuts can be tilted and inserted into the slot.

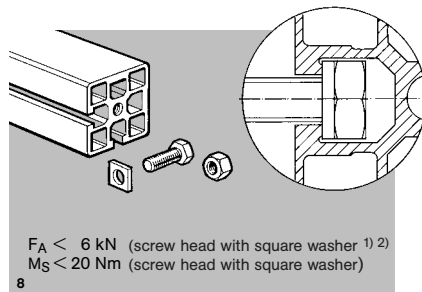

Fig. 8: M8 standard screws (head dia. 13 mm) can slide along the slot. Hex or square-head screws are restrained from rotating.

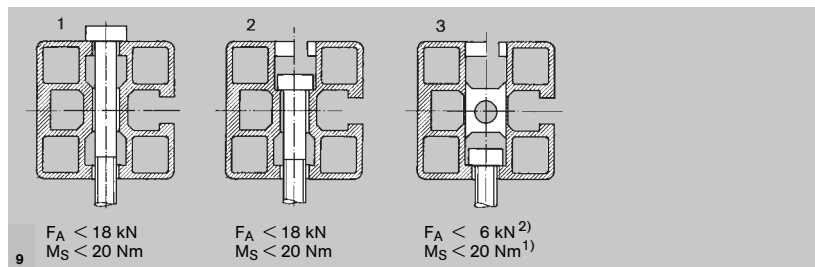

Fig. 9: Screws and counterbore holes at the correct depth.

Attention! refer to figs 9 & 10 on page 56, for 45x90 profiles.

The closed sides of the light profiles N 0275 and N 0276 are not designed as a load bearing face.

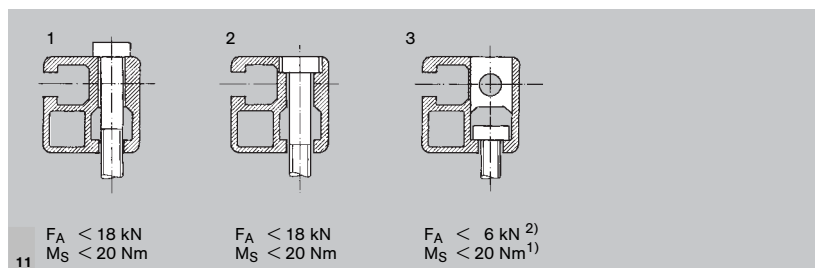
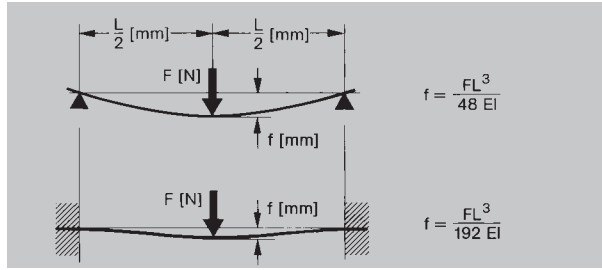

Fig. 11: Holes and countersinks for screws at the correct depth.

1) - Profiles with slots : if using inside the slots fasteners other than a square head without a square washer, M_S will be reduce by 25% and the security factor for F_A has to be increased.

2) - The value of F_A is taken at a distance of 20 mm from the end of the profile. Below 20 mm the value of F_A is reduced by 50%.



Profiles supported at both ends: in practice these normally fall more or less half way between the deflection of a beam resting on two simple supports, and that of a beam "embedded" at the both ends.

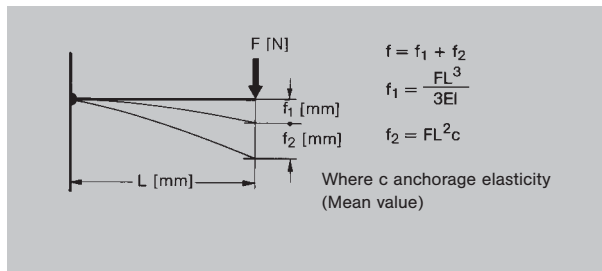

Cantilever Profiles: Under a point-load F, the tip of the cantilever beam will show a deflection f which is made up of the deflection f_1 of the profile beam itself, plus the elastic deformation of the beam anchorage f_2 .

To facilitate the choice between different mounting methods, the most common cases are illustrated below.

For the maximum permissible moment $(F \cdot L)_{max}$ two values are quoted below - The first has been calculated on the basis of the data given in section "Using M8 screws and bolts" with a coefficient of friction of 0.1. The second one (between brackets) is the result of a series of practical tests (see P 75).

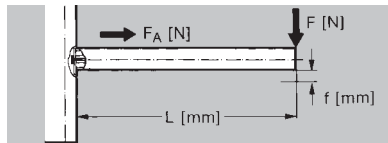

Method A31: NORCAN 45x45 mm fixed with 1 central screw M8x20.

Heavy profiles

$F_{A \max} = 6000 \text{ N}$
 $F_{\max} \text{ (for } L=0) = 1800 \text{ N}$
 $(F \cdot L)_{\max} = 135 \text{ Nm (150 Nm)}$
 $f \approx 35 \cdot 10^{-12} FL^3 + 20 \cdot 10^{-9} FL^2$
 Ex. $F = 100 \text{ N}; L = 1000 \text{ mm} \rightarrow f \approx 5,5 \text{ mm}$

Other profiles ¹⁾

$F_{A \max} = 6000 \text{ N}$
 $F_{\max} \text{ (for } L=0) = 1800 \text{ N}$
 $(F \cdot L)_{\max} = 135 \text{ Nm (150 Nm)}$
 $f \approx 40 \cdot 10^{-12} FL^3 + 35 \cdot 10^{-9} FL^2$
 Ex. $F = 100 \text{ N}; L = 1000 \text{ mm} \rightarrow f \approx 7,5 \text{ mm}$

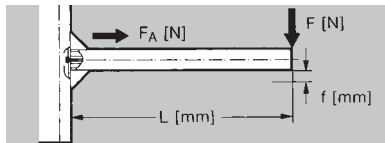

Method B31: NORCAN 45x45 mm fixed with 1 central screw M8x20. plus 2 corner triangles

Heavy profiles

$F_{A \max} = 6000 \text{ N}$
 $F_{\max} \text{ (for } L=0) = 5400 \text{ N}$
 $(F \cdot L)_{\max} = 135 \text{ Nm (250 Nm)}$
 $f \approx 35 \cdot 10^{-12} FL^3 + 3 \cdot 10^{-9} FL^2$
 Ex. $F = 100 \text{ N}; L = 1000 \text{ mm} \rightarrow f \approx 4 \text{ mm}$

Other profiles ²⁾

$F_{A \max} = 6000 \text{ N}$
 $F_{\max} \text{ (for } L=0) = 5400 \text{ N}$
 $(F \cdot L)_{\max} = 135 \text{ Nm (250 Nm)}$
 $f \approx 40 \cdot 10^{-12} FL^3 + 3 \cdot 10^{-9} FL^2$
 Ex. $F = 100 \text{ N}; L = 1000 \text{ mm} \rightarrow f \approx 4,5 \text{ mm}$

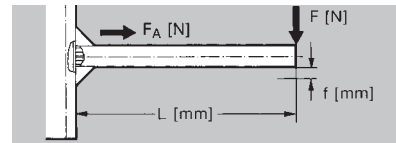

Method C01: NORCAN 45x45 mm fixed with 2 corner triangles without central screw

Heavy profiles

$F_{A \max} = 3600 \text{ N}$
 $F_{\max} \text{ (for } L=0) = 3600 \text{ N}$
 $(F \cdot L)_{\max} = 81 \text{ Nm (230 Nm)}$
 $f \approx 35 \cdot 10^{-12} FL^3 + 3 \cdot 10^{-9} FL^2$
 Ex. $F = 100 \text{ N}; L = 1000 \text{ mm} \rightarrow f \approx 4 \text{ mm}$

Other profiles ²⁾

$F_{A \max} = 3600 \text{ N}$
 $F_{\max} \text{ (for } L=0) = 3600 \text{ N}$
 $(F \cdot L)_{\max} = 81 \text{ Nm (230 Nm)}$
 $f \approx 40 \cdot 10^{-12} FL^3 + 3 \cdot 10^{-9} FL^2$
 Ex. $F = 100 \text{ N}; L = 1000 \text{ mm} \rightarrow f \approx 4,5 \text{ mm}$

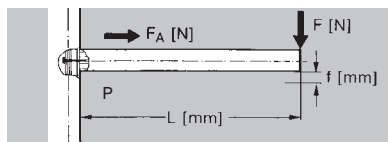

Method A21: NORCAN 45x45 mm fixed with 1 central screw M8x43

Heavy profiles

$F_{A \max} = 18000 \text{ N}$
 $F_{\max} \text{ (for } L=0) = 1800 \text{ N}$
 $(F \cdot L)_{\max} = 292 \text{ Nm (300 Nm)}^{3)}$
 $f \approx 35 \cdot 10^{-12} FL^3 + 10 \cdot 10^{-9} FL^2$
 Ex. $F = 100 \text{ N}; L = 1000 \text{ mm} \rightarrow f \approx 4,5 \text{ mm}$

Other profiles ¹⁾

$F_{A \max} = 18000 \text{ N}$
 $F_{\max} \text{ (for } L=0) = 1800 \text{ N}$
 $(F \cdot L)_{\max} = 292 \text{ Nm (300 Nm)}^{3)}$
 $f \approx 40 \cdot 10^{-12} FL^3 + 15 \cdot 10^{-9} FL^2$
 Ex. $F = 100 \text{ N}; L = 1000 \text{ mm} \rightarrow f \approx 5,5 \text{ mm}$

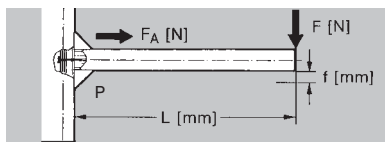

Method B21: NORCAN 45x45 mm fixed with a central screw M8x43 plus two corner triangles

Heavy profiles

$F_{A \max} = 18000 \text{ N}$
 $F_{\max} \text{ (for } L=0) = 5400 \text{ N}$
 $(F \cdot L)_{\max} = 292 \text{ Nm (300 Nm)}^{3)}$
 $f \approx 35 \cdot 10^{-12} FL^3 + 3 \cdot 10^{-9} FL^2$
 Ex. $F = 100 \text{ N}; L = 1000 \text{ mm} \rightarrow f \approx 4,0 \text{ mm}$

Other profiles ²⁾

$F_{A \max} = 18000 \text{ N}$
 $F_{\max} \text{ (for } L=0) = 5400 \text{ N}$
 $(F \cdot L)_{\max} = 292 \text{ Nm (300 Nm)}^{3)}$
 $f \approx 40 \cdot 10^{-12} FL^3 + 3 \cdot 10^{-9} FL^2$
 Ex. $F = 100 \text{ N}; L = 1000 \text{ mm} \rightarrow f \approx 4,5 \text{ mm}$

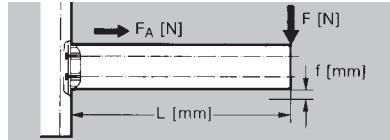

Method A32 : NORCAN 45x90 mm fixed with 2 central screws

Heavy profiles

$F_{A \max} = 12000 \text{ N}$
 $F_{\max} \text{ (for } L=0) = 3600 \text{ N}$
 $(F \cdot L)_{\max} = 450 \text{ Nm (600 Nm)}$
 $f \approx 4,5 \cdot 10^{-12} FL^3 + 3,5 \cdot 10^{-9} FL^2$
 Ex. $F = 100 \text{ N} ; L = 1000 \text{ mm} \rightarrow f \approx 0,8 \text{ mm}$

Other profiles ¹⁾

$F_{A \max} = 12000 \text{ N}$
 $F_{\max} \text{ (for } L=0) = 3600 \text{ N}$
 $(F \cdot L)_{\max} = 450 \text{ Nm (600 Nm)}$
 $f \approx 5,5 \cdot 10^{-12} FL^3 + 6,5 \cdot 10^{-9} FL^2$
 Ex. $F = 100 \text{ N} ; L = 1000 \text{ mm} \rightarrow f \approx 1,2 \text{ mm}$

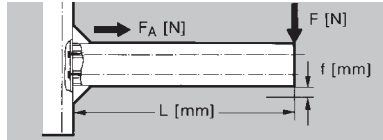

Method B32 : NORCAN 45x90 mm fixed with 2 central screws plus 2 corner triangles

Heavy profiles

$F_{A \max} = 12000 \text{ N}$
 $F_{\max} \text{ (for } L=0) = 7200 \text{ N}$
 $(F \cdot L)_{\max} = 450 \text{ Nm (900 Nm)}$
 $f \approx 4,5 \cdot 10^{-12} FL^3 + 2 \cdot 10^{-9} FL^2$
 Ex. $F = 100 \text{ N} ; L = 1000 \text{ mm} \rightarrow f \approx 0,7 \text{ mm}$

Other profiles ^{1) 2)}

$F_{A \max} = 12000 \text{ N}$
 $F_{\max} \text{ (for } L=0) = 7200 \text{ N}$
 $(F \cdot L)_{\max} = 450 \text{ Nm (900 Nm)}$
 $f \approx 5,5 \cdot 10^{-12} FL^3 + 2 \cdot 10^{-9} FL^2$
 Ex. $F = 100 \text{ N} ; L = 1000 \text{ mm} \rightarrow f \approx 0,8 \text{ mm}$

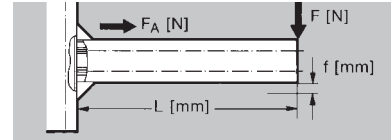

Method C02 : NORCAN 45x90 mm fixed with 2 corner triangles without central screw

Heavy profiles

$F_{A \max} = 3600 \text{ N}$
 $F_{\max} \text{ (for } L=0) = 3600 \text{ N}$
 $(F \cdot L)_{\max} = 162 \text{ Nm (550 Nm)}$
 $f \approx 4,5 \cdot 10^{-12} FL^3 + 2 \cdot 10^{-9} FL^2$
 Ex. $F = 100 \text{ N} ; L = 1000 \text{ mm} \rightarrow f \approx 0,7 \text{ mm}$

Other profiles ^{1) 2)}

$F_{A \max} = 3600 \text{ N}$
 $F_{\max} \text{ (for } L=0) = 3600 \text{ N}^{2)}$
 $(F \cdot L)_{\max} = 162 \text{ Nm (550 Nm)}$
 $f \approx 5,5 \cdot 10^{-12} FL^3 + 2 \cdot 10^{-9} FL^2$
 Ex. $F = 100 \text{ N} ; L = 1000 \text{ mm} \rightarrow f \approx 0,8 \text{ mm}$

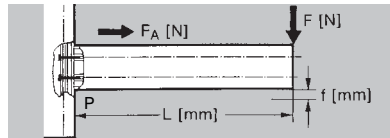

Method A22 : NORCAN 45x90 mm fixed with 2 central screws M8x43

Heavy profiles

$F_{A \max} = 36000 \text{ N}$
 $F_{\max} \text{ (for } L=0) = 3600 \text{ N}$
 $(F \cdot L)_{\max} = 731 \text{ Nm (800 Nm)}^{3)}$
 $f \approx 4,5 \cdot 10^{-12} FL^3 + 2 \cdot 10^{-9} FL^2$
 Ex. $F = 100 \text{ N} ; L = 1000 \text{ mm} \rightarrow f \approx 0,7 \text{ mm}$

Other profiles ¹⁾

$F_{A \max} = 36000 \text{ N}$
 $F_{\max} \text{ (for } L=0) = 3600 \text{ N}$
 $(F \cdot L)_{\max} = 731 \text{ Nm (800 Nm)}$
 $f \approx 5,5 \cdot 10^{-12} FL^3 + 4 \cdot 10^{-9} FL^2$
 Ex. $F = 100 \text{ N} ; L = 1000 \text{ mm} \rightarrow f \approx 1 \text{ mm}$

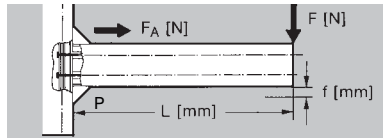

Method B22 : NORCAN 45x90 mm fixed with 2 central screws M8x43 plus 2 corner triangles

Heavy profiles

$F_{A \max} = 36000 \text{ N}$
 $F_{\max} \text{ (for } L=0) = 7200 \text{ N}$
 $(F \cdot L)_{\max} = 731 \text{ Nm (900 Nm)}^{3)}$
 $f \approx 4,5 \cdot 10^{-12} FL^3 + 2 \cdot 10^{-9} FL^2$
 Ex. $F = 100 \text{ N} ; L = 1000 \text{ mm} \rightarrow f \approx 0,7 \text{ mm}$

Other profiles ²⁾

$F_{A \max} = 36000 \text{ N}$
 $F_{\max} \text{ (for } L=0) = 7200 \text{ N}$
 $(F \cdot L)_{\max} = 731 \text{ Nm (900 Nm)}^{3)}$
 $f \approx 5,5 \cdot 10^{-12} FL^3 + 2 \cdot 10^{-9} FL^2$
 Ex. $F = 100 \text{ N} ; L = 1000 \text{ mm} \rightarrow f \approx 0,8 \text{ mm}$

Conditions of test :

Profiles: Material NF6060 T56 (\cong DIN Al Mg Si 0,5 F 25), shear stress 250 Nmm⁻², elastic limit > 200 Nmm⁻², anodised 15 μ m.

Screws and Bolts: All tests carried out with M8x20 or 43 low-head socket screws, quality 8.8 zinc coated, threads and bearing face MoS₂ treated, tightened at 20 Nm with torque wrench which is equivalent to a vigorous manual tightening with our Allen key N 5210 and ensures a preload of about 18 kN. For profiles with slots, screw heads were resting on N 3355 square washers for a better load distribution. Nuts used were M8 SC NORCAN nuts.

For all tests the point of maximum load (F_A) and the compression resistance at point P) is taken at a minimum distance of 20 mm from the end of the vertical profile. Below 20 mm the value of the admissible load (F, F_A), the compression resistance at point P and the resulting torques $F \cdot L$ and stiffness are reduced until 50% towards the end of the profile.

Limit load $F_{A \max}; F_{\max}; (FL)_{\max}$ are the maximum loads before occurrence of the first signs of permanent deformation or sliding.

The limit loads $F_{A \max}; F_{\max}; (FL)_{\max}$ are not cumulative and correspond to profiles of nominal dimensions.

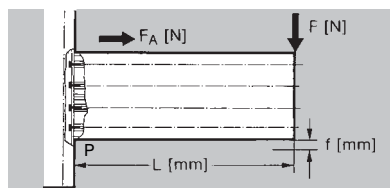

Method A34 : NORCAN 45x180 mm fixed with 4 central screws M8x20

Heavy profiles

$F_{\max} \text{ (for } L=0) = 7200 \text{ N}$
 $(F \cdot L)_{\max} = 1536 \text{ Nm}^{3)}$
 $f \approx 0,6 \cdot 10^{-12} FL^3 + 1 \cdot 10^{-9} FL^2$
 Ex. $F = 100 \text{ N} ; L = 1000 \text{ mm} \rightarrow f \approx 0,2 \text{ mm}$

Other profiles ¹⁾

$F_{\max} \text{ (for } L=0) = 7200 \text{ N}$
 $(F \cdot L)_{\max} = 1536 \text{ Nm}^{3)}$
 $f \approx 0,7 \cdot 10^{-12} FL^3 + 1 \cdot 10^{-9} FL^2$
 Ex. $F = 100 \text{ N} ; L = 1000 \text{ mm} \rightarrow f \approx 0,2 \text{ mm}$

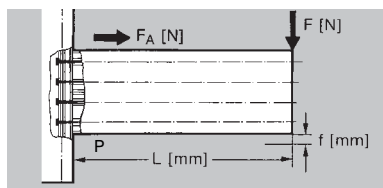

Method A24 : NORCAN 45x180 mm fixed with 4 central screws M8x43

Heavy profiles

$F_{\max} \text{ (for } L=0) = 7200 \text{ N}$
 $(F \cdot L)_{\max} = 1536 \text{ Nm}^{3)}$
 $f \approx 0,6 \cdot 10^{-12} FL^3 + 0,5 \cdot 10^{-9} FL^2$
 Ex. $F = 100 \text{ N} ; L = 1000 \text{ mm} \rightarrow f \approx 0,1 \text{ mm}$

Other profiles ¹⁾

$F_{\max} \text{ (for } L=0) = 7200 \text{ N}$
 $(F \cdot L)_{\max} = 1536 \text{ Nm}^{3)}$
 $f \approx 0,7 \cdot 10^{-12} FL^3 + 0,5 \cdot 10^{-9} FL^2$
 Ex. $F = 100 \text{ N} ; L = 1000 \text{ mm} \rightarrow f \approx 0,1 \text{ mm}$

Profile 90 x 90 mm (90 x 180)

Virtually equivalent to two parallel 45 x 90 mm (45 x 180) profiles

*1) Value before the appearance of the first signs of sliding under the corner triangle.

1) Profiles N 0275 and N 0276 : These light profiles can be assembled only onto their slotted faces and their front section. For the mounting methods A31, A21, A32, A22 the elastic limits $F_{A \max}; F_{\max}; (FL)_{\max}$ approach the corresponding values of the other profiles, the deflection f_2 , due to the lower of inertia is $\approx 10...20\%$ higher.

2) Profiles N 0275 and N 0276 : No corner triangles can be mounted on the closed face of these light profiles.

3) The torque FL is limited by the compression resistance of the profile at point P (13 kN)

Type of fault	Safety factors currently used in mechanics
Permanent deformation (exceeding the limit of elasticity)	S = 1,2...2
Static rupture	S = 2 ...4
Dynamic rupture (Fatigue)	S = 1,5...3
Instability (Buckling)	S = 3 ...5

Safety Factors : The safety factors to be applied usually depend on the type of machine, the accuracy of the calculations and the class of danger in case of catastrophic failure. Some values currently applied are indicated in the table opposite. Should the failure present a possible danger for people, the safety factor to be selected may be much higher.

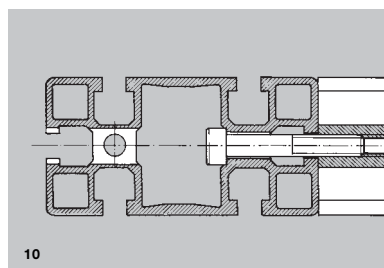
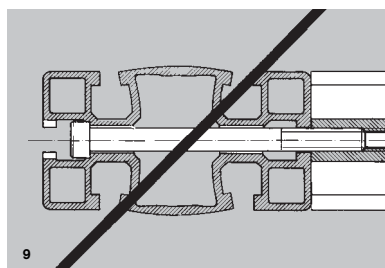
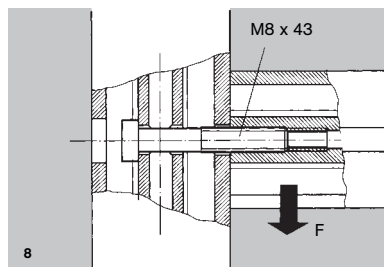
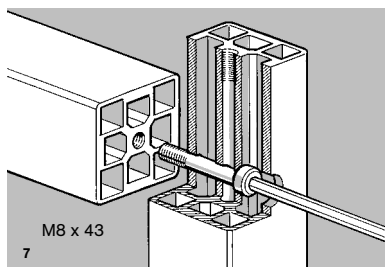
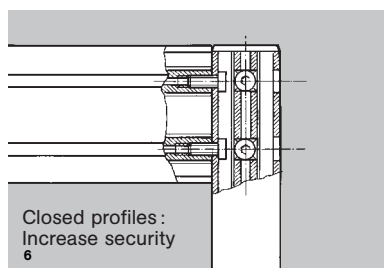
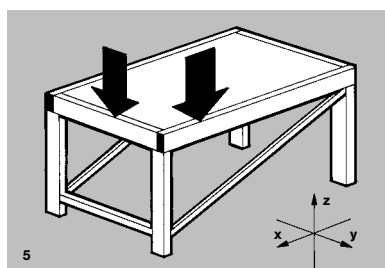
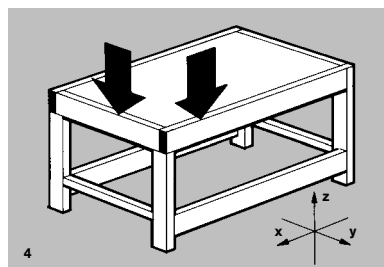
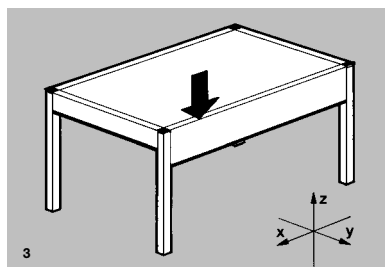
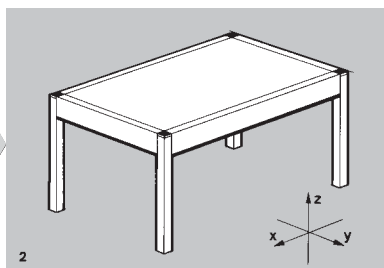
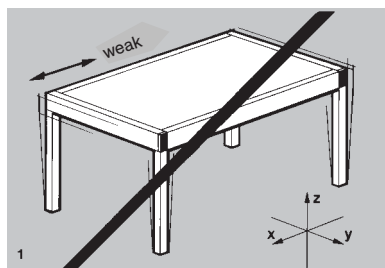

Stiffness : As a rule, a structure of given dimensions can be constructed with NORCAN profile in different design formats. The different designs do not provide the same stiffness or load bearing capabilities.

Example: a table of 1 m x 1.5 m x 0.75 m, load 3 kN.

The first solution (fig. 1) uses a support frame for a plate made up with 45x90 NORCAN profiles fixed on legs in 45x45 profiles with 1 M8 screw per leg. In case of horizontal thrust in direction x, this connection will be stressed in the least favourable manner with a great deal of flexibility and have a tendency to vibrate.

In the second solution (fig. 2), the legs of the table are embedded in the plate support frame and fixed with 4 screws each providing a significantly higher stiffness (see also calculations on page 74 and 75).

For very high loads we recommend solutions alike fig. 3...5.

Through Bolt : In case of applications under stress, the mounting with the M8x43 through-bolt will offer the following benefits:

1. Mechanical resistance (see tables p. 74 to 75): as the bolt rests, in this solution on the web of the profile, permissible values for the shear force F_A and the moment FL are notably increased.
2. Stiffness: The stiffness of the mountings with a through-bolt is virtually double of those with M8x20-screws. For the same load, the elastic deformation will be limited to approximately half.
3. Safety: Certain safety requirements demand, that an element whose fixing screw becomes loose must nevertheless remain secured. (fig. 6, 8, 10).

Attention! As the screw is stressed in deflection in this application when using slotted profiles, make sure that absolutely accurate calculations of the permissible static and dynamic loads are performed (As a guide: static load will be around 1 kN per screw, dynamic load is of course lower than that). We therefore recommend in this case the use of **closed profiles** given that if the load slides on the screw the limiting factor will be the shear stress (fig. 6 and 8).

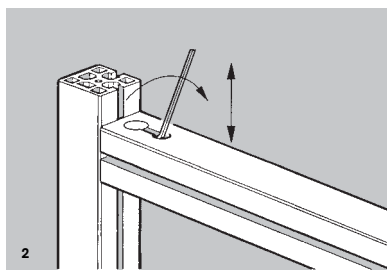
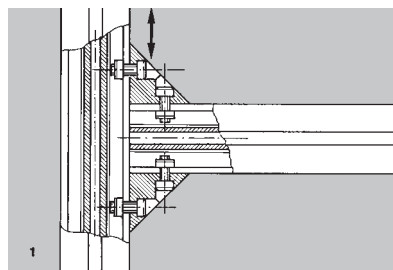

Adjustable mountings: Mountings with central bolt allow a limited adjustment only. For longer adjustments, we recommend:

- firstly make a mounting with corner triangles and secondly a mounting with a central screw (fig. 1).

- to assemble with assembly nuts N 1140 (fig. 2).

- to mount with adjustable coupling "T" - N 1149 (fig. 3).

Fig. 4 and 5 show mountings with the adjustable coupling "X" - N 1148 and the assembly plates N 1110 or N 1111.

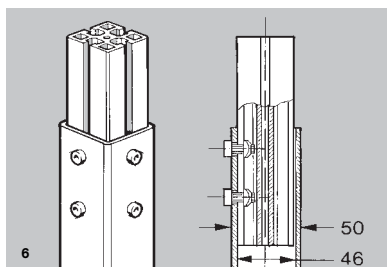
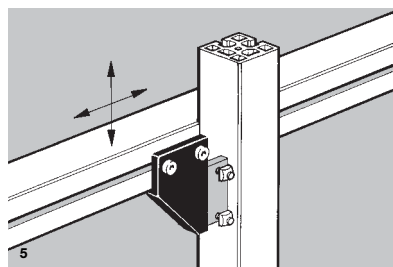
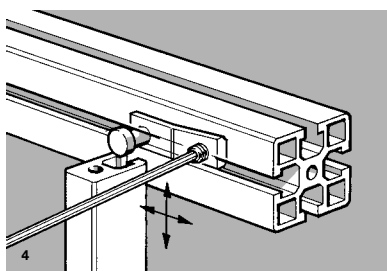
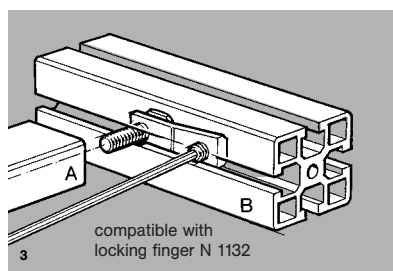

Telescopic mountings: standard 50/46 square tubing can be used for the construction of table legs, cantilevered mountings, and other telescopic or sliding mountings. The fixing is made with two pairs of nuts at 90° (do not position the screws across the axis of the profile - danger of deformation!) (fig. 6).

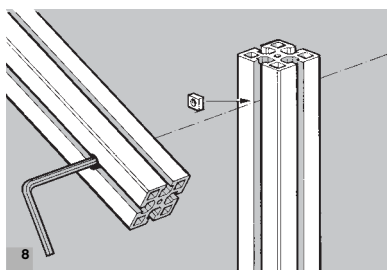
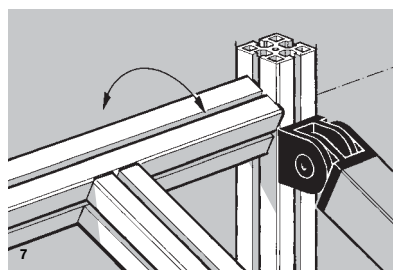

Orientable mountings: Assemblies with nuts and bolts allow the construction of orientable structures. With a fixed rotation axis, use a SC nut and a M8x43 screw (fig. 8). With a sliding rotational axis the assembly with 2 or 4 corner triangles (fig. 10) or with the adjustable coupling "X" (fig. 4) will give a possibility of movement in 2 directions.

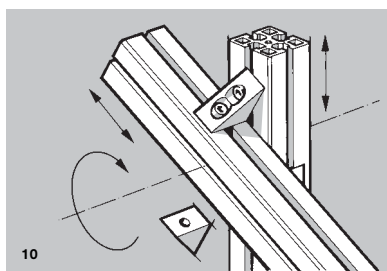
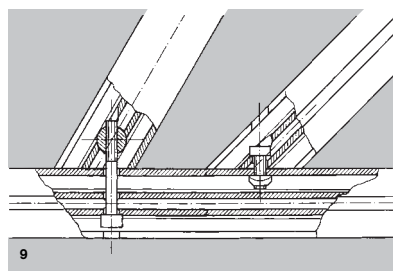

Angled mounting (fig. 9): Profiles cut at an angle of 45° can be assembled directly using a M8x20 screw and a M8 SC nut. For all other angles use the angled assembly coupling N 1145.

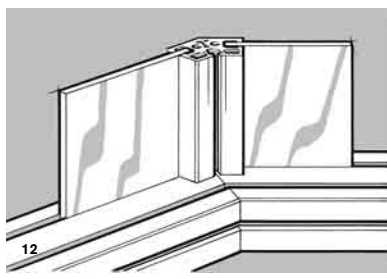
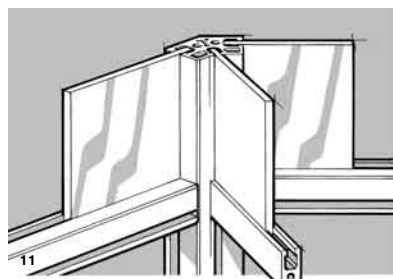

Angles of 45° (135°) on safety housings: The NORCAN profile 31,5/45° - N 0195 enables profiles and panels to be joined at an angle of 135° (fig. 11/12).

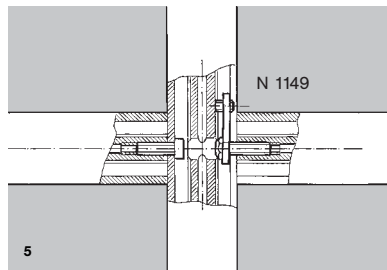
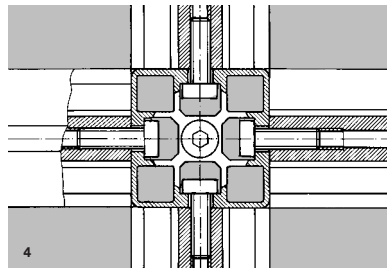
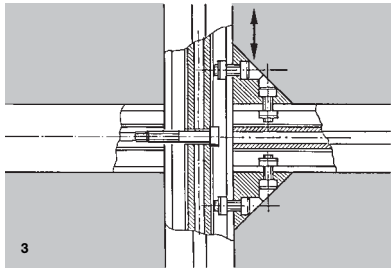
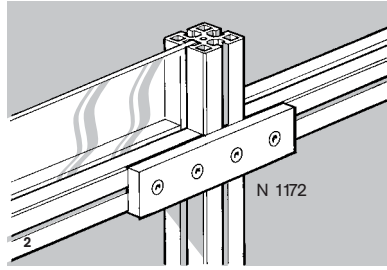
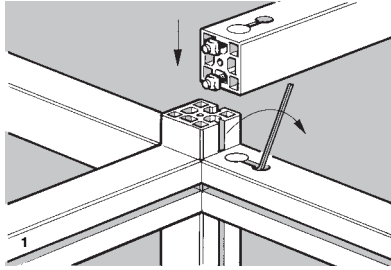

Cruciform mounting: For the very few cases where a cruciform mounting is necessary, we offer the following solutions :

- Assembly nuts N 1140 (fig. 1).
- Assembly with a 12x45x180 plate N 1172 (fig. 2).
- Assembly with corner triangles (fig. 3).
- Assembly with the 5-directional block N 1125 (fig. 4).
- For special applications we dispose a certain number of cruciform mountings with central screws almost invisible from the outside. Details on request.
- Assembly with adjustable coupling "T" N 1149 (fig. 5).

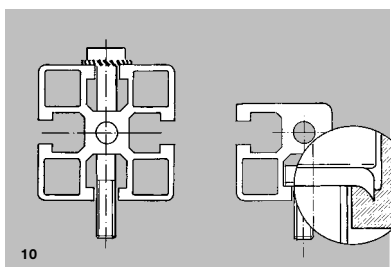
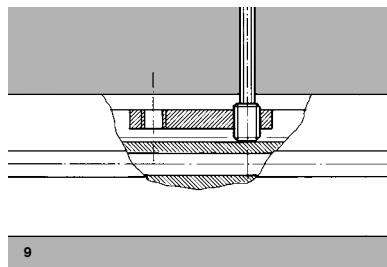
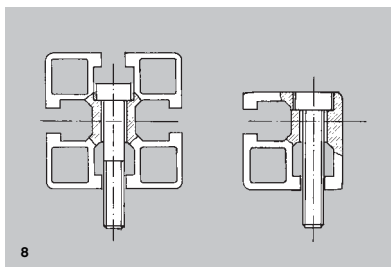
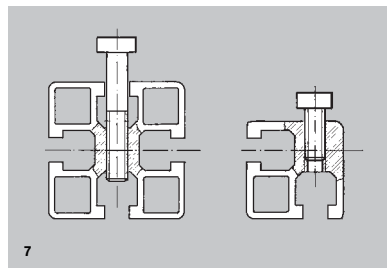
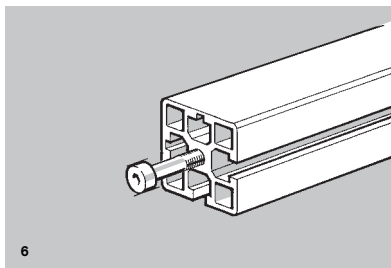

Electrical continuity

Aluminium profiles, fasteners and metallic accessories are good conductors and the contact surface of screws and **un-anodised** aluminium provides good electrical continuity.

The surface layer of anodisation is however, an efficient insulator.

Electrical continuity between profiles and fastener is normally achieved through :

- tapping into profiles (fig. 6 and 7).
- counterboring of the profiles into the profile core (fig. 8)
- the head of bolts and nuts with an electrical continuity washer, N 3356, in the profile slot or any anodised face (fig. 10).
- all joints using grubscrews and tightened on the bottom of the profile slot (fig. 9 and similar).

For other types of assembly where a bolt head or nut is mounted on an anodised face use a serrated washer or an electrical continuity washer N 3356 which enable electrical continuity by piercing the anodisation layer (fig. 10).

Please note that hinges only provide weak electrical continuity. An earth connecting wire should be used.

Important : on request we can supply our aluminium profiles with conductive "ALODINE" finish

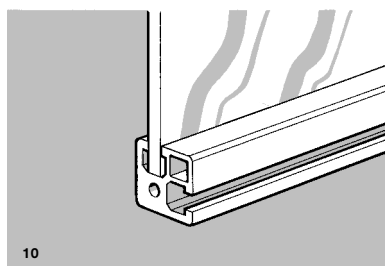
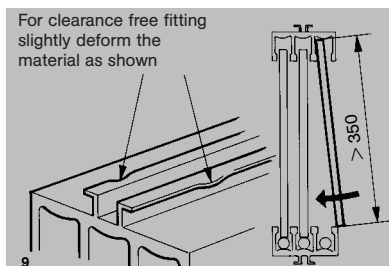
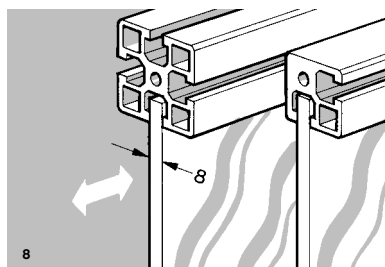
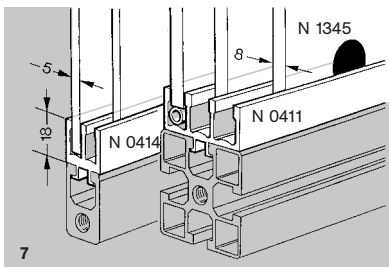
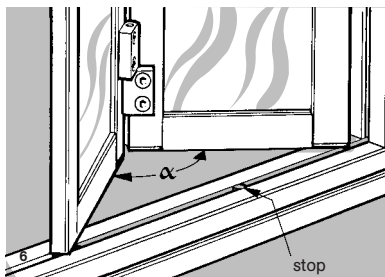
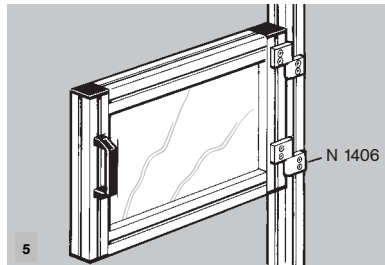
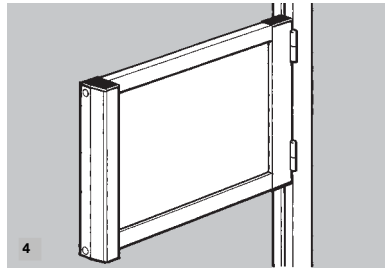
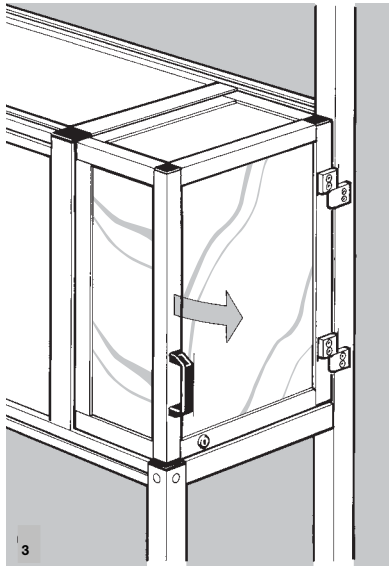
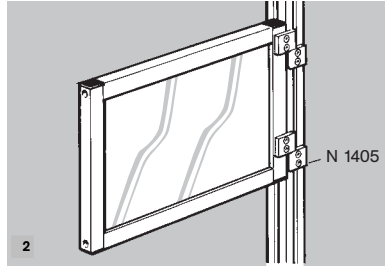
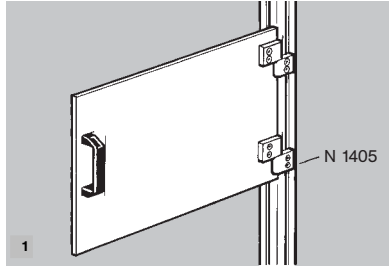

Doors and windows of moderate size (up to about 0,2 m², not subject to vibration) can be completely fabricated in organic glass or transparent plastic (acrylic "Plexi", PVC, polycarbonat, PS, etc., fig 1).

For window panes of intermediate size (up to about 0,6 m² we recommend a frame in 31,5x18 mm NORCAN profiles. (fig. 2 and 4).

Doors and window panes exceeding 0,6 m² as well as doors under stress or subject to vibration must be framed with 31,5x31,5 mm to 45x90 mm NORCAN (fig. 5).

Tilting housings or hoods should preferably be made in 31,5x31,5 NORCAN profile whose low weight and absence of apparent slots offer significant benefits in the safety housing field (fig. 3).

Folding doors : Foldings doors are easily made using hinge elements. The angle α between the two doors must not go below 20° so as to not overload the hinges and pins. (Folding doors supplied ready assembled are fitted with a stop).

Sliding doors and windows :

4 to 5 mm sliding windows in organic glass of moderate size are mounted in N 0413 2 tracks profiles (fig. 7).

Windows panes in organic glass as well as sliding doors 8 mm thick are to be mounted :

- directly in the slot of the NORCAN profile (fig. 8, 10)
- using a N 0411 3-track profile or its N 0412 2-track version (fig. 7). Insertion of 8 Ø N 0517 tubing in the lower slot will allow removal of the pane without dismantling the frame.

For smooth and silent sliding we recommend the use of N 1345 pads for sliding doors (fig. 7).

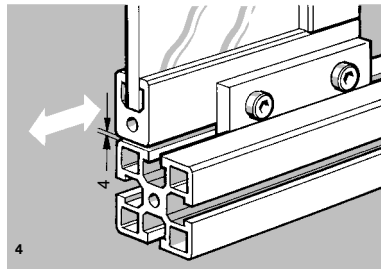
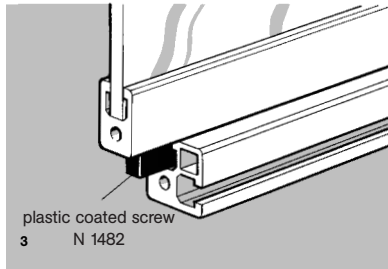
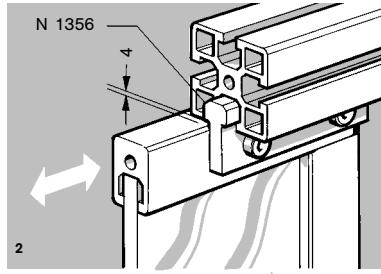
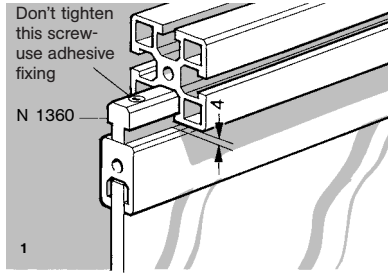

Sliding doors and windows framed with NORCAN profiles, whose weight is supported by the upper guide are to be mounted as follows :

- in the slot of the upper guide via a N 1360 or N 1356 profile (fig. 1 & 2).
- in the rail N 0820 (page 34).
- in the slot of the lower guide on a 8 mm strip in polyamide, polyacetal or polyethylene (fig 3 & 4), on the guiding pad on M8 screw N 1348 (page 33) or on the retractable guiding finger N 1480 (fig 9 and 11).
- on the double door rail N 0820 (p 46).

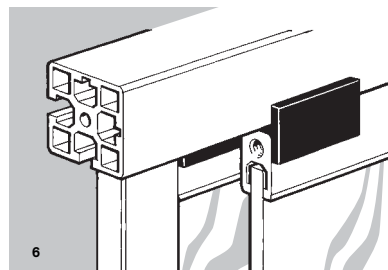

Sliding doors and windows framed with NORCAN profiles, whose weight is supported by the lower guide are to be mounted as follows :

- on polyethylene H-shaped guide profile N 1362 (fig 6 & 8).

Attention! taking out a sliding door requires disassembling of the upper aluminium rail. For easy removal, we recommend an upper guide made of the guide profile 3 tracks N 0411 and 4 guiding fingers N 1480 which can easily be pulled back after loosening the locking screw (fig. 9).

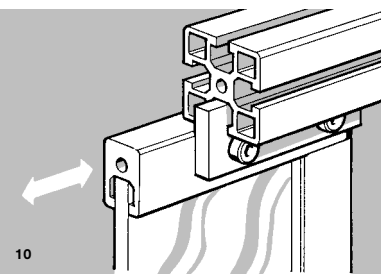
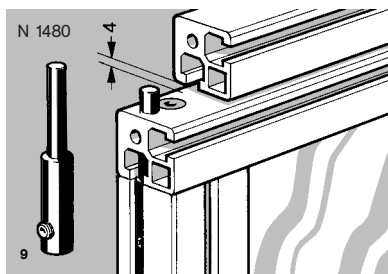
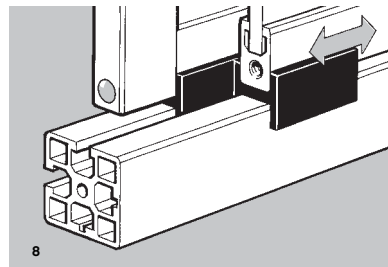

- in the upper guide slot on an 8 mm strip of polyamide, polyacetal or polyethylene (fig 10).

- in the lower guide on slot on an 8 mm strip of polyamide, polyacetal or polyethylene which may be supported by bearings for smoother operation (fig. 12).

For frames and sliding windows in 31,5x31,5 mm and 31,5x45 mm profiles, N 1315 guiding rollers are mounted in a counterbore.

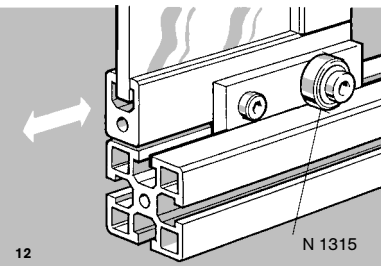
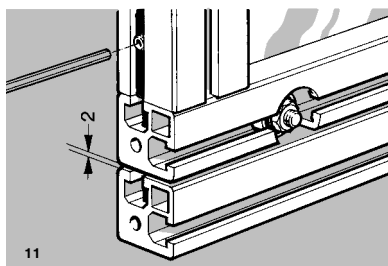

Sliding frames which are easily removable are guided laterally by the polyamide guiding finger N 1480, which can be pulled back after loosening the locking screw (fig 9 & 11).



Modular security screen for enclosing security areas.

Upright (fig 3):
 Height: 2000 and 1600 mm
 Profile: 45 x 45 mm
 With mounting foot and 4 screws
 M8 x 20.

Frame (fig 4):
 Height: 1800 and 1400 mm
 Width: 500, 750, 1000, 1500 mm
 Profile: 18 x 31,5 mm;

Panels available:

- Beige melamine 8 mm thick
- polycarbonat transparent or smoked 5 or 8 mm thick
- Aluminium anodised, 2 mm
- Wire mesh, welded, 40x40, in painted, zinc coated steel or anodised aluminium wire.
- Glass laminated 6,3 mm thick
- Other panels on request.

Door (fig 5):
 Height: 1800 mm
 Width: 1000 mm
 Profile: 31,5 x 31,5 mm and 31,5 x 45 mm with hinges, screws and handle N 1444.

Options:

- Ball latch
- Door handle N 1425 - with key.
- safety switch like SCHMERSAL AZ 16 - 12 ZVRK 30 N with brackets.

Panels of doors like the frames shown above.

Important: The doors are delivered without uprights but with the higher door strut.

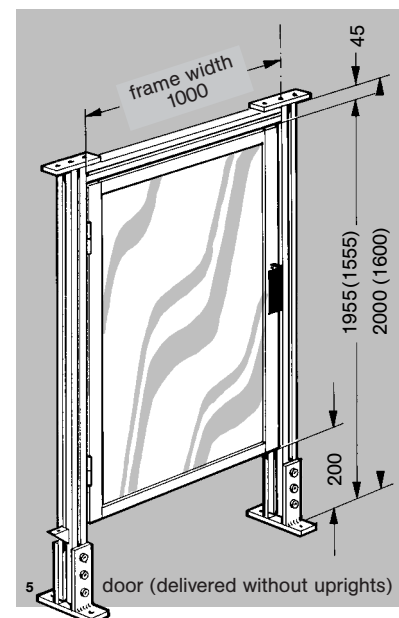
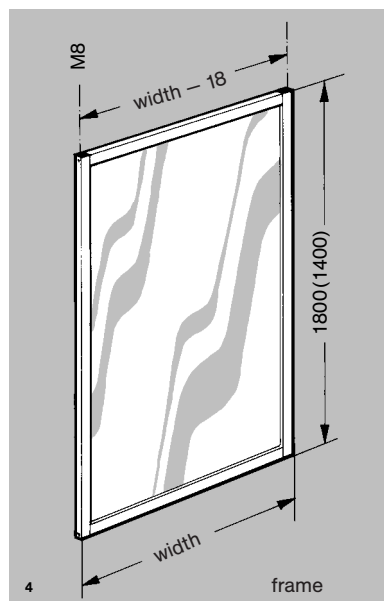
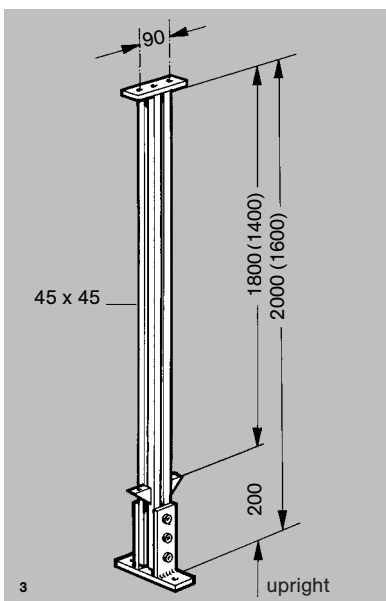
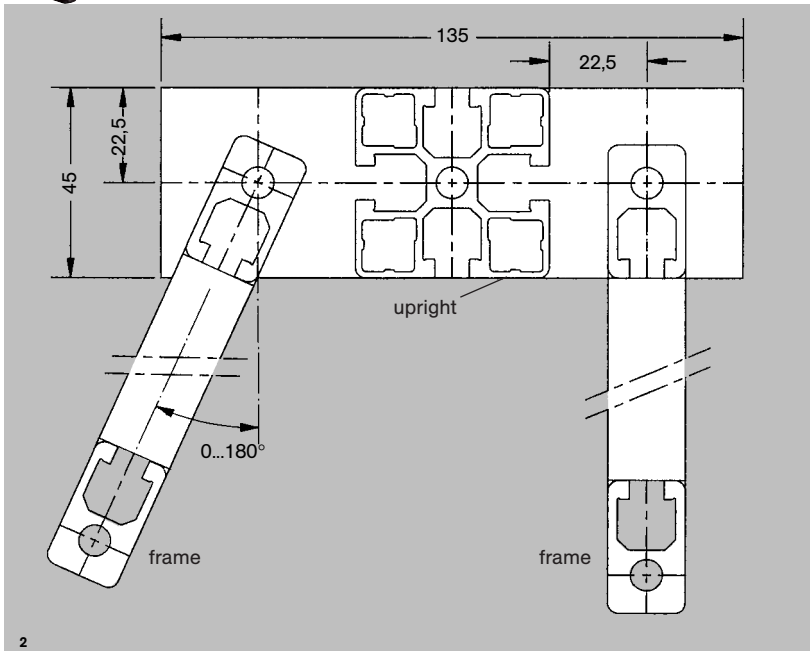



Workstations of modular design permitting many different combinations to be realised.

- Work surface in different material: chipboard, plywood, melamine or for the electronic industry antistatic and the solder resistant.
- Parts transfer using an integral conveyor (see opposite). We can also install ultra thin conveyors.
- Framework dependant on the load : standard, heavy, vibration resistant.
- Feet fixed, adjustable, with castors, telescopic.
- Conduit for electrical cables.
- Integrated pressurised air distribution.
- Lighting including individual spot lights for the working area.
- Trays, document supports etc. on articulated arms.
- Shelves adjustable in angle and height
- Integral draw units.
- Integral, adjustable foot rests.

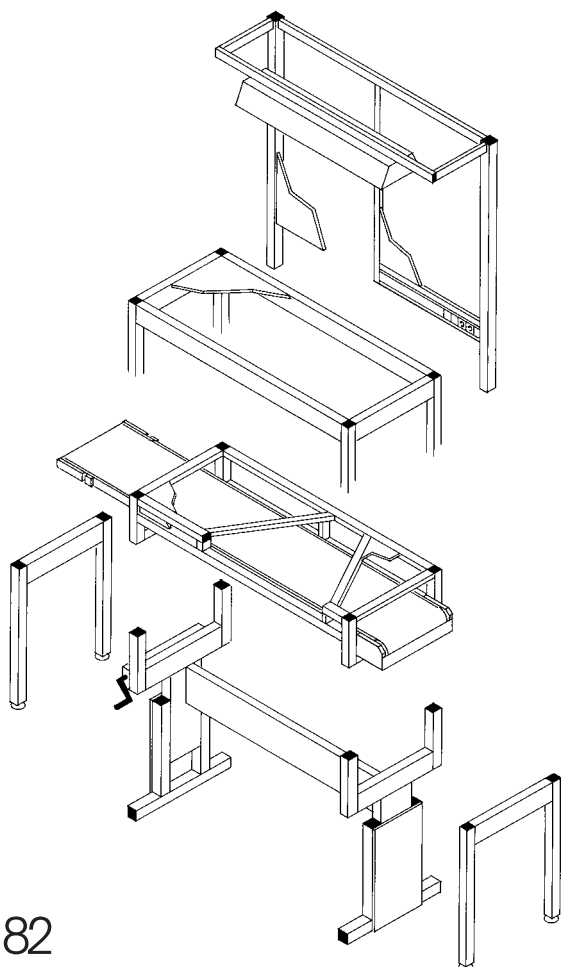



NORCAN rotobox is a new type of ergonomic workstation designed to increase productivity.

NORCAN rotobox has a 4 position rotary magazine, it can be re-charged without disturbing the operator.

NORCAN rotobox simplifies the management of stock which is key in any ISO 9000 system. Access is protected by security switches and the housing gives effective dust protection.

Storage capacity: 4 magazines of 5 boxes plus 1 accessory shelf.

Dimensions : Width 1,3 m. Depth : 1 m. Height : 1,3 m

Power supply : 400/415 V three phase (on request 230/240 V single phase).

Additional equipment : belt and roller conveyors, lighting and work surfaces.

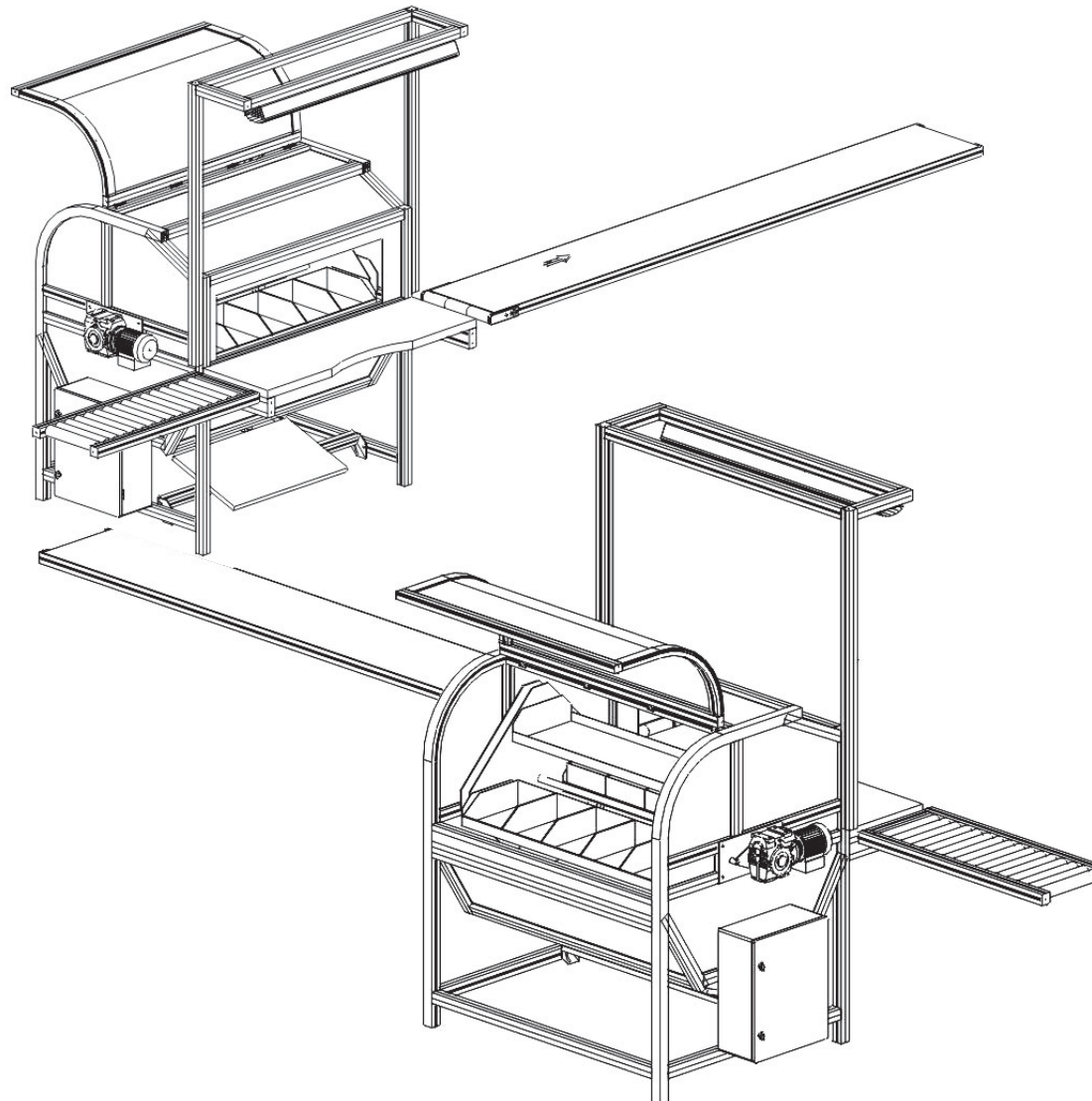



NORCAN furniture, with a clean and functional design, are made of an anodised aluminium structure, with no visible fixing slot, together with a large selection of panels and glass panels.

The profile assembly system designed for machine frames, gives this line of furniture a solidity which makes them suitable for both workshop and office.

Standard → made to measure

Made to measure by NORCAN is simple; in the catalogue, each piece of furniture is shown by a photo and a dimensioned 3D design; you need only make a photocopy and note your specifications and dimensional changes to allow your commercial service to send you a price and CAD 3D drawing.

Delivery condition

Assembled, packaged or in kit, dependant on size and customer requirements.

Machines frames and housings

Since the "CARENAL" furniture range is based on the NORCAN system, the combination of the two ranges assures the aesthetic and technical unity of workshop and office workstations.

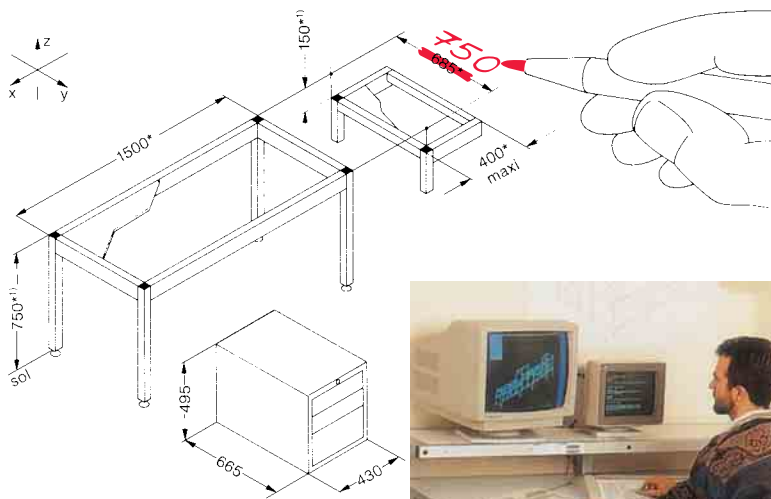

* these dimensions may be modified

1) measured from worktop surface



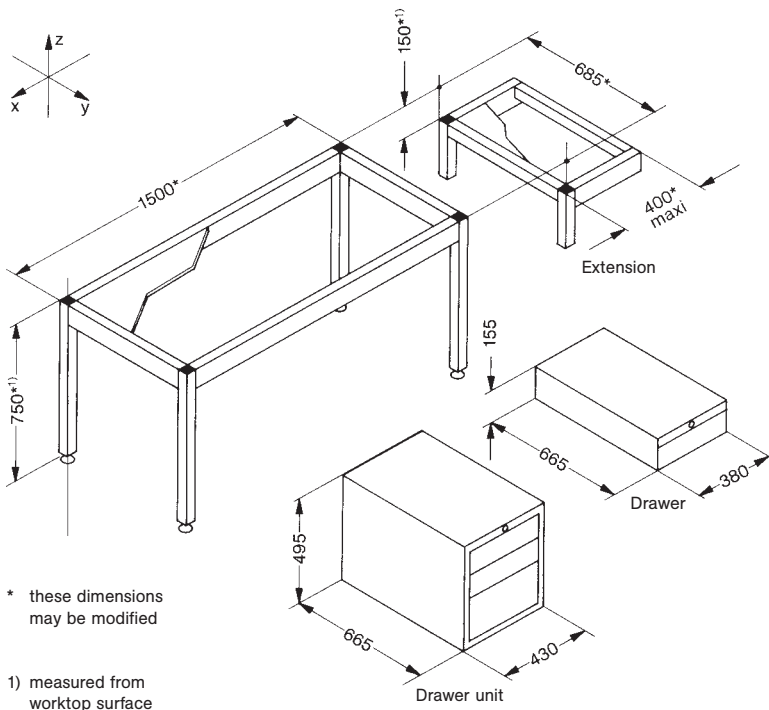

These tables of high aesthetic and mechanical quality are suitable for use in workshop and office and are available in several versions :

Standard table(s) with dimensions as shown opposite with 4 legs with 15 mm adjustment, 19 mm recessed worktop in chipboard finished in beige melamine, without drawers or extensions.

Made to measure tables : * modify the dimensions marked* on a photocopy of this page.

Extension : width and type of workshop same as table worktop.

Structure according to load : standard - heavy - vibration.

Workshop suitable for required application.

3 metal drawer unit as shown opposite (Special build : wood, made to measure etc... on request). Specify if drawer unit is to be fitted on left or right hand side of the table.

Metallic drawer as shown opposite.

Worktop range (identical for all CARENAL furniture)

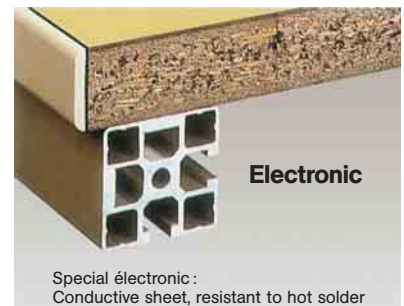

NORCAN office and workshop trolley

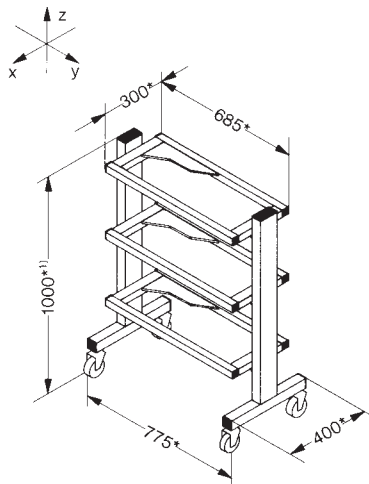

* these dimensions may be modified

1) measured from worktop surface

Trolley with shelves which may be adjusted in height, depth and angle for office and workshop use :

- for printers and tracers
- for measurement and inspection equipment
- with angled shelves: to hold parts boxes.

Standard version as shown opposite with 3 edged shelves in 8 mm chipboard, finished beige melamine , mounted on castor wheels.

* Made to measure version: note specifications and dimensional modifications on a photocopy of this page. Attention! Specify the number of shelves together with the dimensions of each one.

NORCAN drawer unit

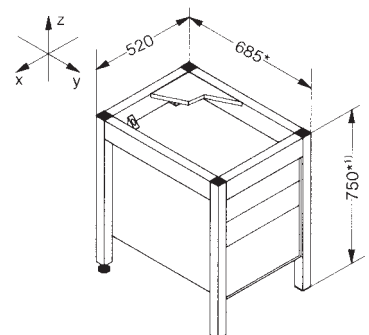

High aesthetic and mechanical quality drawer unit in several versions for both workshop and office.

Standard version as shown opposite with recessed 19 mm chipboard worktop, finished in beige melamine, and metallic 3-drawer unit.

* Made to measure version: note specifications and dimensional modifications on a photocopy of this page. Any vertical panels will be in 8 mm beige melamine chipboard.

Drawer unit in other size or to measure in wood / chipboard

On 4 rotating castor wheels, 2 braked.

* dimensions may be modified (made to measure)

1) measured from worktop surface.

NORCAN

auxiliary table (secretarial, instruments...)

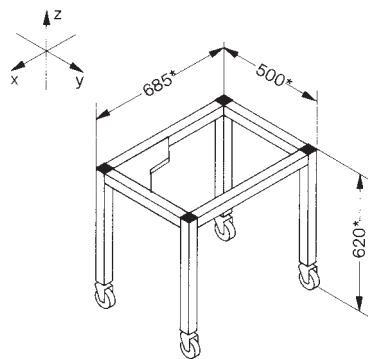

* dimensions may be modified (made to measure)

High aesthetic and mechanical quality small table available in several versions:

- * Standard version as shown opposite with recessed top in 19 mm chipboard finished in beige melamine.
- Made to measure version: note specifications and dimensional modifications on a photocopy of this page.
- Structure according to load: light - heavy - vibration
- Special legs with 400 mm adjustment

NORCAN

small unit to support photocopier or other equipment

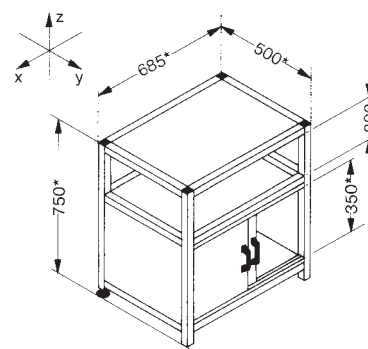

* dimensions may be modified (made to measure)

This unit makes functional use of the area actually occupied by your photocopier, fax, laser printer etc...

- * Standard version as shown opposite with recessed surfaces in beige melamine finished chipboard 19 mm. Vertical panels in same material, 8 mm thick.
- Made to measure version: note specifications and dimensional modifications on a photocopy of this page.
- Worktop in 8 mm polycarbonat (specimen on the photo).

NORCAN

movable adjustable partition walls for office and workshop

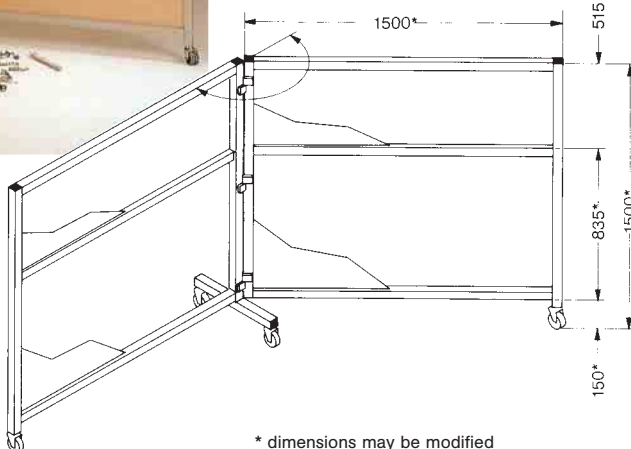

* dimensions may be modified (made to measure)

To protect from projections of liquids, chips etc... and to partition off e.g. metrology or mobile inspection areas.

- * Standard version as shown opposite with lower panels in 8 mm chipboard, finished beige melamine, and glass panels in 5 mm polycarbonat.
- Made to measure version: note specifications and dimensional modifications on a photocopy of this page. for panels and glass panels, see below.
- Panels in 8 mm chipboard, finished in beige melamine
- Panels in 8 mm hard PVC on PVC foam centre, blue. Water and oil resistant.
- Glass in 6 mm mineral multilayer glass "TRIPLEX" type.

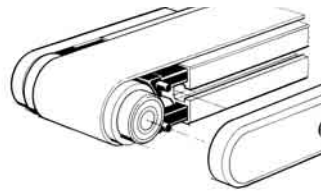

ø 20 mini belt conveyors :
small, but good load capacity. Width: 45... 256 mm and larger. Length to suit.
Geared motors: 400 V , 230 V three phase, 230 V single phase with speed controller and 24 V DC brushless mini-motors.

All our belt conveyors have the NORCAN safety system



ø 50 standard belt conveyors :
with practically all types of belts: PVC, PU, silicone, felt type for sharp edged pieces.
Width: 45... 606 mm and larger. Length to suit.
Geared motors: 400 V , 230 V three phase, 230 V single phase with speed controller and 24 V DC brushless mini-motors.



ø 95 heavy belt conveyors : for heavy loads.
Width 306... 806mm (up to 2000mm on request!)
Length to suit.
Geared motors: 230/400V three phased



Mesh belt conveyors :
ideal for wet and oily pieces (dripping and drying) and accumulation.
Width: ≈ 100mm upwards.
Geared motors 230/400V.

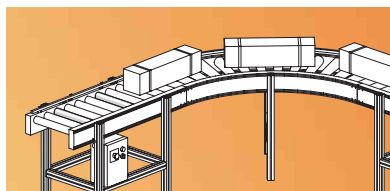

Roller conveyors :
for parcels, containers and panels.



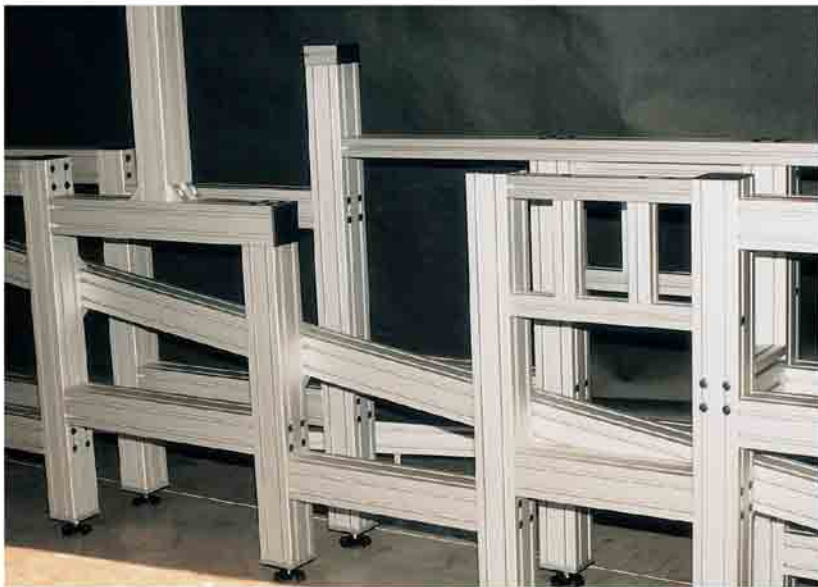

Frames and workstation: The two examples on the top of the page show safety housings incorporated into the machine frame.



Precision frame : This frame was part of an assembly to finely adjust very heavy components.

The design in large section profiles and the incorporation of aluminium plates in the structure gave this assembly exceptional rigidity.

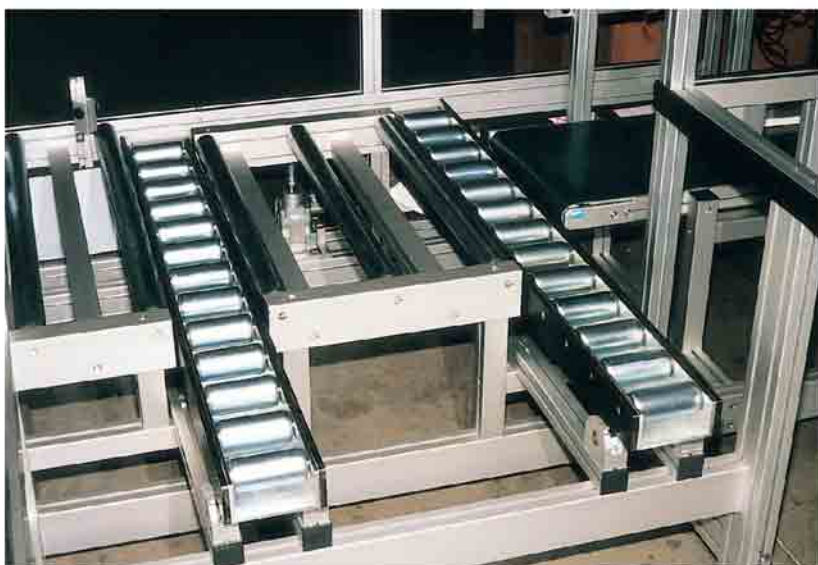

Automatic packaging line with frame made of half-closed profiles and NORCAN conveyors.

NORCAN conveyor with central drive and adjustable frame made of $1/2$ closed profiles.



Automatic station : This unit is an integrated part of an automatic electric component assembly line. The internal frame, actuated via a small air cylinder, slides on standard strips along the grooves in the external frame as detailed on page 36.



Large machine frame : The judicious use of closed and half closed profiles resulted in a structure of high torsional rigidity allowing shipment of the fully assembled structure.



Feeding of a centerless polisher : Here, the use of slotted profiles has allowed us to easily make a number of settings and adjustments simply by interposing a guide strip N 1350 in opposed slots of two adjacent profiles (see diagram below).

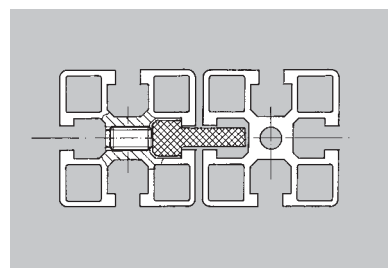

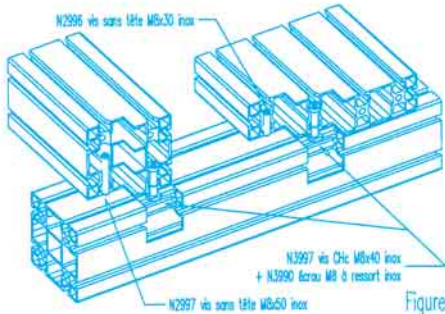

Figure

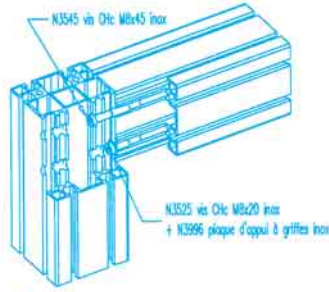
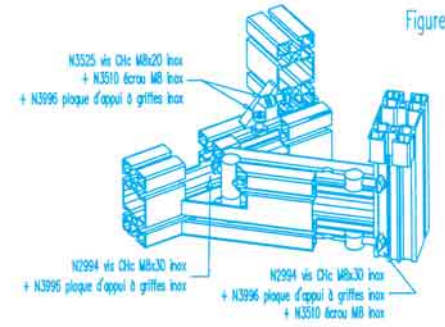

Figure 2



Figure

Figure 3



11 m long and 5 m high structure supporting a total load of 3,8 tons on the linear guides of the upper horizontal profiles.

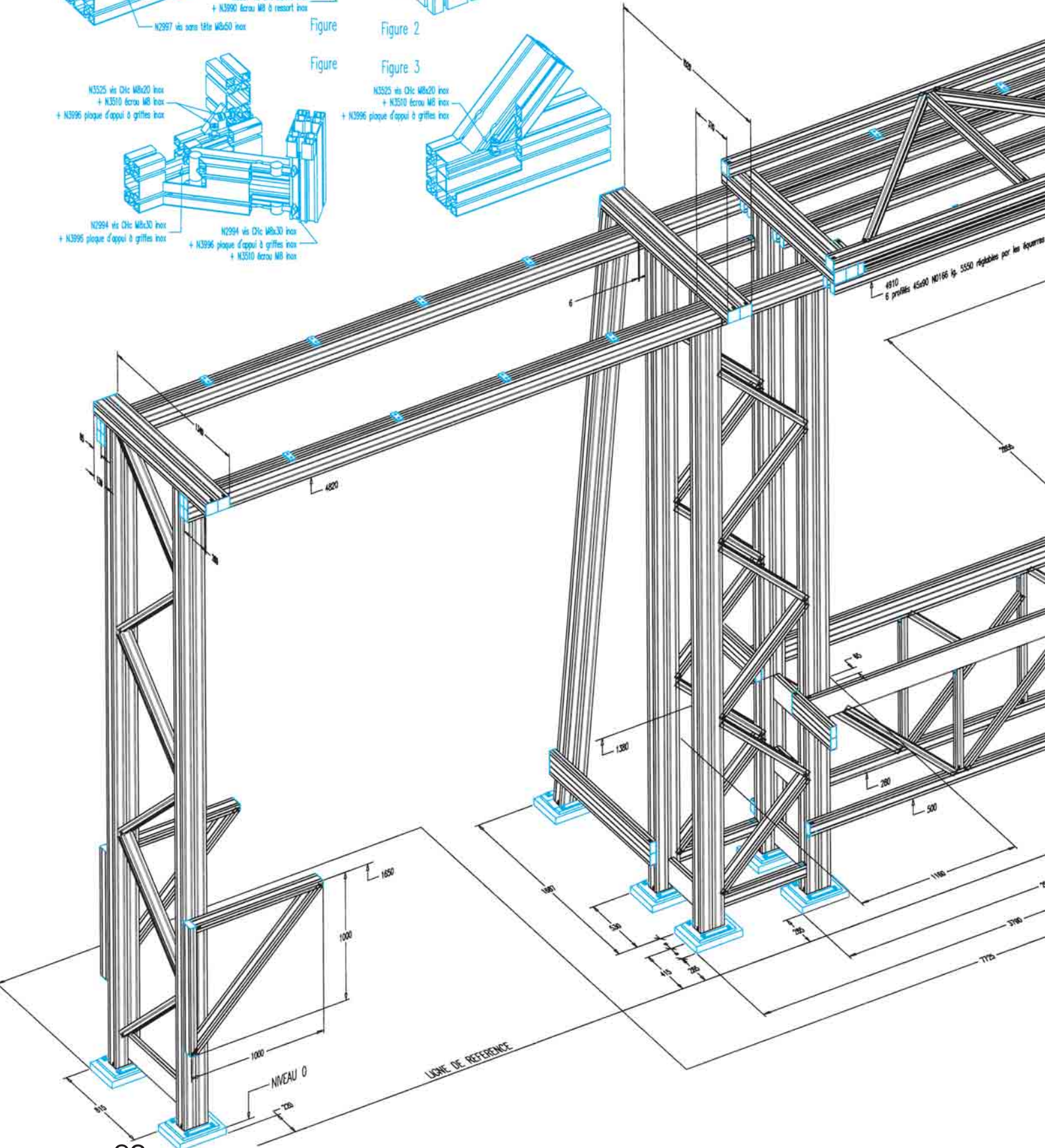

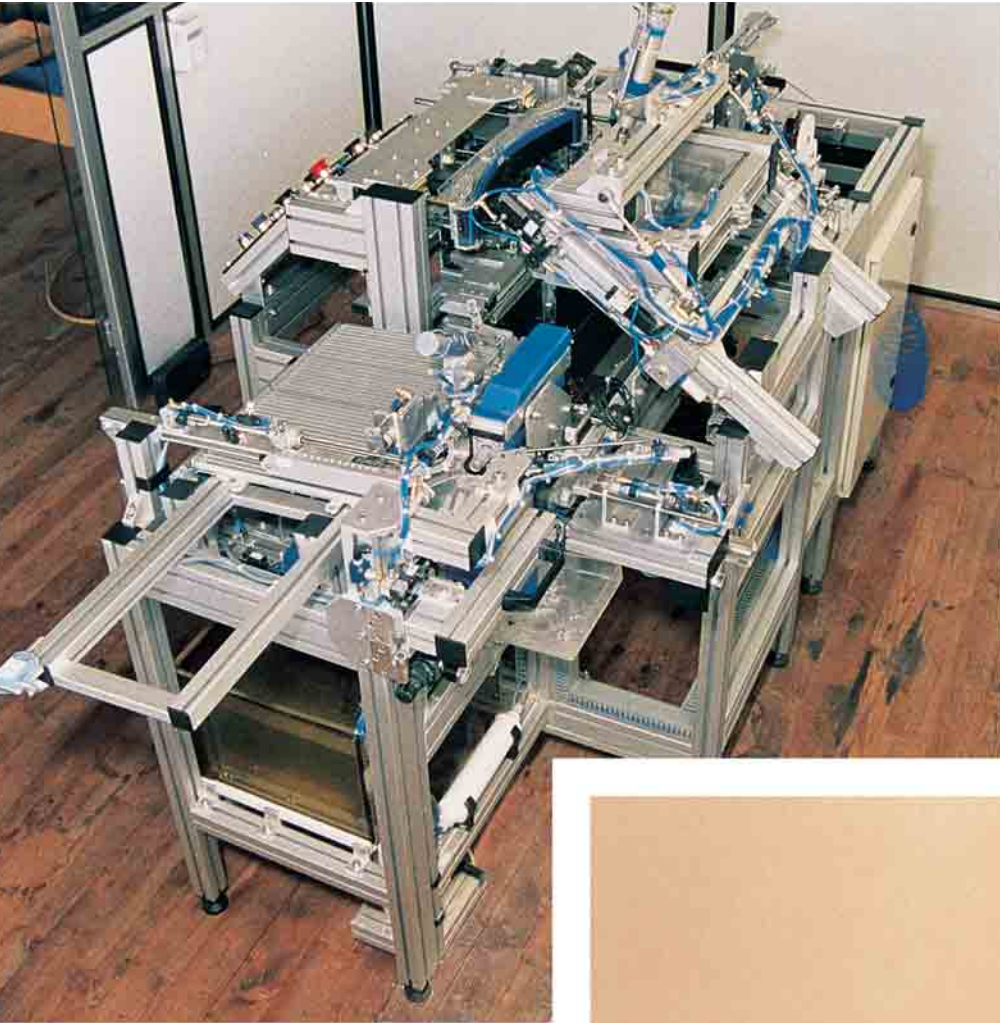

Production unit for dental mirrors

Rigid framework for vibratory bowl feeder.



Moveable work station : with hydraulic level adjustment and horizontal table on smooth guides and NAP 57 with lock.

Frame vertically mounted with a carriage running on guide blocks and driven by a trapezoidal screw and bevel gear box.

Moveable work station : The use of counterweights allows the operator to adjust the height level manually with minimal effort.

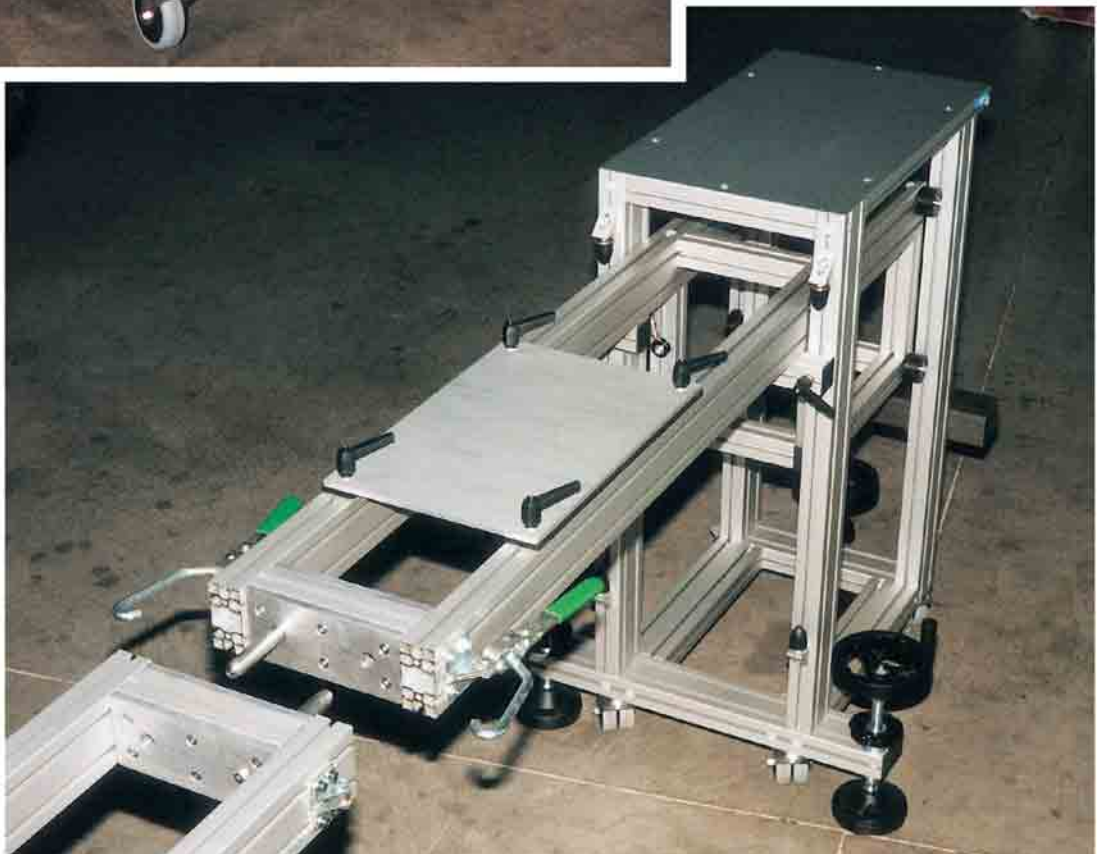

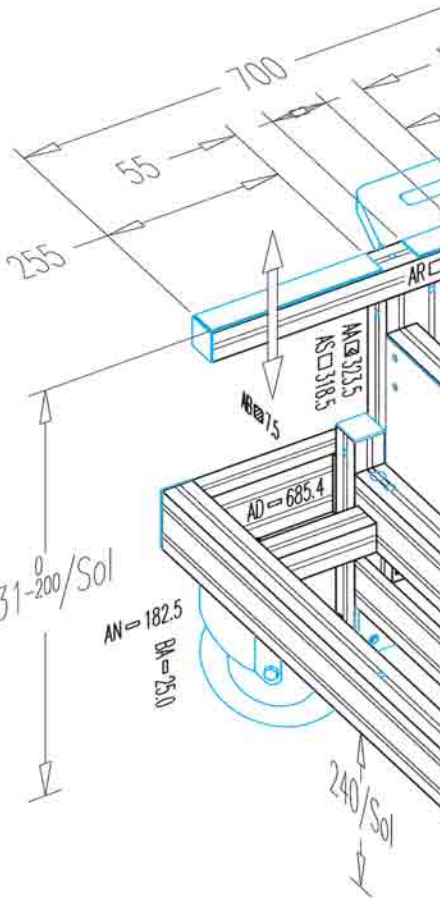
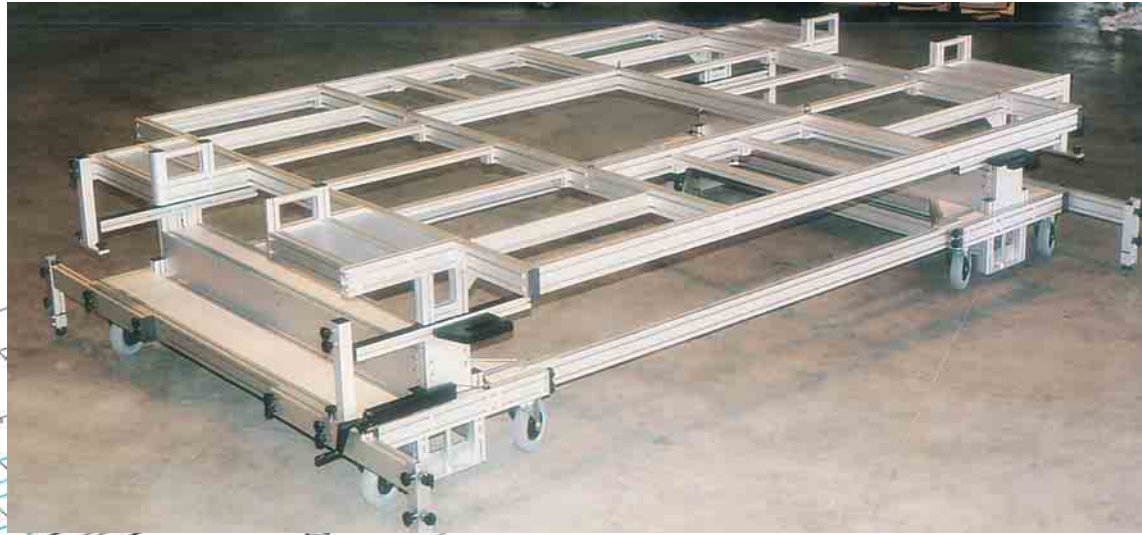

Modular frame with hydraulic level adjustment for the transport and machining of large panels and metal sheets.

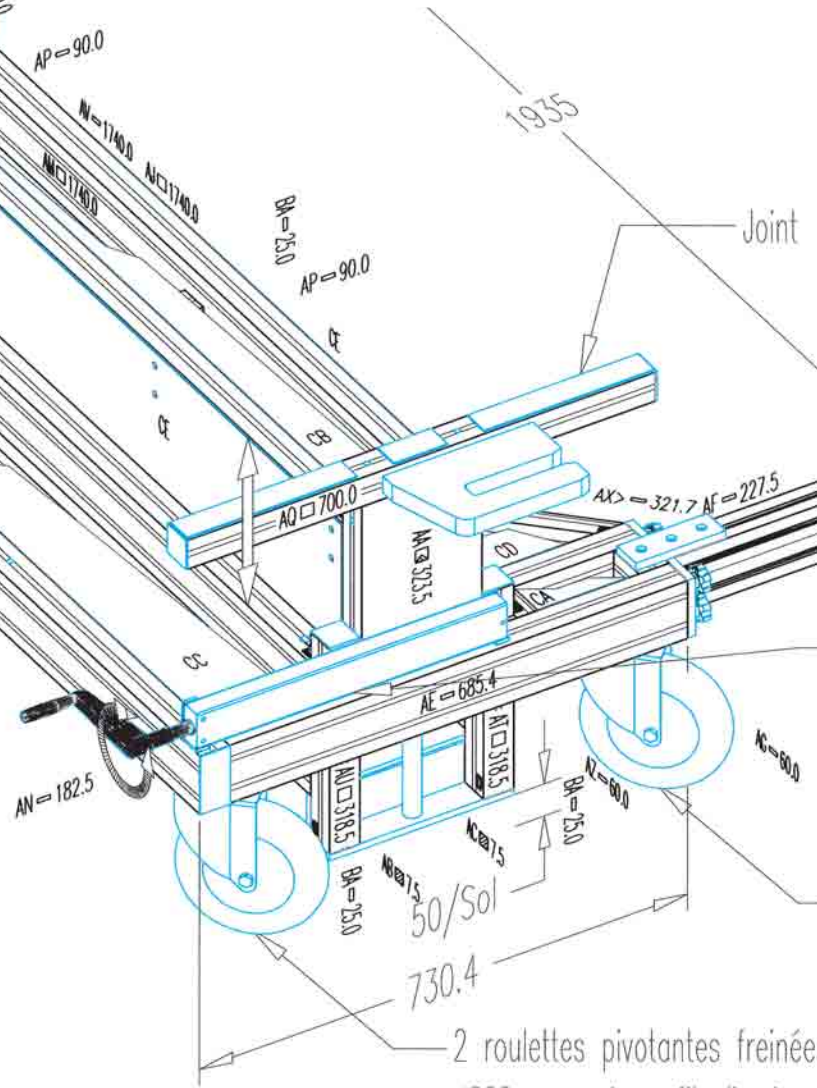

2 roulettes pivotantes freinée
 Ø200, pneu à profils lignés
 avec chambre à air.

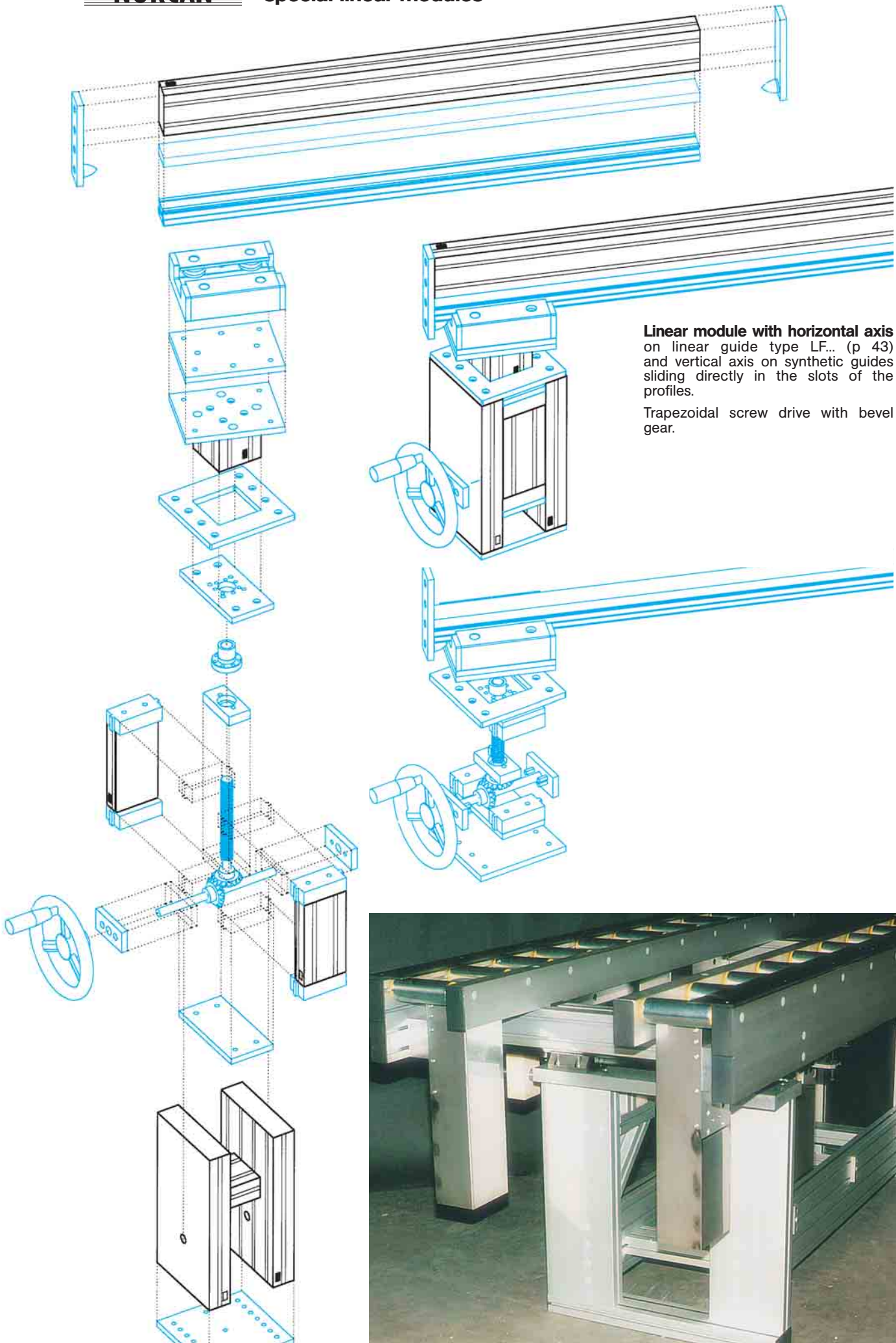

Linear module with horizontal axis
on linear guide type LF... (p 43)
and vertical axis on synthetic guides
sliding directly in the slots of the
profiles.

Trapezoidal screw drive with bevel
gear.



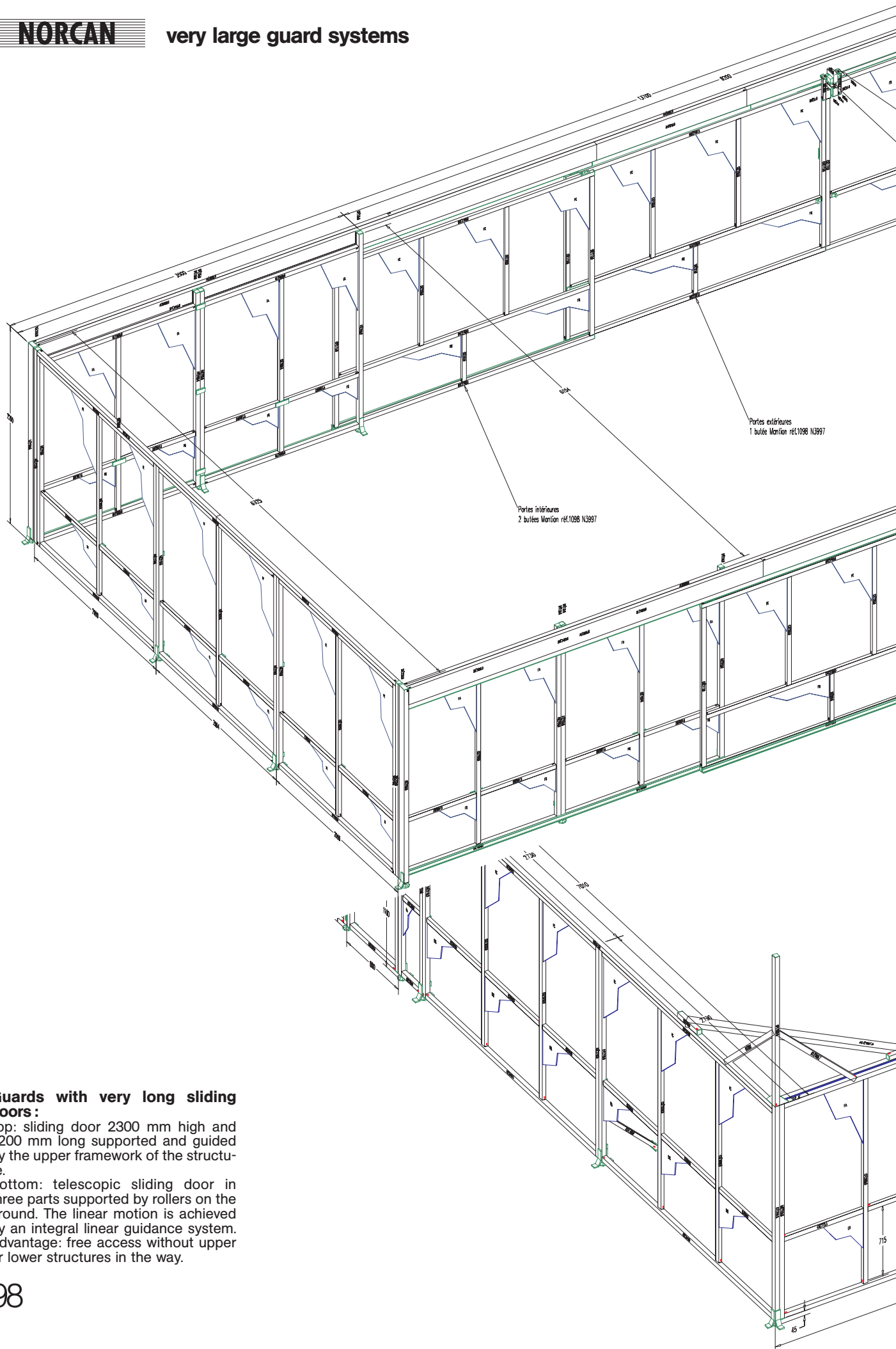

Guards with very long sliding doors:

Top: sliding door 2300 mm high and 4200 mm long supported and guided by the upper framework of the structure.

Bottom: telescopic sliding door in three parts supported by rollers on the ground. The linear motion is achieved by an integral linear guidance system. Advantage: free access without upper or lower structures in the way.



Semi-automatic assembly, inspection and packaging station, with NORCAN frame, housing and conveyor.



Work station for assembling and the computerised inspection of precision guide rails.

NORCAN application examples



Above : safety housings using polycarbonat panels (above left) or mesh panels (above right).

Maintenance and repair shop equipped with NORCAN made to measure work stations. The use of closed and half-closed profiles resulted in structure without visible slots.



NORCAN production lines

Design and construction of the structure of an entire production line complete with its conveyors

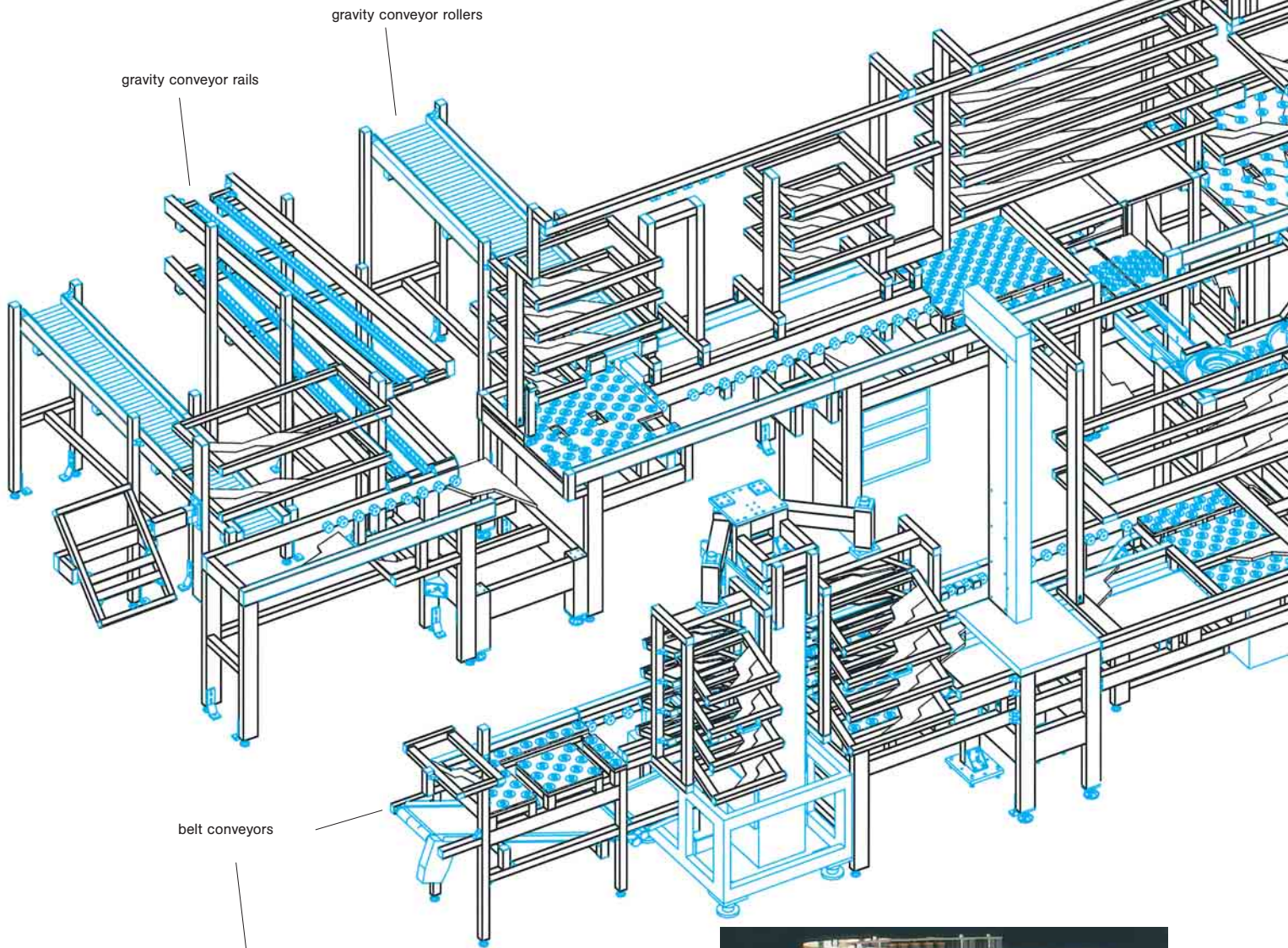

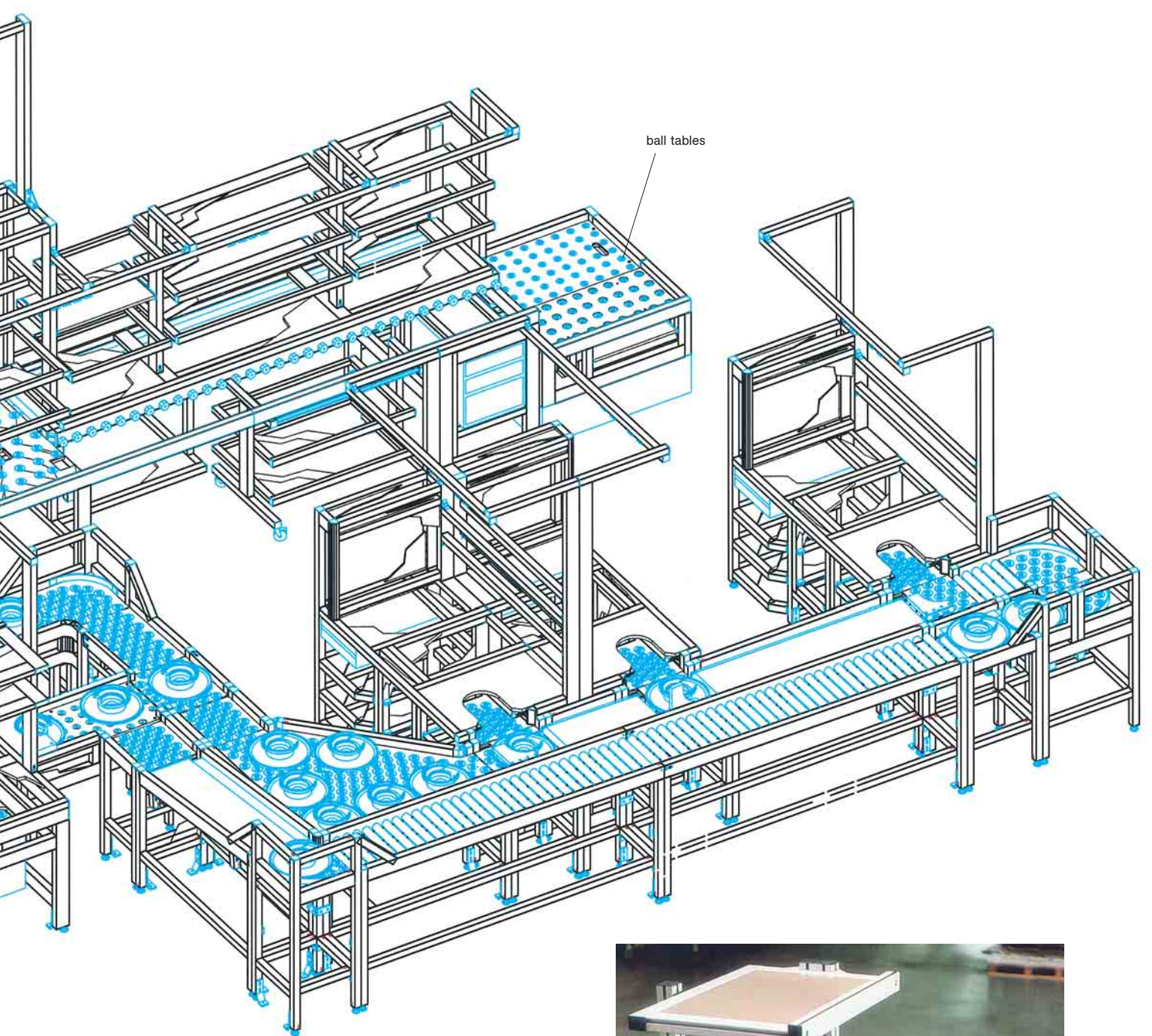

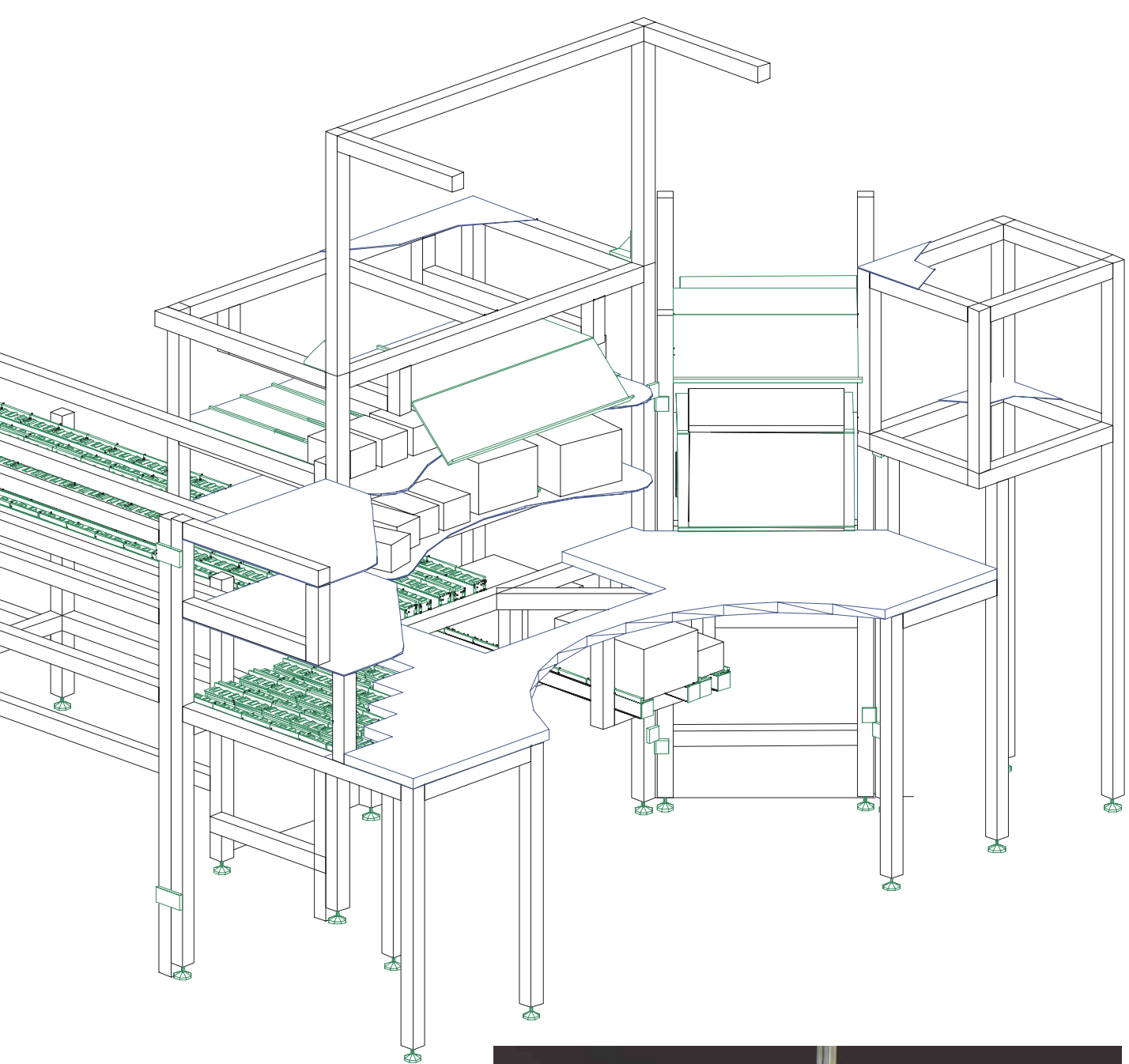

Live storage for workstations made from conveyor rails N0867, N0868 and guide rails N0804 (p.62/63) in several versions:

- horizontal storage (manual feeding)
- gravity storage (feeding by gravity via sloped rails)
- automatic storage (feeding with belt conveyors, roller conveyors etc.)



NORCAN application examples

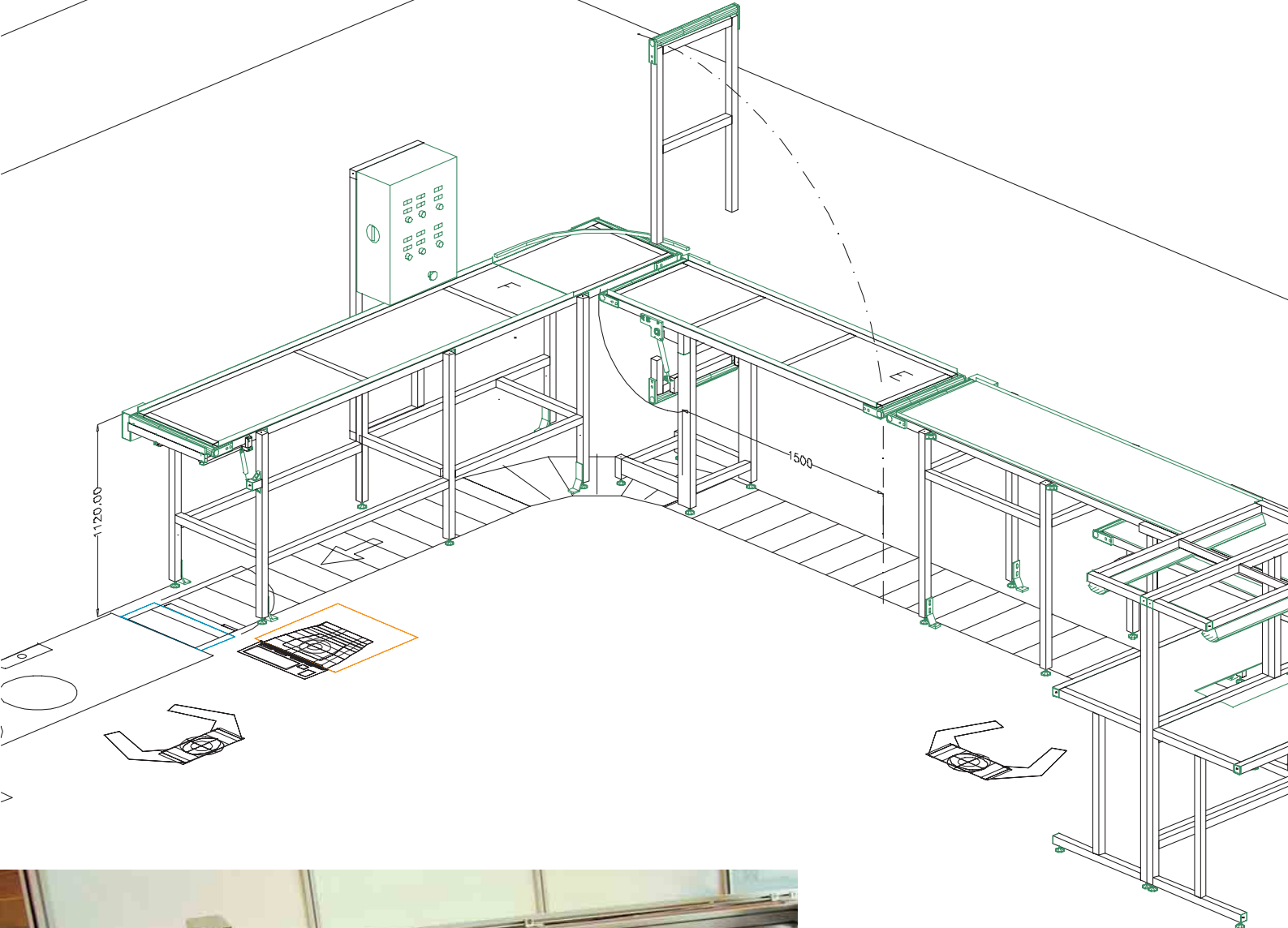

Machine frame with integrated guards, conveyors and an axis xy for very high accelerations.

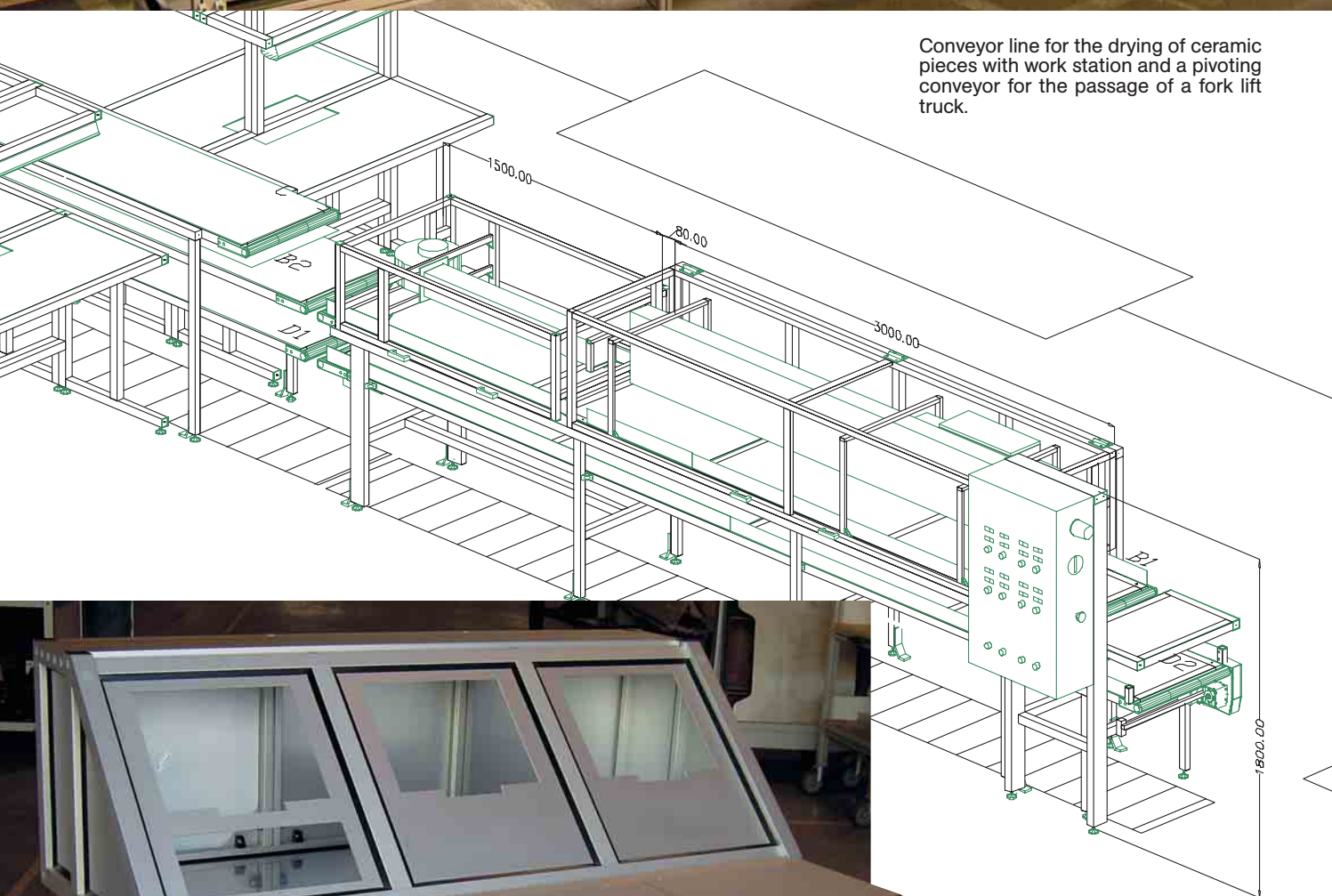

Conveyor line for the drying of ceramic pieces with work station and a pivoting conveyor for the passage of a fork lift truck.



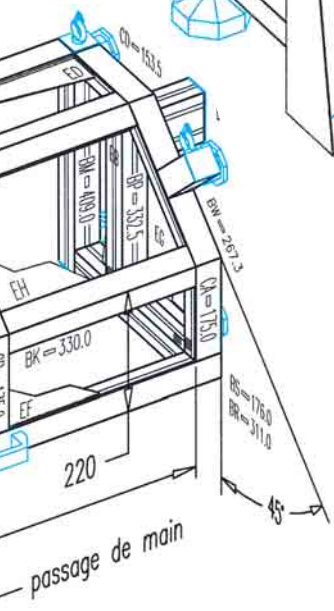
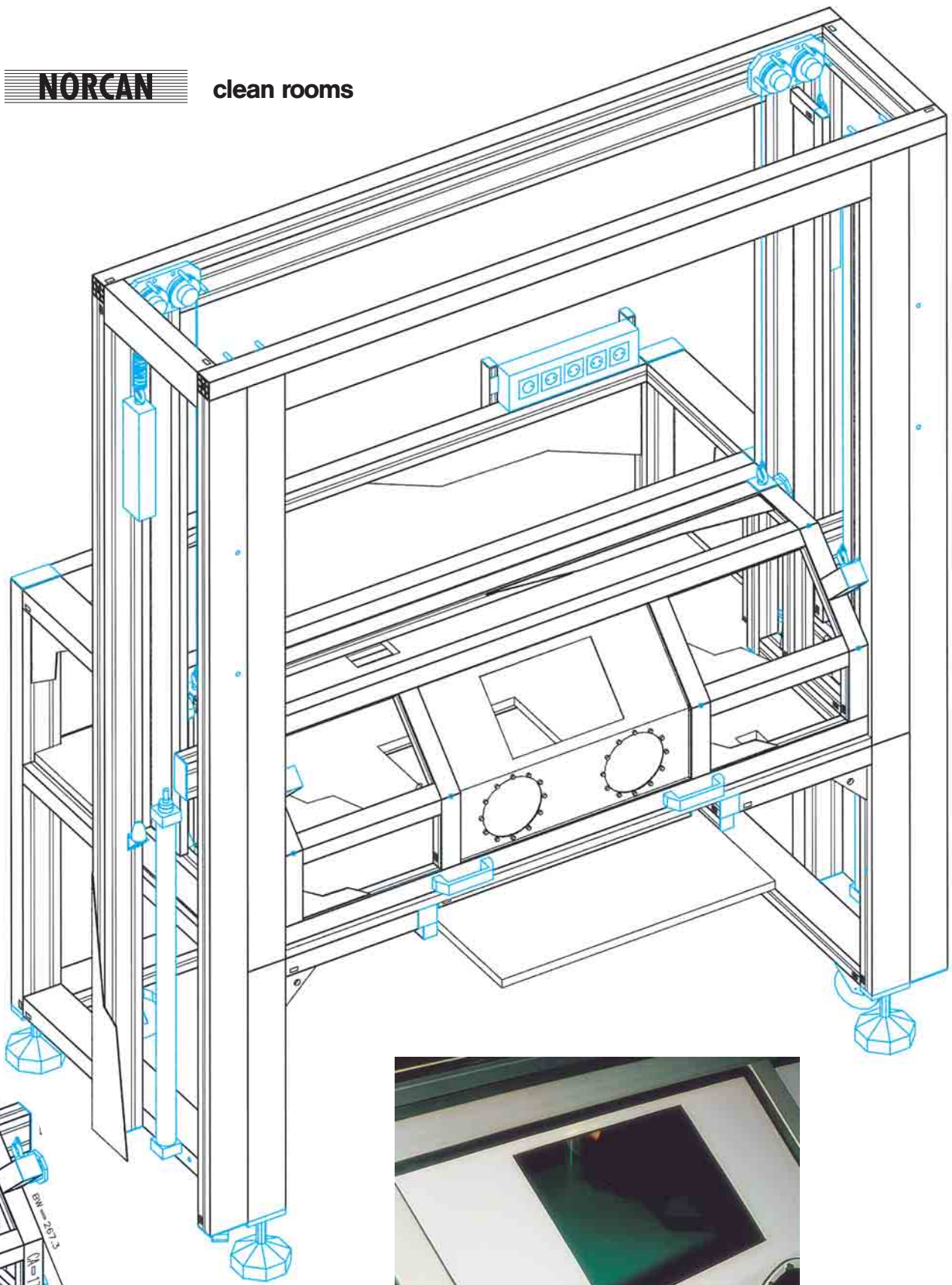

NORCAN application examples



Workstations built with housing profiles and semi-closed profiles.





Above : Two axis linear unit for manual NAP 57 linear guides and N 1301 roller wheels with wing nut stop system.



Opposite : gantry with vertical axis on smooth linear guide and locking handle. The horizontal axis runs on a NAP 57 linear guidance system.

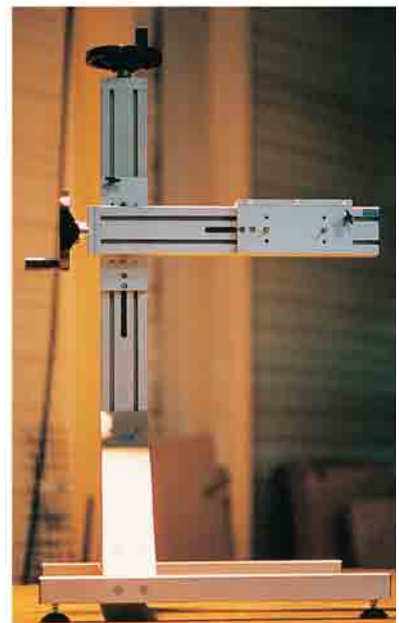

Above : small two axis system supported on linear guide blocks with trapezoidal screw drive.

Opposite : automatic transfer system comprising 4 belt conveyors and one roller conveyor with driven rollers.





NORCAN

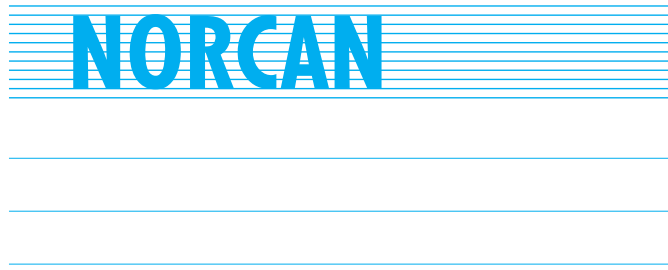

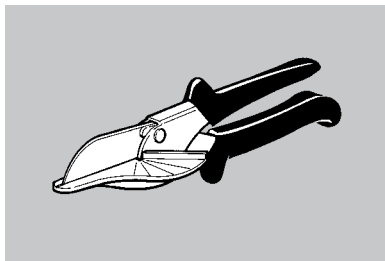
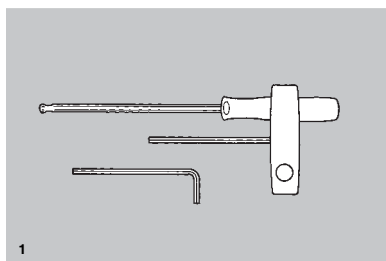

- 1. Tools:** Before starting, prepare a clean even surface and a set of keys NORCAN N 5210, (fig. 1):
- one key with handle for inserting the screws, rapid assembly and for fast tightening
 - one offset Allen key for better accessibility
 - one ball ended key.
 - a pair of scissors for strips N 5713

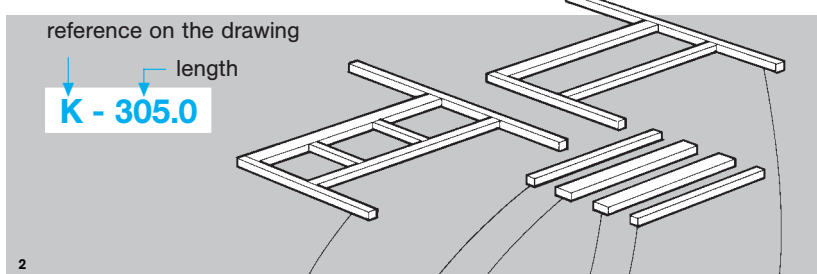

- 2. Study the drawing** to establish the sequence of assembly:
- identify the parts (see 3. below) and lay them out in groups.
 - Generally it's useful to assemble as many parts as possible on the same plane (fig. 3) before assembling the structure (fig. 4).
 - Check the sequence of assembly of the different parts to avoid omission of any part during assembly.

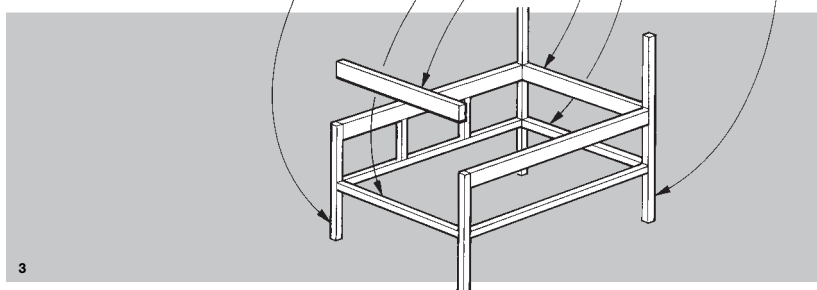

3. Every profile has a marking sticker which, too, defines its length and orientation (fig 2):

In fact, the marking sticker is located on the same place as it appears on the profile in the drawing:

- black (■) on the visible side (fig. 4, ①),
- outline (□) on the opposite side (fig. 4, ②).

If, on the drawing, the sticker is hidden by some part in front of it, the orientation of the part will be found by reference to its fixing holes.

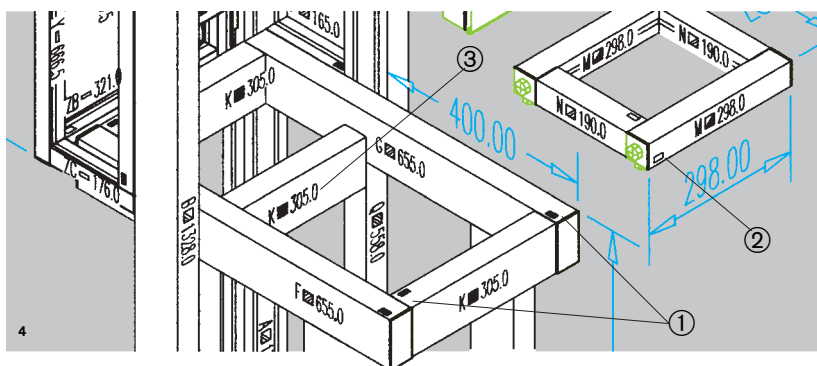

Thus it is quite easy to identify all parts and to lay them out in groups prior to assembly.

Before continuing, check again the sequence of assembly to avoid omitting any part during assembly.

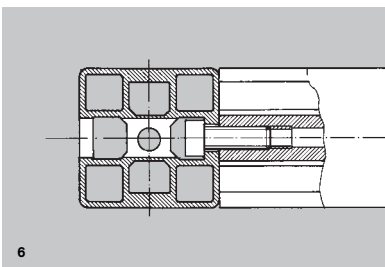
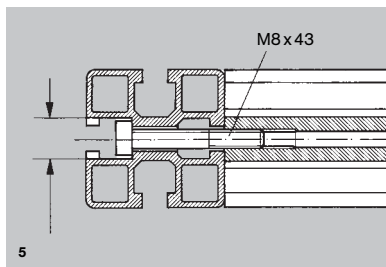

4. Choice of the screws :

M8 x 43: the bolt rests on the web of the profile (fig. 5).

M8 x 20: for deep countersinks passing through all webs of the profile (fig. 6).

Square washers: for profiles with slots only, to provide a better pressure distribution inside the slot (fig. 8), where it may be tilted and inserted.

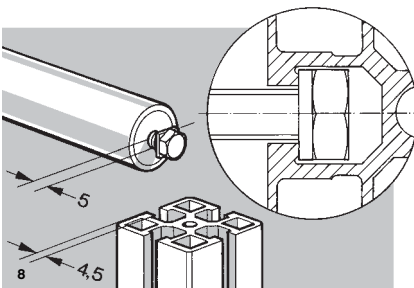
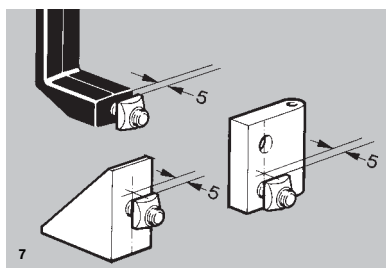

5. Assembly of parts onto slots : It may be useful to insert the screws, washers and nuts in the profiles and then to slide them into position along the slots. When doing so, provide a 5 mm clearance under the screw or the nut (fig. 7 and 8).

Anchor Feet	65	Handles	14, 15, 41
Angled Connectors	16, 31	Hinges	36...37
Antirootation Finger	26	Hydraulic lifts	67
Application Examples	89...111	Jigs	72
Assembly Tools	72	Latch, Ball	38, 40
Assembly Instructions	114	Linear Guides & Modules	48...63
Assembly, Nuts	26, 31	Loads and Deflections	73...76
Ball Latch	38, 40	Locks	40
Bases	64	Mesh welded	42
Bearings	48	Modules, Linear	58...61
Cable Conduct	68	Mounting Strip, panels	42
Cable Fixings	68	Panel Fixing, Panels	42...46
CAD Library	71	Paper, Isometric	70
CAD, N-CAD Utility	71	Pivots	32, 33
Castors	64	Plates and Panels	42
Connection adjustable	25...31	Plates, Assembly	30
Connectors angled	26, 31	Pneumatic Plates	69
Conveyors	88	Profile Alu, Handles	14, 15, 41
Corners	27...29	Profile Alu, Sliding Door	46
Cross Mounting Plate	30	Profile Aluminium	10...21
Cross Section 1 : 1	16...20	Profile Guides	52
Design, Advice	76...80	Profile Sealing Strip	66
Design, Isometric	70	Rails, Guide	51...61
Design, Sheet	70	Roller box	46, 47
Door Stop	38...39	Rollers for Linear Guides	48...63
Drawer Units	69	Roller Conveyors	63
Drills	72	Safety Switches	39
Electrical Continuity	23, 68, 78	Screws	22, 23
End Caps	66	Sealing Plugs	66
Fasteners (Max loads)	73...76	Sealing Strip, Doors	37
Fasteners	22...31	Sealing Strip, Profiles	66
Fixing Block, 5 Way	31	Security Screen	81
Fixing Block, Cables	50	Sliders	45...51
Fixing Block, Panels	42...44	Support, Sensor	35
Fixing Block, Tubes	35	Tap, Rolled	72
Foot Rest Support	34	Tools	72
Foot, Adjustable	64	Tube, Alu	15, 20, 35
Foot, Floor Fixing	65	Washers	23
Furniture, Workshop	82...87		
Guides, Linear, Carriages	48...63		

NORCAN is a registered Trademark. Most NORCAN profiles and some of their assembly methods are protected by patents, patent applications and/or registered designs. All rights of reproduction and translation are reserved. The photographs and designs of that catalogue are not of documentary value. Details are given as indications only and do not implicate our responsibility. In the areas of mechanical stress and safety we remind the constructor to verify his calculations and theories. Our design office can be consulted for questions beyond the scope of this document. Printed in France - OTT Imprimeur - 67310 Wasselonne - 053873